



**CHINO VALLEY**  
UNIFIED SCHOOL DISTRICT

Student Achievement • Safe Schools • Positive School Climate  
Humility • Civility • Service

# BOARD OF EDUCATION AGENDA

**June 28, 2018**

**BOARD OF EDUCATION**  
Pamela Feix, President  
James Na, Vice President  
Irene Hernandez-Blair, Clerk  
Andrew Cruz, Member  
Sylvia Orozco, Member



**SUPERINTENDENT**  
Wayne M. Joseph

**CHINO VALLEY UNIFIED SCHOOL DISTRICT**  
**REGULAR MEETING OF THE BOARD OF EDUCATION**  
**Chino Valley Unified School District**  
**5130 Riverside Drive, Chino, CA 91761 • Board Room**  
**5:20 p.m. – Closed Session • 7:00 p.m. – Regular Meeting**  
**June 28, 2018**

**AGENDA**

- The public is invited to address the Board of Education regarding items listed on the agenda. Comments on an agenda item will be accepted during consideration of that item, or prior to consideration of the item in the case of a closed session item. Persons wishing to address the Board are requested to complete and submit to the Administrative Secretary, Board of Education, a "Request to Speak" form available at the entrance to the Board room.
- In compliance with the Americans with Disabilities Act, please contact the Administrative Secretary, Board of Education, if you require modification or accommodation due to a disability.
- Agenda documents that have been distributed to members of the Board of Education less than 72 hours prior to the meeting are available for inspection at the Chino Valley Unified School District Administration Center, 5130 Riverside Drive, Chino, California, during the regular business hours of 7:30 a.m. to 4:30 p.m., Monday through Friday.
- Order of business is approximate and subject to change.

**I. OPENING BUSINESS**

**I.A. CALL TO ORDER – 5:20 P.M.**

1. Roll Call
2. Public Comment on Closed Session Items
3. Closed Session

**Discussion and possible action (times are approximate):**

- a. Conference with Legal Counsel Existing Litigation: Government Code 54954.4(c) and 54956.9 (d)(1): Federal District Court, Case No. EDCV 14-2336-JGB (DTBx) Freedom from Religion Foundation vs. Chino Valley Unified School District Board of Education. (Tyler & Bursch, LLP) (15 minutes)
- b. Conference with Legal Counsel Existing Litigation: Government Code 54954.5 (c) and 54956.9 (d)(1): Oxford Preparatory Academy v. Chino Valley Unified School District, et. al. SBC No. CIVDS1710045. (Chidester, Margaret A. & Associates) (15 minutes)
- c. Conference with Legal Counsel Anticipated Litigation: Government Code 54956.9 (d)(2) and (e)(1): One possible case. (Atkinson, Andelson, Loya, Ruud & Romo) (15 minutes)
- d. Student Expulsion Matter (Education Code 35146, 48918 (c) & (j)): Case 17/18-33. (10 minutes)
- e. Public Employee Appointment: Government Code 54957: Coordinator, Access, Equity & Assessment; Coordinator, Behavior Intervention; Coordinator, Technology; Principal, Buena Vista HS; Elementary and High School Assistant Principals. (15 minutes)
- f. Public Employee Discipline/Dismissal/Release: Government Code 54957: (15 minutes)

**I.B. RECONVENE TO REGULAR OPEN MEETING: 7:00 P.M.**

1. Report Closed Session Action
2. Pledge of Allegiance

**I.C. PRESENTATIONS**

1. James Moore, Superintendent, Alta Loma School District

**I.D. EMPLOYEE REPRESENTATIVES' COMMUNICATIONS**

I.E. COMMUNITY LIAISONS' COMMUNICATIONS

I.F. COMMENTS FROM THE AUDIENCE ON ITEMS NOT ON THE AGENDA

I.G. CHANGES AND DELETIONS

**II. ACTION**

II.A. ADMINISTRATION

II.A.1. Resolution 2017/2018-86 Order of Election and Specifications of the Election Order in the Chino Valley Unified School District of San Bernardino County, California; Resolution Ordering School District Election for Governing Board Members Whose Terms Expire December 7, 2018 Motion \_\_\_\_ Second \_\_\_\_  
 Page 8 Preferential Vote: \_\_\_\_  
 Vote: Yes \_\_\_\_ No \_\_\_\_

Recommend the Board of Education adopt Resolution 2017/2018-86 Order of Election and Specifications of the Election Order in the Chino Valley Unified School District of San Bernardino County, California; Resolution Ordering School District Election for Governing Board Members Whose Terms Expire December 7, 2018.

II.B. CURRICULUM, INSTRUCTION, INNOVATION, AND SUPPORT

II.B.1. 2018/2019 Local Control and Accountability Plan Motion \_\_\_\_ Second \_\_\_\_  
 Page 11 Preferential Vote: \_\_\_\_

Recommend the Board of Education adopt the 2018/2019 Local Control and Accountability Plan.

Vote: Yes \_\_\_\_ No \_\_\_\_

II.C. BUSINESS SERVICES

II.C.1. Adoption of the 2018/2019 Budget Motion \_\_\_\_ Second \_\_\_\_  
 Page 12 Preferential Vote: \_\_\_\_

Recommend the Board of Education adopt the 2018/2019 budget for all funds and authorize the Superintendent or designee to sign the 2018/2019 District Certification of Budget Adoption.

Vote: Yes \_\_\_\_ No \_\_\_\_

**II.D. HUMAN RESOURCES**

**II.D.1. Revisions to the Certificated and Classified Cabinet Salary Schedule**

Page 14

Recommend the Board of Education approve the revisions to the Certificated and Classified Cabinet Salary Schedule.

Motion \_\_\_\_ Second \_\_\_\_

Preferential Vote: \_\_\_\_

Vote: Yes \_\_\_\_ No \_\_\_\_

**II.D.2. Employment Contracts: Assistant Superintendent, Curriculum, Instruction, Innovation, and Support; Assistant Superintendent, Facilities, Planning and Operations; Associate Superintendent Business Services; and Associate Superintendent, Curriculum, Instruction, Innovation, and Support**

Page 16

Recommend the Board of Education approve the employment contracts:

- a) Assistant Superintendent, Curriculum, Instruction, Innovation, and Support;
- b) Assistant Superintendent, Facilities, Planning and Operations;
- c) Associate Superintendent, Business Services; and
- d) Associate Superintendent, Curriculum, Instruction, Innovation, and Support.

Motion \_\_\_\_ Second \_\_\_\_

Preferential Vote: \_\_\_\_

Vote: Yes \_\_\_\_ No \_\_\_\_

**III. CONSENT**

Motion \_\_\_\_ Second \_\_\_\_

Preferential Vote: \_\_\_\_

Vote: Yes \_\_\_\_ No \_\_\_\_

**III.A. ADMINISTRATION**

**III.A.1. Minutes of the June 14, 2018 Regular Meeting**

Page 38

Recommend the Board of Education approve the minutes of the June 14, 2018 regular meeting.

**III.B. BUSINESS SERVICES**

**III.B.1. Warrant Register**

Page 46

Recommend the Board of Education approve/ratify the warrant register, provided under separate cover.

**III.B.2. Fundraising Activities**

Page 47

Recommend the Board of Education approve/ratify the fundraising activities.

**III.B.3. Donations**

Page 51 Recommend the Board of Education accept the donations.

**III.B.4. 2018/2019 Applications to Operate Fundraising Activities and other Activities for the Benefit of Students**

Page 53 Recommend the Board of Education approve/ratify the 2018/2019 applications to operate fundraising activities and other activities for the benefit of students.

**III.B.5. Resolution 2017/2018-84 Use of 2018/2019 Education Protection Account Funds**

Page 55 Recommend the Board of Education adopt Resolution 2017/2018-84 Use of 2018/2019 Education Protection Accounts Funds.

**III.B.6. Resolution 2017/2018-85 Transfers of Appropriations for 2018/2019**

Page 59 Recommend the Board of Education adopt Resolution 2017/2018-85 Transfers of Appropriations for 2018/2019.

**III.C. CURRICULUM, INSTRUCTION, INNOVATION, AND SUPPORT**

**III.C.1. Student Expulsion Case 17/18-33**

Page 61 Recommend the Board of Education approve student expulsion case 17/18-33.

**III.C.2. School-Sponsored Trips**

Page 62 Recommend the Board of Education approve/ratify the following school-sponsored trips: Ayala HS; Chino HS; and Chino Hills HS.

**III.C.3. New Board Policy and Exhibit 5131.8 Students—Code of Conduct**

Page 64 Recommend the Board of Education approve the new Board Policy and Exhibit 5131.8 Students—Code of Conduct.

**III.C.4. Revision of Board Policy 6117 Instruction—Year-Round Schedules**

Page 75 Recommend the Board of Education approve the revision of Board Policy 6117 Instruction—Year-Round Schedules.

**III.D. FACILITIES, PLANNING, AND OPERATIONS**

**III.D.1. Purchase Order Register**

Page 80 Recommend the Board of Education approve/ratify the purchase order register, provided under separate cover.

**III.D.2. Agreements for Contractor/Consultant Services**

Page 81 Recommend the Board of Education approve/ratify the Agreements for Contractor/Consultant Services.

**III.D.3. Surplus/Obsolete Property**

Page 87

Recommend the Board of Education declare the District property surplus/obsolete and authorize staff to sell/dispose of said property.

**III.D.4. Bid 17-18-30F, Former El Rancho ES School Network**

Page 96

Recommend the Board of Education award Bid 17-18-30F, Former El Rancho ES School Network, to Federal Technology Solutions, Inc.

**III.D.5. Resolution 2017/2018-87 for Authorization to Utilize a Piggyback Contract**

Page 97

Recommend the Board of Education adopt Resolution 2017/2018-87 for authorization to utilize a piggyback contract.

**III.D.6. Change Orders for Phase 2 Project Design and Construction of Energy Efficiency Measures 1 and 2 at Various Sites**

Page 101

Recommend the Board of Education approve the change orders for Phase 2 Project Design and Construction of Energy Efficiency Measures 1 and 2 at Various Sites.

**III.D.7. Reimbursement Agreement for DSA Inspection Services Through T-Mobile**

Page 107

Recommend the Board of Education approve the Reimbursement Agreement for DSA Inspection Services through T-Mobile.

**III.E. HUMAN RESOURCES****III.E.1. Certificated/Classified Personnel Items**

Page 120

Recommend the Board of Education approve/ratify the certificated/classified personnel items.

**III.E.2. Rejection of Claims**

Page 129

Recommend the Board of Education reject the claims and refer them to the District's insurance adjuster.

**III.E.3. Revisions to the Job Descriptions for Assistant Superintendent, Business Services; Assistant Superintendent, Curriculum, Instruction, Innovation, and Support; Assistant Superintendent, Facilities, Planning and Operations; and Associate Superintendent, Educational Services**

Page 131

Recommend the Board of Education approve the revisions to the job descriptions for:

- a) Assistant Superintendent, Business Services;
- b) Assistant Superintendent, Curriculum, Instruction, Innovation, and Support;
- c) Assistant Superintendent, Facilities, Planning and Operations; and
- d) Associate Superintendent, Educational Services.

**IV. INFORMATION**

**IV.A. BUSINESS SERVICES**

**IV.A.1. Revision of Board Policy and Administrative Regulation 3100 Business and Noninstructional Operations—Budget**

Page 154

Recommend the Board of Education receive for information the revision of Board Policy and Administrative Regulation 3100 Business and Noninstructional Operations—Budget.

**IV.B. CURRICULUM, INSTRUCTION, INNOVATION, AND SUPPORT**

**IV.B.1. Revision of Board Policy 5127 Students—Graduation Ceremonies and Activities**

Page 169

Recommend the Board of Education receive for information the revision of Board Policy 5127 Students—Graduation Ceremonies and Activities.

**IV.B.2. Revision of Administrative Regulation 6146.11 Instruction—Alternative Credits Toward Graduation**

Page 174

Recommend the Board of Education receive for information the revision of Administrative Regulation 6146.11 Instruction—Alternative Credits Toward Graduation.

**V. COMMUNICATIONS**

**BOARD MEMBERS AND SUPERINTENDENT**

**VI. ADJOURNMENT**

Prepared by: Patricia Kaylor, Administrative Secretary, Board of Education  
Date posted: June 22, 2018

**CHINO VALLEY UNIFIED SCHOOL DISTRICT**

**Our Motto:**

Student Achievement • Safe Schools • Positive School Climate  
Humility • Civility • Service

**DATE:** June 28, 2018

**TO:** Members, Board of Education

**FROM:** Wayne M. Joseph, Superintendent

**SUBJECT: RESOLUTION 2017/2018-86 ORDER OF ELECTION AND SPECIFICATIONS OF THE ELECTION ORDER IN THE CHINO VALLEY UNIFIED SCHOOL DISTRICT OF SAN BERNARDINO COUNTY, CALIFORNIA; RESOLUTION ORDERING SCHOOL DISTRICT ELECTION FOR GOVERNING BOARD MEMBERS WHOSE TERMS EXPIRE DECEMBER 7, 2018**

=====

**BACKGROUND**

The Office of the County Superintendent of Schools notified the District on June 14, 2018, that the Biennial election of School Trustees is required to be held on Tuesday, November 6, 2018. It will be a consolidated election to include governing board members in elementary, high school, unified, and community college districts.

The attached Order of Election and Specification of the Election Order must be adopted by the Governing Board, signed by the clerk or secretary of the Board, and returned to the Registrar of Voters office no later than July 6, 2018.

Effective July 16, 2018, candidates may obtain their Declaration of Candidacy from the Registrar of Voters office, 777 E. Rialto Avenue, San Bernardino, California. The last day to file said Declaration of Candidacy in the office of the Registrar of Voters is 5:00 p.m., August 10, 2018.

If an incumbent has not filed a Declaration of Candidacy by 5:00 p.m. on the 88<sup>th</sup> day (August 10) before the election, the nomination period shall extend to 5:00 p.m. on the 83<sup>rd</sup> day (August 15) before the election for other than the incumbent.

The Governing Board has the responsibility of publishing a legal notice regarding the procedure of appointing a governing board member when no candidate or an insufficient number of candidates have filed for the office.

Approval of this item supports the goals identified within the District's Strategic Plan.



## **RECOMMENDATION**

It is recommended the Board of Education adopt Resolution 2017/2018-86 Order of Election and Specifications of the Election Order in the Chino Valley Unified School District of San Bernardino County, California; Resolution Ordering School District Election for Governing Board Members Whose Terms Expire December 7, 2018.

## **FISCAL IMPACT**

The cost of the election will be prorated among the school districts and other agencies consolidating with the election. The District will be billed after the election.

WMJ:pk

**ORDER OF ELECTION  
and  
SPECIFICATIONS OF THE ELECTION ORDER**

**CHINO VALLEY UNIFIED SCHOOL DISTRICT OF  
SAN BERNARDINO COUNTY, CALIFORNIA**

**RESOLUTION 2017/2018-86 ORDERING SCHOOL DISTRICT ELECTION FOR  
GOVERNING BOARD MEMBER'S WHOSE TERMS EXPIRE DECEMBER 7, 2018**

Resolved that, pursuant to Education Code, Section 5302, the County Superintendent of Schools of this County is hereby ORDERED to call an election for the purpose and in accordance with designations contained in the following specifications of the Election Order made under the authority of Education Code Sections 5304, 5320, and 5322.

**SPECIFICATIONS OF THE ELECTION ORDER**

Date of Election: Tuesday, November 6, 2018

Purpose: Election of Two Governing Board Members

Polls will open at 7:00 a.m. and close at 8:00 p.m.

I, Wayne M. Joseph, Secretary of the Governing Board of the Chino Valley Unified School District, San Bernardino County California, do hereby certify that the foregoing is a full, true and correct copy of a resolution adopted by the said Board at a regular meeting thereof held at its regular place of meeting on June 28, 2018.

Dated: \_\_\_\_\_

\_\_\_\_\_  
Wayne M. Joseph, Secretary

Submit one (1) copy to the San Bernardino County Elections office  
Submit one (1) copy to the County Superintendent of Schools  
One (1) copy for your files

**CHINO VALLEY UNIFIED SCHOOL DISTRICT**

**Our Motto:**

Student Achievement • Safe Schools • Positive School Climate  
Humility • Civility • Service

**DATE:** June 28, 2018  
**TO:** Members, Board of Education  
**FROM:** Wayne M. Joseph, Superintendent  
**SUBJECT: 2018/2019 LOCAL CONTROL AND ACCOUNTABILITY PLAN**

=====

**BACKGROUND**

The Local Control Funding Formula (LCFF) system requires that each Local Educational Agency (LEA) develop, adopt and annually update a three-year Local Control and Accountability Plan (LCAP). The LCAP is required to identify goals and measure progress for student subgroups (English learners, low income, and foster youths) across multiple performance indicators.

Pursuant to Education Codes 52060 and 52066, the LCAP describes the District's overall vision for students, annual goals, and specific actions the District will take to achieve its identified vision and goals. Additionally, the LCAP must focus on eight areas identified as state priorities. The plan also demonstrates how the District's budget will help achieve the goals, and assess each year how well the strategies in the plan were able to improve outcomes. As such, the District is required to annually update its three-year LCAP, as necessary.

The Board conducted a public hearing on this item at its June 14, 2018 meeting. Subsequently, the District is required to submit its LCAP to the San Bernardino County Superintendent of Schools. The approved LCAP becomes effective July 1, 2018. A hardcopy of the draft 2018/2019 LCAP is available in the lobby for public inspection.

Approval of this item supports the goals identified within the District's Strategic Plan.

**RECOMMENDATION**

It is recommended the Board of Education adopt the 2018/2019 Local Control and Accountability Plan.

**FISCAL IMPACT**

\$40,599,477.00 from General and Restricted Funds.

WMJ:rtr

**CHINO VALLEY UNIFIED SCHOOL DISTRICT**

**Our Motto:**

Student Achievement • School Safety • Positive School Climate  
Humility • Civility • Service

**DATE:** June 28, 2018

**TO:** Members, Board of Education

**FROM:** Wayne M. Joseph, Superintendent

**PREPARED BY:** Sandra H. Chen, Assistant Superintendent, Business Services  
Liz Pensick, Director, Fiscal Services

**SUBJECT: ADOPTION OF THE 2018/2019 BUDGET**

=====

**BACKGROUND**

In July 2013, Governor Jerry Brown enacted a budget that included a brand-new education funding system called the Local Control Funding Formula (LCFF). The LCFF distributed combined resources to school districts through a base grant per unit of average daily attendance with additional supplemental funding allocated to districts based on their proportion of English learners, foster youth, and free and reduced-price meal eligible students. The State's estimated timeframe to fully transition to the new funding formula was 2020/2021.

The May Revision is the final statutory opportunity for the Governor to update his economic projections prior to enactment of the State Budget in June. On May 11, 2018, Governor Brown released the May Revision to his January budget proposal for the 2018/2019 fiscal year. Throughout the current fiscal year, state revenues have outpaced forecasts both before and during the important tax month of April. With this solid revenue base, Governor Brown is proposing to fully fund the LCFF in 2018/2019, two years earlier than originally planned. He also proposed one-time discretionary funds to offset against the outstanding mandate claims.

In his press conference, while acknowledging the increased revenues and the economy's overall strong fiscal health, Governor Brown returned to his theme of fiscal prudence. The May Revision reflects his belief in fiscal restraint and his fear that an economic downturn is inevitable. Governor Brown noted that it is the role of government to manage and keep an even keel on spending between good times and bad by building the State's reserves and avoid substantial new ongoing obligations. Districts are advised to remain focused on stabilizing expenditures, maintaining adequate reserves, and planning to sustain current programs.

The District's proposed budget for 2018/2019 reflects the Governor's proposed LCFF funding structures included in his May Revision, using the LCFF calculators provided by School Services of California and the San Bernardino County Superintendent of Schools. The proposed budget for 2018/2019 also reflects the actions and services included in the proposed Local Control and Accountability Plan.

Based on the current revenue assumptions and current expenditure plan, the proposed general fund budget for 2018/2019 and two subsequent years will meet the minimum statutory reserve requirement. All other funds are also in balance.

Education Code 52062 requires the Board of Education to conduct a public hearing prior to approving the 2018/2019 budget at its June 28, 2018 meeting. A public hearing was conducted on June 14, 2018. The 2018/2019 budget is being presented under separate cover. A hard copy is available for public inspection in the District lobby of the Chino Valley Unified School District.

### **RECOMMENDATION**

It is recommended the Board of Education adopt the 2018/2019 budget for all funds and authorize the Superintendent or designee to sign the 2018/2019 District Certification of Budget Adoption.

WMJ:SHC:LP:wc

**CHINO VALLEY UNIFIED SCHOOL DISTRICT**

**Our Motto:**

Student Achievement • Safe Schools • Positive School Climate  
Humility • Civility • Service

**DATE:** June 28, 2018  
**TO:** Members, Board of Education  
**FROM:** Wayne M. Joseph, Superintendent  
**PREPARED BY:** Lea Fellows, Assistant Superintendent, Human Resources  
**SUBJECT: REVISIONS TO THE CERTIFICATED AND CLASSIFIED CABINET SALARY SCHEDULE**

=====

**BACKGROUND**

Board Policy 4151, personnel, employee compensation, states in part, “the board shall adopt separate salary schedules for certificated, classified, confidential and supervisory and administrative personnel” further, “salary schedules for staff who are not part of a bargaining unit shall be determined by the board at the recommendation of the superintendent or designee.”

As such, the Board is being asked to approve the revisions to the Certificated and Classified Cabinet Salary Schedule effective July 1, 2018, to include the classifications of Associate Superintendent of Business Services; and Curriculum, Instruction, Innovation, and Support. The proposed revisions are provided in UPPER CASE, while old language to be deleted is ~~lined through~~.

Approval of this item supports the goals identified within the District’s Strategic Plan.

**RECOMMENDATION**

It is recommended the Board of Education approve the revisions to the Certificated and Classified Cabinet Salary Schedule.

**FISCAL IMPACT**

None.

WMJ:LF:mcm

**CHINO VALLEY UNIFIED SCHOOL DISTRICT**  
**Certificated and Classified Cabinet Salary Schedule**  
**2018/2019**  
**Includes 2% Increase Board Approved 2/1/18**  
**EFFECTIVE JULY 1, 2018**

RANGE	POSITION	DAYS	STEP 1	STEP 2	STEP 3	STEP 4
9	ASSOCIATE SUPERINTENDENT BUSINESS SERVICES CURRICULUM, INSTRUCTION, INNOVATION & SUPPORT	226	178,556	185,698	193,126	200,851
12	<del>Asst. Supt</del> ASSISTANT SUPERINTENDENT Facilities and Planning <del>Business Services</del> Curriculum, Instruction, Innovation & Support Human Resources	226	152,632	158,736	165,087	171,688

<b>Longevity Certificated Management</b>	
15 Years of Service	\$1,603
20 Years of Service	\$3,207
25 Years of Service	\$4,812
30 Years of Service	\$6,417

**CHINO VALLEY UNIFIED SCHOOL DISTRICT**

**Our Motto:**

Student Achievement • Safe Schools • Positive School Climate  
Humility • Civility • Service

**DATE:** June 28, 2018  
**TO:** Members, Board of Education  
**FROM:** Wayne M. Joseph, Superintendent  
**PREPARED BY:** Lea Fellows, Assistant Superintendent, Human Resources  
Suzanne Hernandez, Ed.D., Director, Human Resources  
Richard Rideout, Director, Human Resources  
**SUBJECT: EMPLOYMENT CONTRACTS: ASSISTANT SUPERINTENDENT, CURRICULUM, INSTRUCTION, INNOVATION, AND SUPPORT; ASSISTANT SUPERINTENDENT, FACILITIES, PLANNING AND OPERATIONS; ASSOCIATE SUPERINTENDENT BUSINESS SERVICES; AND ASSOCIATE SUPERINTENDENT, CURRICULUM, INSTRUCTION, INNOVATION, AND SUPPORT**

=====

**BACKGROUND**

Government Code 53262 requires that “all contracts with a superintendent, deputy superintendent, assistant superintendent, associate superintendent...of a local agency shall be ratified in an open session of the governing body which shall be reflected in the governing body’s minutes.”

The restructuring and reorganization of key positions are needed to meet the strategic goals and vision of the Chino Valley Unified School District Board of Education. On July 1, 2018, the Deputy Superintendent position will become vacant and the position will not be filled. In order to better meet the needs of the District in its efforts to successfully implement the District goals (i.e. Measure G, Local Control Accountability Plan), two (2) associate superintendent positions in the Divisions of Business Services and Curriculum, Instruction, Innovation, and Support are being proposed.

Approval of this item supports the goals identified within the District’s Strategic Plan.

**RECOMMENDATION**

It is recommended the Board of Education approve the employment contracts:

- a) Assistant Superintendent, Curriculum, Instruction, Innovation, and Support;
- b) Assistant Superintendent, Facilities, Planning and Operations;
- c) Associate Superintendent, Business Services; and
- d) Associate Superintendent, Curriculum, Instruction, Innovation, and Support.



**FISCAL IMPACT**

\$14,179.00 cost savings to the General Fund for the Associate Superintendents. No impact for the Assistant Superintendents.

WMJ:LF:SH:RR:mcm

**CONTRACT FOR EMPLOYMENT OF ASSOCIATE SUPERINTENDENT**

**between the**

**BOARD OF EDUCATION**

**of the**

**CHINO VALLEY UNIFIED SCHOOL DISTRICT**

**County of San Bernardino, California**

**and**

**Sandra H. Chen**

**1. OFFER**

This contract is entered into this 28<sup>th</sup> day of June 2018, by the Board of Education of the Chino Valley Unified School District (“District”) and Sandra H. Chen. The District hereby employs Sandra H. Chen as Associate Superintendent, Business Services (“Associate Superintendent”) for a term beginning July 1, 2018, and ending June 30, 2022. This contract may be extended annually, subject to the terms and conditions hereinafter set forth below, and subject to the Associate Superintendent receiving a satisfactory job performance evaluation on or before March 1<sup>st</sup> of each calendar year by the Superintendent.

**2. SALARY**

The Associate Superintendent shall be afforded the same opportunity to STEP on the salary schedule as all other employees of the District. The salary of the Associate Superintendent shall be Range 9 STEP 1, one hundred seventy-eight thousand, five hundred fifty-six dollars (\$178,556.00), payable in twelve (12) equal payments. The Associate Superintendent shall receive an annual salary increase that is not less than the percentage increase granted to the other management employees of the District.

**3. CHIEF BUSINESS OFFICER CERTIFICATE STIPEND**

The Associate Superintendent shall be entitled to an annual stipend of four (4%) percent of her annual salary for a Chief Business Officer Certificate which is payable in twelve (12) equal payments.

**4. LONGEVITY**

The Associate Superintendent shall be afforded the same opportunity to participate in the District's longevity program as all other management employees, which is payable in twelve (12) equal payments.

**5. FRINGE BENEFITS**

The Associate Superintendent shall be afforded the same opportunity to participate in the District's benefit program as all other management employees. The Associate Superintendent shall receive three hundred fifty dollars (\$350.00) a month to defray her costs of using her personal vehicle for District business.

**6. ORGANIZATIONAL MEMBERSHIP**

The District shall pay full dues for the Associate Superintendent's membership in the Association of California School Administrators (ACSA) or one other as deemed appropriate by the Associate Superintendent.

**7. SALARY CHANGE**

The Board of Education reserves the right to modify the annual salary rate of the Associate Superintendent's contract, provided that the salary shall not be decreased without the Associate Superintendent's consent.

**8. VACATIONS AND SICK LEAVE**

The Associate Superintendent shall be required to render twelve (12) months of full and regular service to the District during each annual period covered by this agreement, except that the Associate Superintendent shall be entitled to twenty-two (22) days vacation according to District policy. The Associate Superintendent is

entitled to cash out up to thirty (30) days of unused vacation annually. In the event of termination of employment, the Associate Superintendent shall be entitled to compensation for unused vacation at the salary range effective during the school year in which the vacation credit was earned, not to exceed 56 days. The Associate Superintendent will be entitled to twenty-two (22) days of earned sick leave per year.

**9. CONDITIONS**

This contract is subject to all applicable laws of the State of California and to the lawful rules and regulations of the California State Board of Education and the Board of Education of the District. Said laws, rules, and regulations are hereby made a part of the terms and conditions of this contract, as though herein set forth.

**10. RENEWAL**

This contract may be terminated by the Board provided that written notice be given to the Associate Superintendent no later than March 15<sup>th</sup> of the final year of the contract.

**11. TERMINATION FOR CAUSE**

The District may terminate this contract at any time for cause, pursuant to the California Education Code. In the event of termination for cause, the District shall have no obligation to pay remaining salary or benefits, except for that salary or benefits accrued by the Associate Superintendent through the effective date of said termination.

**12. EARLY TERMINATION BY ASSOCIATE SUPERINTENDENT**

The Associate Superintendent may terminate her obligations under this contract by giving the District at least thirty (30) days written notice in advance of said termination in which case she shall receive her salary and benefits during said period unless the parties mutually agree in writing to other provisions.

**13. EVALUATION**

The Associate Superintendent shall report to, and be directly responsible to the Superintendent. The Superintendent shall evaluate and assess in writing the performance of the Associate Superintendent at least once a year during the term of this agreement. Said evaluation and assessment shall be reasonably related to the job description of the Associate Superintendent and the goals and objectives of the District.

**14. STATEMENT REQUIRED BY GOVERNMENT CODE SECTION 53260**

Regardless of the term of this Contract, if this Contract is terminated, the maximum cash settlement that the Associate Superintendent may receive shall be in an amount equivalent to her monthly salary multiplied by the number of months left on the unexpired term of the Contract, not to exceed eighteen (18) months.

**15. STATEMENT REQUIRED BY GOVERNMENT CODE SECTION 53243.2**

If this Contract is terminated, any cash settlement related to the termination shall be fully reimbursed to the District if the Associate Superintendent is convicted of a crime involving an abuse of her office or position.

**16. ACTION AT OPEN SESSION OF REGULAR MEETING**

Pursuant to Government Code sections 54956(b) and 54957.6(a), this Contract shall be approved in an open session of a regular meeting of the Board of Education.

**17. SAVINGS CLAUSE**

If any provisions of this Contract are held to be contrary to law by final legislative act or a court of competent jurisdiction inclusive of appeals, if any, such provisions shall not be deemed valid and subsisting except to the extent permitted by law, but all other provisions shall continue in full force and effect.

**18. COMPLETE AGREEMENT**

This Contract is the full and complete agreement between the parties hereto. Any amendment, modifications, or variations from the terms of this Contract shall be in

writing and shall be effective only upon approval of such amendment, modification, or variation by the Board and the Associate Superintendent.

IN WITNESS WHEREOF THE PARTIES HERETO HAVE EXECUTED THIS CONTRACT ON THE DATE INDICATED, UPON ACTION OF THE BOARD OF EDUCATION OF THE CHINO VALLEY UNIFIED SCHOOL DISTRICT.

**SIGNATURES OF THE BOARD OF EDUCATION OF THE CHINO VALLEY UNIFIED SCHOOL DISTRICT,**

**County of San Bernardino, California**

\_\_\_\_\_  
Pamela Feix, President

\_\_\_\_\_  
Date

\_\_\_\_\_  
James Na, Vice President

\_\_\_\_\_  
Date

\_\_\_\_\_  
Irene Hernandez-Blair, Clerk

\_\_\_\_\_  
Date

\_\_\_\_\_  
Sylvia Orozco, Member

\_\_\_\_\_  
Date

\_\_\_\_\_  
Andrew Cruz, Member

\_\_\_\_\_  
Date

**SIGNATURE OF THE ASSOCIATE SUPERINTENDENT,  
BUSINESS SERVICES**

\_\_\_\_\_  
Sandra H. Chen

\_\_\_\_\_  
Date

**CONTRACT FOR EMPLOYMENT OF ASSISTANT SUPERINTENDENT**

**between the**

**BOARD OF EDUCATION**

**of the**

**CHINO VALLEY UNIFIED SCHOOL DISTRICT**

**County of San Bernardino, California**

**and**

**Lea Fellows**

**1. OFFER**

This contract is entered into this 28<sup>th</sup> day of June 2018, by the Board of Education of the Chino Valley Unified School District (“District”) and Lea Fellows. The District hereby employs Lea Fellows as Assistant Superintendent, Curriculum, Instruction, Innovation and Support (“Assistant Superintendent”) for a term beginning July 1, 2018, and ending June 30, 2022. This contract may be extended annually, subject to the terms and conditions hereinafter set forth below, and subject to the Assistant Superintendent receiving a satisfactory job performance evaluation on or before March 1<sup>st</sup> of each calendar year by the Superintendent or designee.

**2. SALARY**

The Assistant Superintendent shall be afforded the same opportunity to STEP on the salary schedule as all other employees of the District. The annual salary of the Assistant Superintendent shall be Range 12 STEP 3, one hundred sixty-five thousand, eighty seven dollars (\$165,087.00), payable in twelve (12) equal payments. The Assistant Superintendent shall receive an annual salary increase that is not less than the percentage increase granted to the other management employees of the District.

**3. LONGEVITY**

The Assistant Superintendent shall be afforded the same opportunity to participate in the District's longevity program as all other management employees, which is payable in twelve (12) equal payments.

**4. FRINGE BENEFITS**

The Assistant Superintendent shall be afforded the same opportunity to participate in the District's benefit program as all other management employees. The Assistant Superintendent shall receive three hundred fifty dollars (\$350.00) a month to defray her cost of using her personal vehicle for District business.

**5. ORGANIZATIONAL MEMBERSHIP**

The District shall pay full dues for the Assistant Superintendent's membership in the Association of California School Administrators (ACSA) or one other as deemed appropriate by the Assistant Superintendent.

**6. SALARY CHANGE**

The Board of Education reserves the right to modify the annual salary rate of the Assistant Superintendent's contract, provided that the salary shall not be decreased without the Assistant Superintendent's consent.

**7. VACATIONS AND SICK LEAVE**

The Assistant Superintendent shall be required to render twelve (12) months of full and regular service to the District during each annual period covered by this agreement, except that the Assistant Superintendent shall be entitled to twenty-two (22) vacation days according to District policy. The Assistant Superintendent is entitled to cash out up to thirty (30) days of unused vacation annually. In the event of termination of employment, the Assistant Superintendent shall be entitled to compensation for unused vacation at the salary range effective during the school year in which the vacation credit was earned, not to exceed 56 days. The Assistant Superintendent will be entitled to twenty-two (22) days of earned sick leave per year.



**8. CONDITIONS**

This contract is subject to all applicable laws of the State of California and to the lawful rules and regulations of the California State Board of Education and the Board of Education of the District. Said laws, rules, and regulations are hereby made a part of the terms and conditions of this contract, as though herein set forth.

**9. RENEWAL**

This contract may be terminated by the Board provided that written notice be given to the Assistant Superintendent no later than March 15<sup>th</sup> of the final year of the contract.

**10. TERMINATION FOR CAUSE**

The District may terminate this contract at any time for cause, pursuant to the California Education Code. In the event of termination for cause, the District shall have no obligation to pay remaining salary or benefits, except for that salary or benefits accrued by the Assistant Superintendent through the effective date of said termination.

**11. EARLY TERMINATION BY ASSISTANT SUPERINTENDENT**

The Assistant Superintendent may terminate his obligation under this contract by giving the District at least thirty (30) days written notice in advance of said termination in which case he shall receive his salary and benefits during said period unless the parties mutually agree in writing to other provisions.

**12. EVALUATION**

The Assistant Superintendent shall report to, and be directly responsible to the Superintendent or designee. The Superintendent or designee shall evaluate and assess in writing the performance of the Assistant Superintendent at least once a year during the term of this agreement. Said evaluation and assessment shall be reasonably related to the job description of the Assistant Superintendent and the goals and objectives of the District.

**13. STATEMENT REQUIRED BY GOVERNMENT CODE SECTION 53260**

Regardless of the term of this Contract, if this Contract is terminated, the maximum cash settlement that the Assistant Superintendent may receive shall be in an amount equivalent to her monthly salary multiplied by the number of months left on the unexpired term of the Contract, not to exceed eighteen (18) months.

**14. STATEMENT REQUIRED BY GOVERNMENT CODE SECTION 53243.2**

If this contract is terminated any cash settlement related to the termination shall be fully reimbursed to the District if the Assistant Superintendent is convicted of a crime involving an abuse of her office or position.

**15. ACTION AT OPEN SESSION OF REGULAR MEETING**

Pursuant to Government Code sections 54956(b) and 54957.6(a), this contract shall be approved in an open session of a regular meeting of the Board of Education.

**16. SAVING CLAUSE**

If any provisions of this Contract are held to be contrary to law by final legislative act or a court of competent jurisdiction inclusive of appeals, if any, such provisions shall not be deemed valid and subsisting except to the extent permitted by law, but all other provisions shall continue in full force and effect.

**17. COMPLETE AGREEMENT**

The Contract is the full and complete agreement between the parties hereto. Any amendment, modifications, or variations from the terms of this Contract shall be in writing and shall be effective only upon approval of such amendment, modification, or variation by the Board and the Assistant Superintendent.

IN WITNESS WHEREOF THE PARTIES HERETO HAVE EXECUTED THEIR CONTRACT ON THE DATE INDICATED, UPON ACTION OF THE BOARD OF EDUCATION OF THE CHINO VALLEY UNIFIED SCHOOL DISTRICT.

**SIGNATURES OF THE BOARD OF EDUCATION OF THE CHINO VALLEY UNIFIED SCHOOL DISTRICT,**

**County of San Bernardino, California**

\_\_\_\_\_  
Pamela Feix, President Date

\_\_\_\_\_  
James Na, Vice President Date

\_\_\_\_\_  
Irene Hernandez-Blair, Clerk Date

\_\_\_\_\_  
Andrew Cruz, Member Date

\_\_\_\_\_  
Sylvia Orozco, Member Date

**SIGNATURE OF THE ASSISTANT SUPERINTENDENT, CURRICULUM, INSTRUCTION, INNOVATION AND SUPPORT**

\_\_\_\_\_  
Lea Fellows Date

**CONTRACT FOR EMPLOYMENT OF ASSOCIATE SUPERINTENDENT**

**between the**

**BOARD OF EDUCATION**

**of the**

**CHINO VALLEY UNIFIED SCHOOL DISTRICT**

**County of San Bernardino, California**

**and**

**Grace Park, Ed.D.**

**1. OFFER**

This contract is entered into this 28<sup>th</sup> day of June 2018, by the Board of Education of the Chino Valley Unified School District (“District”) and Grace Park, Ed.D. The District hereby employs Grace Park, Ed.D. as Associate Superintendent, Curriculum, Instruction, Innovation, and Support (“Associate Superintendent”) for a term beginning July 1, 2018, and ending June 30, 2022. This contract may be extended annually, subject to the terms and conditions hereinafter set forth below, and subject to the Associate Superintendent receiving a satisfactory job performance evaluation on or before March 1<sup>st</sup> of each calendar year by the Superintendent.

**2. SALARY**

The Associate Superintendent shall be afforded the same opportunity to STEP on the salary schedule as all other employees of the District. The annual salary of the Associate Superintendent shall be Range 9 STEP 1, one hundred seventy-eight thousand, five hundred fifty-six dollars (\$178,556.00), payable in twelve (12) equal payments. The Associate Superintendent shall receive an annual salary increase that is not less than the percentage increase granted to the other management employees of the District.

**3. DOCTORAL STIPEND**

The Associate Superintendent shall be entitled to an annual stipend of four (4%) percent of her annual salary for a doctoral degree which is payable in twelve (12) equal payments.

**4. LONGEVITY**

The Associate Superintendent shall be afforded the same opportunity to participate in the District's longevity program as all other management employees, which is payable in twelve (12) equal payments.

**5. FRINGE BENEFITS**

The Associate Superintendent shall be afforded the same opportunity to participate in the District's benefit program as all other management employees. The Associate Superintendent shall receive three hundred fifty dollars (\$350.00) a month to defray her costs of using her personal vehicle for District business.

**6. ORGANIZATIONAL MEMBERSHIP**

The District shall pay full dues for the Associate Superintendent's membership in the Association of California School Administrators (ACSA) or one other as deemed appropriate by the Associate Superintendent.

**7. SALARY CHANGE**

The Board of Education reserves the right to modify the annual salary rate of the Associate Superintendent's contract, provided that the salary shall not be decreased without the Associate Superintendent's consent.

**8. VACATIONS AND SICK LEAVE**

The Associate Superintendent shall be required to render twelve (12) months of full and regular service to the District during each annual period covered by this agreement, except that the Associate Superintendent shall be entitled to twenty-two

(22) days vacation according to District policy. The Associate Superintendent is entitled to cash out up to thirty (30) days of unused vacation annually. In the event of termination of employment, the Associate Superintendent shall be entitled to compensation for unused vacation at the salary range effective during the school year in which the vacation credit was earned, not to exceed 56 days. The Associate Superintendent will be entitled to twenty-two (22) days of earned sick leave per year.

**9. CONDITIONS**

This contract is subject to all applicable laws of the State of California and to the lawful rules and regulations of the California State Board of Education and the Board of Education of the District. Said laws, rules, and regulations are hereby made a part of the terms and conditions of this contract, as though herein set forth.

**10. RENEWAL**

This contract may be terminated by the Board provided that written notice be given to the Associate Superintendent no later than March 15<sup>th</sup> of the final year of the contract.

**11. TERMINATION FOR CAUSE**

The District may terminate this contract at any time for cause, pursuant to the California Education Code. In the event of termination for cause, the District shall have no obligation to pay remaining salary or benefits, except for that salary or benefits accrued by the Associate Superintendent through the effective date of said termination.

**12. EARLY TERMINATION BY ASSOCIATE SUPERINTENDENT**

The Associate Superintendent may terminate her obligations under this contract by giving the District at least thirty (30) days written notice in advance of said termination in which case she shall receive her salary and benefits during said period unless the parties mutually agree in writing to other provisions.

**13. EVALUATION**

The Associate Superintendent shall report to, and be directly responsible to the Superintendent. The Superintendent shall evaluate and assess in writing the performance of the Associate Superintendent at least once a year during the term of this agreement. Said evaluation and assessment shall be reasonably related to the job description of the Associate Superintendent and the goals and objectives of the District.

**14. STATEMENT REQUIRED BY GOVERNMENT CODE SECTION 53260**

Regardless of the term of this Contract, if this Contract is terminated, the maximum cash settlement that the Associate Superintendent may receive shall be in an amount equivalent to her monthly salary multiplied by the number of months left on the unexpired term of the Contract, not to exceed eighteen (18) months.

**15. STATEMENT REQUIRED BY GOVERNMENT CODE SECTION 53243.2**

If this Contract is terminated, any cash settlement related to the termination shall be fully reimbursed to the District if the Associate Superintendent is convicted of a crime involving an abuse of her office or position.

**16. ACTION AT OPEN SESSION OF REGULAR MEETING**

Pursuant to Government Code sections 54956(b) and 54957.6(a), this Contract shall be approved in an open session of a regular meeting of the Board of Education.

**17. SAVINGS CLAUSE**

If any provisions of this Contract are held to be contrary to law by final legislative act or a court of competent jurisdiction inclusive of appeals, if any, such provisions shall not be deemed valid and subsisting except to the extent permitted by law, but all other provisions shall continue in full force and effect.

**18. COMPLETE AGREEMENT**

This Contract is the full and complete agreement between the parties hereto. Any amendment, modifications, or variations from the terms of this Contract shall be in writing and shall be effective only upon approval of such amendment, modification, or variation by the Board and the Associate Superintendent.

IN WITNESS WHEREOF THE PARTIES HERETO HAVE EXECUTED THIS CONTRACT ON THE DATE INDICATED, UPON ACTION OF THE BOARD OF EDUCATION OF THE CHINO VALLEY UNIFIED SCHOOL DISTRICT.

**SIGNATURES OF THE BOARD OF EDUCATION OF THE CHINO VALLEY UNIFIED SCHOOL DISTRICT,**

**County of San Bernardino, California**

\_\_\_\_\_  
Pamela Feix, President Date \_\_\_\_\_

\_\_\_\_\_  
James Na, Vice President Date \_\_\_\_\_

\_\_\_\_\_  
Irene Hernandez-Blair, Clerk Date \_\_\_\_\_

\_\_\_\_\_  
Sylvia Orozco, Member Date \_\_\_\_\_

\_\_\_\_\_  
Andrew Cruz, Member Date \_\_\_\_\_

**SIGNATURE OF THE ASSOCIATE SUPERINTENDENT,  
BUSINESS SERVICES**

\_\_\_\_\_  
Grace Park, Ed.D. Date \_\_\_\_\_



**CONTRACT FOR EMPLOYMENT OF ASSISTANT SUPERINTENDENT**

**between the**

**BOARD OF EDUCATION**

**of the**

**CHINO VALLEY UNIFIED SCHOOL DISTRICT**

**County of San Bernardino, California**

**and**

**Gregory J. Stachura**

**1. OFFER**

This contract is entered into this 28<sup>th</sup> day of June 2018, by the Board of Education of the Chino Valley Unified School District (“District”) and Gregory J. Stachura. The District hereby employs Gregory J. Stachura as Assistant Superintendent, Facilities, Planning & Operations (“Assistant Superintendent”) for a term beginning July 1, 2018, and ending June 30, 2022. This contract may be extended annually, subject to the terms and conditions hereinafter set forth below, and subject to the Assistant Superintendent receiving a satisfactory job performance evaluation on or before March 1<sup>st</sup> of each calendar year by the Superintendent or designee.

**2. SALARY**

The Assistant Superintendent shall be afforded the same opportunity to STEP on the salary schedule as all other employees of the District. The annual salary of the Assistant Superintendent shall be Range 12 STEP 4, one hundred seventy-one thousand, six hundred eighty-eight dollars (\$171,688.00), payable in twelve (12) equal payments. The Assistant Superintendent shall receive an annual salary increase that is not less than the percentage increase granted to the other management employees of the District.

**3. LONGEVITY**

The Assistant Superintendent shall be afforded the same opportunity to participate in the District's longevity program as all other management employees, which is payable in twelve (12) equal payments.

**4. FRINGE BENEFITS**

The Assistant Superintendent shall be afforded the same opportunity to participate in the District's benefit program as all other management employees. The Assistant Superintendent shall receive three hundred fifty dollars (\$350.00) a month to defray her cost of using her personal vehicle for District business.

**5. ORGANIZATIONAL MEMBERSHIP**

The District shall pay full dues for the Assistant Superintendent's membership in the Association of California School Administrators (ACSA) or one other as deemed appropriate by the Assistant Superintendent.

**6. SALARY CHANGE**

The Board of Education reserves the right to modify the annual salary rate of the Assistant Superintendent's contract, provided that the salary shall not be decreased without the Assistant Superintendent's consent.

**7. VACATIONS AND SICK LEAVE**

The Assistant Superintendent shall be required to render twelve (12) months of full and regular service to the District during each annual period covered by this agreement, except that the Assistant Superintendent shall be entitled to twenty-two (22) vacation days according to District policy. The Assistant Superintendent is entitled to cash out up to thirty (30) days of unused vacation annually. In the event of termination of employment, the Assistant Superintendent shall be entitled to compensation for unused vacation at the salary range effective during the school year in which the vacation credit was earned, not to exceed 56 days. The Assistant

Superintendent will be entitled to twenty-two (22) days of earned sick leave per year.

**8. CONDITIONS**

This contract is subject to all applicable laws of the State of California and to the lawful rules and regulations of the California State Board of Education and the Board of Education of the District. Said laws, rules, and regulations are hereby made a part of the terms and conditions of this contract, as though herein set forth.

**9. RENEWAL**

This contract may be terminated by the Board provided that written notice be given to the Assistant Superintendent no later than March 15<sup>th</sup> of the final year of the contract.

**10. TERMINATION FOR CAUSE**

The District may terminate this contract at any time for cause, pursuant to the California Education Code. In the event of termination for cause, the District shall have no obligation to pay remaining salary or benefits, except for that salary or benefits accrued by the Assistant Superintendent through the effective date of said termination.

**11. EARLY TERMINATION BY ASSISTANT SUPERINTENDENT**

The Assistant Superintendent may terminate his obligation under this contract by giving the District at least thirty (30) days written notice in advance of said termination in which case he shall receive his salary and benefits during said period unless the parties mutually agree in writing to other provisions.

**12. EVALUATION**

The Assistant Superintendent shall report to, and be directly responsible to the Superintendent or designee. The Superintendent or designee shall evaluate and assess in writing the performance of the Assistant Superintendent at least once a year during the term of this agreement. Said evaluation and assessment shall be reasonably related to the job description of the Assistant Superintendent and the goals and objectives of the District.

**13. STATEMENT REQUIRED BY GOVERNMENT CODE SECTION 53260**

Regardless of the term of this Contract, if this Contract is terminated, the maximum cash settlement that the Assistant Superintendent may receive shall be in an amount equivalent to her monthly salary multiplied by the number of months left on the unexpired term of the Contract, not to exceed eighteen (18) months.

**14. STATEMENT REQUIRED BY GOVERNMENT CODE SECTION 53243.2**

If this contract is terminated any cash settlement related to the termination shall be fully reimbursed to the District if the Assistant Superintendent is convicted of a crime involving an abuse of her office or position.

**15. ACTION AT OPEN SESSION OF REGULAR MEETING**

Pursuant to Government Code sections 54956(b) and 54957.6(a), this contract shall be approved in an open session of a regular meeting of the Board of Education.

**16. SAVING CLAUSE**

If any provisions of this Contract are held to be contrary to law by final legislative act or a court of competent jurisdiction inclusive of appeals, if any, such provisions shall not be deemed valid and subsisting except to the extent permitted by law, but all other provisions shall continue in full force and effect.

**17. COMPLETE AGREEMENT**

The Contract is the full and complete agreement between the parties hereto. Any amendment, modifications, or variations from the terms of this Contract shall be in writing and shall be effective only upon approval of such amendment, modification, or variation by the Board and the Assistant Superintendent.

IN WITNESS WHEREOF THE PARTIES HERETO HAVE EXECUTED THEIR CONTRACT ON THE DATE INDICATED, UPON ACTION OF THE BOARD OF EDUCATION OF THE CHINO VALLEY UNIFIED SCHOOL DISTRICT.

**SIGNATURES OF THE BOARD OF EDUCATION OF THE CHINO VALLEY UNIFIED SCHOOL DISTRICT,**

**County of San Bernardino, California**

\_\_\_\_\_  
Pamela Feix, President Date \_\_\_\_\_

\_\_\_\_\_  
James Na, Vice President Date \_\_\_\_\_

\_\_\_\_\_  
Irene Hernandez-Blair, Clerk Date \_\_\_\_\_

\_\_\_\_\_  
Andrew Cruz, Member Date \_\_\_\_\_

\_\_\_\_\_  
Sylvia Orozco, Member Date \_\_\_\_\_

**SIGNATURE OF THE ASSISTANT SUPERINTENDENT, FACILITIES, PLANNING, AND OPERATIONS**

\_\_\_\_\_  
Gregory J. Stachura Date \_\_\_\_\_

**CHINO VALLEY UNIFIED SCHOOL DISTRICT**  
**REGULAR MEETING OF THE BOARD OF EDUCATION**  
June 14, 2018

**MINUTES**

<b>I. OPENING BUSINESS</b>
----------------------------

**I.A. CALL TO ORDER – 5:15 P.M.**

1. Roll Call

President Feix called to order the regular meeting of the Board of Education, Thursday, June 14, 2018, at 5:15 p.m. with Cruz, Na, Orozco, and Feix present. Mrs. Blair arrived at 5:20 p.m.

Administrative Personnel

Wayne M. Joseph, Superintendent  
Norm Enfield, Ed.D., Deputy Superintendent  
Sandra H. Chen, Assistant Superintendent, Business Services (absent)  
Lea Fellows, Assistant Superintendent, Human Resources  
Grace Park, Ed.D., Assistant Superintendent, CIIS  
Gregory J. Stachura, Asst. Supt., Facilities, Planning, & Operations

2. Public Comment on Closed Session Items

None.

3. Closed Session

President Feix adjourned to closed session at 5:15 p.m. regarding conference with legal counsel existing and anticipated litigation; a student admission; student readmissions; public employee appointment: coordinator, child welfare & attendance; elementary principal, and elementary and high school assistant principals; conference with labor negotiators A.C.T. and CSEA; and public employee discipline/dismissal/release.

**I.B. RECONVENE TO REGULAR OPEN MEETING: 7:00 P.M.**

1. Report Closed Session Action

President Feix reconvened the regular meeting of the Board of Education at 7:00 p.m. with Blair, Cruz, Na, Orozco, and Feix present. The Board met in closed session from 5:15 p.m. to 6:41 p.m. regarding conference with legal counsel existing and anticipated litigation; a student admission; student readmissions; public employee appointment: coordinator, child welfare & attendance; elementary principal, and elementary and high

school assistant principals; conference with labor negotiators A.C.T. and CSEA; and public employee discipline/dismissal/release.

2. Pledge of Allegiance

Magnolia JHS student Sal Verduzco led the Pledge of Allegiance.

**I.C. EMPLOYEE REPRESENTATIVES' COMMUNICATIONS**

Danny Hernandez, CSEA President, expressed thanks for the professional development provided to staff on Customer Service.

Yvette Farley, CHAMP President, spoke about celebrating successes and failures; and announced CHAMP scholarship recipient, Breanna Cabrera, Don Lugo HS.

**I.D. COMMUNITY LIAISONS' COMMUNICATIONS**

None.

**I.E. COMMENTS FROM THE AUDIENCE ON ITEMS NOT ON THE AGENDA**

John Miller presented a gift to retiring Superintendent Wayne Joseph and spoke about Chino HS achievements; Matthew Morin addressed the Board regarding Chaffey College partnerships; and Sharon Duran expressed thanks to the Chino Valley Unified School District, said that a local small business owner donated graduation outfits to three graduates in need, and spoke about the Chino PD summer program.

**I.F. CHANGES AND DELETIONS**

The following changes were read into the record: Facilities, Planning, and Operations, Item III.D.6., Bid 17-18-28F, Briggs K-8 New Parking Lot, was yellow-sheeted; and Item III.D.7., Bid 17-18-30F, Former El Rancho School Network, was pulled from the agenda.

<b>II. ACTION</b>
-------------------

**II.A. CURRICULUM, INSTRUCTION, INNOVATION, AND SUPPORT**

**II.A.1. Public Hearing Regarding the Local Control and Accountability Plan**

President Feix opened the public hearing regarding the Local Control and Accountability Plan at 7:57 p.m. There were no speakers, and President Feix closed the public hearing at 7:57 p.m.

**II.B. BUSINESS SERVICES**

**II.B.1. Public Hearing Regarding the 2018/2019 Budget**

President Feix opened the public hearing regarding the 2018/2019 budget at 7:57 p.m. There were no speakers, and President Feix closed the public hearing at 7:57 p.m.

**II.C. FACILITIES, PLANNING, AND OPERATIONS**

**II.C.1. Public Hearing on the Change (Increase) of Statutory Developer Fees (Level 1) and Adoption of Resolution 2017/2018-77 Approving a Change in Statutory School Fees Imposed on New Residential and Commercial/Industrial Construction Pursuant to Education Code 17620 and Government Code 65995**

President Feix opened the public hearing regarding the change of statutory developer fees (Level 1) on residential and commercial/industrial development at 7:58 p.m. There were no speakers, and President Feix closed the public hearing at 7:59 p.m. Moved (Na) seconded (Blair) motion carried (4-1, Cruz voted no) to adopt Resolution 2017/2018-77 Approving a Change in Statutory School Fees Imposed on New Residential and Commercial/Industrial Construction Pursuant to Education Code 17620 and Government Code 65995.

**II.C.2. Resolution 2017/2018-76, Declaring Property Surplus and Authorizing Public Sale of Property (Galstian Site)**

Moved (Na) seconded (Blair) carried unanimously (5-0) to adopt Resolution 2017/2018-76, Declaring Property Surplus and Authorizing Public Sale of Property (Galstian Site).

**II.C.3. Resolution 2017/2018-80, Declaring Intention to Consider Proposals for Joint Occupancy Development of District Property**

Moved (Blair) seconded (Na) carried unanimously (5-0) to adopt Resolution 2017/2018-80, Declaring Intention to Consider Proposals for Joint Occupancy Development of District Property.

<b>III. CONSENT</b>
---------------------

Sylvia Orozco pulled for separate action Item III.C.1., specifically student readmission cases 15/16-18, 17/18-12, and 17/18-14. Moved (Na) seconded (Blair) carried unanimously (5-0) to approve the remainder of the consent items as amended.



**III.A. ADMINISTRATION**

**III.A.1. Minutes of the May 16, 2018 Special Meeting, and May 17, 2018 Regular Meeting**

Approved the minutes of the May 16, 2018 special meeting, and May 17, 2018 regular meeting.

**III.B. BUSINESS SERVICES**

**III.B.1. Warrant Register**

Approved/ratified the warrant register.

**III.B.2. Fundraising Activities**

Approved/ratified the fundraising activities.

**III.B.3. Donations**

Accepted the donations.

**III.B.4. Legal Services**

Approved payment for legal services to the law offices of Atkinson, Andelson, Loya, Ruud & Romo; Margaret A. Chidester & Associates; and Fagen Friedman & Fulfrost, LLP.

**III.B.5. 2018/2019 Applications to Operate Fundraising Activities and Other Activities for the Benefit of Students**

Approved/ratified the 2018/2019 applications to operate fundraising activities and other activities for the benefit of students.

**III.C. CURRICULUM, INSTRUCTION, INNOVATION, AND SUPPORT**

**III.C.1. Student Readmission Cases 15/16-18, 16/17-20, 17/18-12, and 17/18-14**

Approved the student readmission case 16/17-20. Moved (Na) seconded (Blair) motion failed (0-5) to approve case 15/16-18; Moved (Na) seconded (Orozco) motion carried (4-0-1, Blair recused herself) to approve cases 17/18-12, and 17/18-14.

**III.C.2. Student Admission Case 17/18-03A**

Approved student admission case 17/18-03A.

**III.C.3. School-Sponsored Trips**

Approved/ratified the following school-sponsored trips: Ayala HS; Chino HS; Chino Hills HS; and Don Lugo HS.

**III.C.4. New Course for Mathematical Reasoning with Connections and Instructional Materials Adoption**

Approved the new course for Mathematical Reasoning with Connections and adopt the instructional materials.

- III.C.5. Course Modification: English 9 Intensive**  
Approved the course modification for English 9 Intensive.
- III.C.6. Course Modification: Library Science**  
Approved the course modification for Library Science.
- III.C.7. Designation of California Interscholastic Federation Representatives to League for 2018/2019**  
Approved the Designation of California Interscholastic Federation Representatives to League for 2018/2019.
- III.C.8. Resolution 2017/2018-81 to Maintain 175 Days of Instructional for Schools on a Multitrack Year-Round Schedule**  
Adopted Resolution 2017/2018-81 to Maintain 175 Days of Instruction for Schools on a Multitrack Year-round Schedule.
- III.C.9. Local Agreement for Child Development Services CSPP-8421 and Adoption of Resolution 2017/2018-82**  
Approved the Local Agreement for Child Development Services CSPP-8421 and adoption of Resolution 2017/2018-82.
- III.C.10. Local Agreement for Child Development Services CCTR-8191 and Adoption of Resolution 2017/2018-83**  
Approved the Local Agreement for Child Development Services CCTR-8191 and adopt Resolution 2017/2018-83.
- III.D. FACILITIES, PLANNING, AND OPERATIONS**
- III.D.1. Purchase Order Register**  
Approved/ratified the purchase order register.
- III.D.2. Agreements for Contractor/Consultant Services**  
Approved/ratified the Agreements for Contractor/Consultant Services.
- III.D.3. Surplus/Obsolete Property**  
Declared the District property surplus/obsolete and authorized staff to sell/dispose of said property.
- III.D.4. Resolutions 2017/2018-78 and 2017/2018-79 for Authorization to Utilize Piggyback Contracts**  
Adopted Resolutions 2017/2018-78 and 2017/2018-79 for authorization to utilize piggyback contracts.
- III.D.5. Bid 17-18-16F, Emergency Preparedness Supplies**  
Awarded Bid 17-18-16F, Emergency Preparedness to More Prepared, LLC.

- III.D.6. Bid 17-18-28F, Briggs K-8 New Parking Lot**  
Awarded Bid 17-18-28F, Briggs K-8 New Parking Lot to Roadway Engineering & Contracting, Inc., as amended.
- III.D.7. Bid 17-18-30F, Former El Rancho School Network**  
This item was pulled from the agenda.
- III.D.8. CUPCCAA Bid 17-18-26I, Former El Rancho ES MPR HVAC System Retrofit**  
Awarded CUPCCAA Bid 17-18-26I, Former El Rancho ES MPR HVAC System Retrofit to Air Control Specialties.
- III.D.9. CUPCCAA Bid 17-18-27I, Former El Rancho ES Primary and Kinder Play Equipment Installation**  
Awarded CUPCCAA Bid 17-18-27I, Former El Rancho ES Primary and Kinder Play Equipment Installation to J2 Builders.
- III.D.10. CUPCCAA Bid 17-18-29I, Former El Rancho ES Gas Line Replacement**  
Awarded CUPCCAA Bid 17-18-29I, Former El Rancho ES Gas Line Replacement to Frasca Plumbing Co.
- III.D.11. CUPCCAA 17-18-31I Former El Rancho ES Directional Boring**  
Awarded CUPCCAA Bid 17-18-31I, Former El Rancho ES Directional Boring to Cal Empire Engineering Inc.
- III.D.12. Rejection of CUPCCAA Bid 17-18-34I, Former El Rancho ES Asphalt and Concrete Repair Authorization to Re-Bid the Project**  
Rejected the CUPCCAA Bid 17-18-34I, Former El Rancho ES Asphalt and Concrete Repair and authorized staff to re-bid the project.
- III.D.13. Notice of Completion for CUPCCAA Projects**  
Approved the Notice of Completion for CUPCCAA Projects.
- III.D.14. Notice of Completion for Bid 17-18-12F, Districtwide Metal Roof Repair**  
Approved the Notice of Completion for Bid 17-18-12F, Districtwide Metal Roof Repair.
- III.E. HUMAN RESOURCES**
- III.E.1. Certificated/Classified Personnel Items**  
Approved/ratified the certificated/classified personnel items.
- III.E.2. Rejection of Claim**  
Rejected the claim and referred it to the District's insurance adjuster.

**III.E.3. Student Teaching Agreement with California State University, San Bernardino**

Approved the student teaching agreement with California State University, San Bernardino.

**IV. INFORMATION**

**IV.A. ADMINISTRATION**

**IV.A.1. Procedure for Board Member Absence and Payment Effective July 1, 2018**

Received for information the notice of procedure for Board member absence and payment effective July 1, 2018, and Sylvia Orozco stated that the procedure should be effective immediately to be in compliance with education code.

**IV.B. CURRICULUM, INSTRUCTION, INNOVATION, AND SUPPORT**

**IV.B.1. New Board Policy and Exhibit 5131.8 Students—Code of Conduct**

Received for information the new Board Policy and Exhibit 5131.8 Students—Code of Conduct.

**IV.B.2. Revision of Board Policy 6117 Instruction—Year-Round Schedules**

Received for information the revision of Board Policy 6117 Instruction—Year-Round Schedules.

**IV.C. HUMAN RESOURCES**

**IV.C.1. Revision of Board Policy 4150, 4250, and 4350 Compensation and Related Benefits—Certificated/Classified Management and Classified Confidential**

Received for information the revision of Board Policy 4150, 4250, and 4350 Compensation and Related Benefits—Certificated/Classified Management and Classified Confidential.

**V. COMMUNICATIONS**

**BOARD MEMBERS AND SUPERINTENDENT**

Sylvia Orozco announced retirees on the agenda; spoke about the new look website; spoke about the customer service professional development training; spoke about community partnerships; attended the Hall of Fame and Employee Retirement Recognition event and commended staff who put it together; said she attended District

graduations; and thanked President Feix for allowing her to give the Chino Hills HS graduation speech.

Andrew Cruz said the new website is well done; spoke about how Mrs. Feix’s relationship with her grandson has affected him in a positive way; spoke about a way dad’s can help protect students at school; commented on a Chino Champion newspaper article regarding parent concerns over comprehensive sex education; and closed by speaking about AB 2943.

Irene Hernandez-Blair said she has obtained legal counsel and that there is nothing that she will share that became known to her during a closed session or District email; spoke about retaliatory conduct; and shared what has been on her mind regarding the Don Lugo HS supervision issue, the investigatory process, handling of the situation, and outcome.

James Na thanked Mrs. Feix and Mrs. Orozco for graduation speeches; spoke about meeting a former Ayala HS student at Home Depot; spoke about paying attention to young people; spoke about helping children; spoke about things that need to be taught at home and not by the legislature; and said he appreciates Superintendent Joseph and the good things he does behind doors.

Superintendent Joseph made no comments.

President Feix asked that the Board be advised exactly on what the District is doing about any changes and implementations relative to Mr. Cruz’s comments on sex education via a presentation to the Board; spoke about Teacher Appreciation Day and community teachers who contribute to student achievement; spoke about a book she found in her grandson’s backpack with photographs of his entire school year; said many of our employees go beyond what is expected with their own time, money, and effort to make a memorable educational experience.

<b>VI. ADJOURNMENT</b>
------------------------

President Feix adjourned the regular meeting of the Board of Education at 8:41 p.m.

---

Pamela Feix, President

---

Irene Hernandez-Blair, Clerk

Recorded by: Patricia Kaylor, Administrative Secretary, Board of Education

**CHINO VALLEY UNIFIED SCHOOL DISTRICT**

**Our Motto:**

Student Achievement • Safe Schools • Positive School Climate  
Humility • Civility • Service

**DATE:** June 28, 2018  
**TO:** Members, Board of Education  
**FROM:** Wayne M. Joseph, Superintendent  
**PREPARED BY:** Sandra H. Chen, Assistant Superintendent, Business Services  
Liz Pensick, Director, Fiscal Services  
**SUBJECT: WARRANT REGISTER**

=====

**BACKGROUND**

Education Code 42650 requires the Board to approve and/or ratify all warrants. These payments are made in the form of warrants, and the warrant (check) form is approved by the County Superintendent.

All items listed are within previously budgeted amounts. There is no fiscal impact beyond currently available appropriations.

Approval of this item supports the goals identified within the District’s Strategic Plan.

**RECOMMENDATION**

It is recommended the Board of Education approve/ratify the warrant register, provided under separate cover.

**FISCAL IMPACT**

\$3,160,176.01 to all District funding sources.

WMJ:SHC:LP:wc

**CHINO VALLEY UNIFIED SCHOOL DISTRICT**

**Our Motto:**

Student Achievement • Safe Schools • Positive School Climate  
Humility • Civility • Service

**DATE:** June 28, 2018  
**TO:** Members, Board of Education  
**FROM:** Wayne M. Joseph, Superintendent  
**PREPARED BY:** Sandra H. Chen, Assistant Superintendent, Business Services  
Liz Pensick, Director, Fiscal Services  
**SUBJECT: FUNDRAISING ACTIVITIES**

=====

**BACKGROUND**

Board Policy 3452 Business and Noninstructional Operations – Student Activity Funds and Board Policy 1230 Community Relations – School Connected Organizations require that fundraising activities be submitted to the Board of Education for approval.

Approval of this item supports the goals identified within the District’s Strategic Plan.

**RECOMMENDATION**

It is recommended the Board of Education approve/ratify the fundraising activities.

**FISCAL IMPACT**

None.

WMJ:SHC:LP:wc

**CHINO VALLEY UNIFIED SCHOOL DISTRICT**  
**June 28, 2018**

<u>SITE/DEPARTMENT</u>	<u>ACTIVITY/DESCRIPTION</u>	<u>DATE</u>
<b><u>Borba ES</u></b>		
ASB	Spirit Wear Sale	7/1/18 - 6/1/19
<b><u>Cattle ES</u></b>		
ASB - 6th Grade	Discount Card Sale	8/30/18 - 9/21/18
<b><u>Chaparral ES</u></b>		
ASB - 6th Grade	Community Discount Card Sale	8/20/18 - 8/31/18
ASB - 6th Grade	Mixed Bag Sale	11/5/18 - 11/16/18
<b><u>Marshall ES</u></b>		
ASB - 5th Grade	Smencil Back-To-School Kick Off	8/13/18 - 8/31/18
<b><u>Cal Aero K-8</u></b>		
PTO	Membership Drive	7/1/18 - 6/30/19
PTO	Spirit Wear Sale	7/1/18 - 6/30/19
PTO	Agenda Sale	7/1/18 - 6/30/19
<b><u>Canyon Hills JHS</u></b>		
Renaissance	Agenda Sale	7/30/18 - 5/31/19
PTSA	After School Snack Sale	8/1/18 - 5/30/19
PTSA	After School Dance Snack Bar	8/1/18 - 5/30/19
PTSA	Marquee Greetings Sale	8/1/18 - 5/30/19
PTSA	Membership Drive	8/1/18 - 5/30/19
PTSA	Spirit Wear Sale	8/1/18 - 5/30/19
Renaissance	Bi-Weekly After School Juice-It-Up Sale	8/16/18 - 5/23/19
Music Club	Back-To-School Night Dinner Sale	8/21/18
PTSA	Book Fair	10/22/18 - 10/28/18
Renaissance	Off Campus Donut Sale	12/3/18 - 12/14/18
Renaissance	Off Campus Candy Sale	1/22/19 - 2/6/19
PTSA	Silent Auction	5/30/19
<b><u>Magnolia JHS</u></b>		
PTA	Fireworks Booth	7/1/18 - 7/4/18



**CHINO VALLEY UNIFIED SCHOOL DISTRICT**  
**June 28, 2018**

<u>SITE/DEPARTMENT</u>	<u>ACTIVITY/DESCRIPTION</u>	<u>DATE</u>
<b><u>Ramona JHS</u></b>		
ASB	Agenda Sale	7/15/18 - 5/15/19
ASB	P.E. Clothing/Lock Sale	7/15/18 - 5/15/19
ASB	Spirit Wear Sale	7/15/18 - 5/15/19
ASB	Yearbook Sale	8/13/18 - 5/27/19
ASB	After School Snack Bar Sale	8/13/18 - 5/31/19
<b><u>Townsend JHS</u></b>		
Travel Club	Off Campus Candy Sale	8/20/18 - 9/21/18
<b><u>Ayala HS</u></b>		
Baseball Boosters	Baseball Home Games Snack Bar	7/2/18 - 6/1/19
Baseball Boosters	Baseball Tournament	7/16/18 - 7/30/18
Choral Boosters	Clothes For A Cause Donation Drive	8/11/18
Theatre Arts Boosters	Clothes For A Cause Donation Drive	8/13/18 - 8/25/18
Choral Boosters	Applebee's Breakfast Sale	9/1/18
Theatre Arts Boosters	Cannataro's Family Nights Out	9/5/18 - 9/6/18
Theatre Arts Boosters	Discount Card Sale	9/17/18 - 9/28/18
Choral Boosters	Off Campus Caramel Apple Sale	9/27/18 - 10/11/18
Theatre Arts Boosters	In-N-Out Family Night Out	10/3/18
Girls Basketball Boosters	Cannataro's Family Night Out	10/11/18
Theatre Arts Boosters	Off Campus Cookie Dough Sale	10/15/18 - 10/26/18
Baseball Boosters	Golf Tournament	10/22/18
Choral Boosters	Poinsettia Sale	11/6/18 - 11/26/18
Baseball Boosters	Comedy Night	12/6/18
Baseball Boosters	Spirit Wear Sale at Baseball Meet & Greet	1/18/19
Baseball Boosters	Adopt a Bulldog Donation Drive	2/15/19 - 5/3/19
<b><u>Chino HS</u></b>		
Basketball Boosters	Fireworks Booth	7/1/18 - 7/4/18
Cross Country Boosters	Jog-A-Thon	7/6/18
Sports Boosters	Tennis Summer Camp	7/9/18 - 8/2/18
Sports Boosters	Golf Summer Camp	7/10/18 - 7/19/18
Aquatics Boosters	Swim-A-Thon	7/12/18
Band Boosters	Cannataro's Family Night Out	7/19/18
Cowboy Huddle	Popcorn Sale at Football Games	7/30/18 - 2/1/19
Cowboy Huddle	Cakes/Pastries Sale at Football Games	7/30/18 - 2/1/19
Cowboy Huddle	Tacos/Burritos Sale at Football Games	7/30/18 - 2/1/19

**CHINO VALLEY UNIFIED SCHOOL DISTRICT**  
**June 28, 2018**

<u>SITE/DEPARTMENT</u>	<u>ACTIVITY/DESCRIPTION</u>	<u>DATE</u>
<b><u>Chino HS</u></b> (cont.)		
CHAPSS	Membership Drive	8/1/18 - 4/1/19
Band Boosters	Off Campus Jewelry Charm Sale	8/14/18 - 8/28/18
Band Boosters	After School Snack Sale	8/20/18 - 8/24/18
Band Boosters	Teriyaki Madness Family Night Out	9/20/18
Band Boosters	Off Campus Tupperware Sale	10/11/18 - 10/25/18
Band Boosters	Chino Invitational Band Review & Tournament	11/3/18
Band Boosters	Off Campus See's Candy Sale	11/15/18 - 11/30/18
Band Boosters	Casa Sanchez Restaurant Family Night Out	12/13/18
Band Boosters	Off Campus Popcorn/Mixed Bag Sale	1/10/19 - 1/24/19
Band Boosters	Titan Burgers Restaurant Day	2/20/19
Band Boosters	Off Campus See's Candy Sale	3/22/19 - 4/4/19
Band Boosters	Yogurtland Family Night Out	4/25/19
<b><u>Don Lugo HS</u></b>		
Football Boosters	Football Banner Sale	6/29/18 - 8/11/18
Floral Club	Holiday/Student/Community Projects Sale	7/1/18 - 5/30/19
Football Boosters	Spirit Wear Sale	8/1/18 - 5/30/19
Sports Boosters	Golf Tournament	10/15/18
ASB	Marquee Announcement Sale	8/13/18 - 6/30/19
ASB	Spirit Poster Sale	8/13/18 - 6/30/19
Journalism	Donation Drive	8/30/18 - 12/15/18
We Remember	Off Campus Popcorn Sale	9/26/18 - 10/3/18
Girls Basketball Boosters	Snap! Raise Donation Drive	10/25/18 - 11/15/18
Girls Basketball Boosters	Carl's Jr. Discount Coupon Sale	11/15/18 - 12/15/18
Girls Basketball Boosters	Basketball Tournament	12/26/18 - 12/31/18
Softball Team	Discount Card Application Sale	1/28/19 - 2/10/19
We Remember	Off Campus Popcorn Sale	3/1/19 - 3/8/19
Renaissance	Walk-A-Thon/Color Run	3/13/19

**CHINO VALLEY UNIFIED SCHOOL DISTRICT**

**Our Motto:**

Student Achievement • Safe Schools • Positive School Climate  
Humility • Civility • Service

**DATE:** June 28, 2018  
**TO:** Members, Board of Education  
**FROM:** Wayne M. Joseph, Superintendent  
**PREPARED BY:** Sandra H. Chen, Assistant Superintendent, Business Services  
Liz Pensick, Director, Fiscal Services  
**SUBJECT: DONATIONS**

=====

**BACKGROUND**

Board Policy 3290 Business and Noninstructional Operations - Gifts, Grants, and Bequests states the Board of Education may accept any bequest or gift of money or property on behalf of the District. All gifts, grants, and bequests shall become property of the District. Use of the gift shall not be impaired by restrictions or conditions imposed by the donor. Approximate values are determined by the donor.

Approval of this item supports the goals identified within the District’s Strategic Plan.

**RECOMMENDATION**

It is recommended the Board of Education accept the donations.

**FISCAL IMPACT**

Any cost for repairs of donated equipment will be a site expense.

WMJ:SHC:LP:wc

**CHINO VALLEY UNIFIED SCHOOL DISTRICT**  
**June 28, 2018**

<u>DEPARTMENT/SITE DONOR</u>	<u>ITEM DONATED</u>	<u>APPROXIMATE VALUE</u>
<b><u>Cortez ES</u></b>		
EI & EI Wood Products	Cash	\$150.00
<b><u>Country Springs ES</u></b>		
Northrop Grumman	Cash	\$200.00
Country Springs PFA	Cash	\$2,062.00
<b><u>Eagle Canyon ES</u></b>		
Your Cause	Cash	\$130.00
Alberto & Erica Diaz	Cash	\$2,500.00
<b><u>Litel ES</u></b>		
Natalie Tuboly	Cash	\$120.00
<b><u>Townsend JHS</u></b>		
Wells Fargo Foundation	Cash	\$130.00
<b><u>Buena Vista HS</u></b>		
Flower Lane Florist	Cash	\$90.00
<b><u>Chino Hills HS</u></b>		
Pacific Life Foundation	Cash	\$3,000.00

**CHINO VALLEY UNIFIED SCHOOL DISTRICT**

**Our Motto:**

Student Achievement • Safe Schools • Positive School Climate  
Humility • Civility • Service

**DATE:** June 28, 2018  
**TO:** Members, Board of Education  
**FROM:** Wayne M. Joseph, Superintendent  
**PREPARED BY:** Sandra H. Chen, Assistant Superintendent, Business Services  
Liz Pensick, Director, Fiscal Services  
**SUBJECT: 2018/2019 APPLICATIONS TO OPERATE FUNDRAISING  
ACTIVITIES AND OTHER ACTIVITIES FOR THE BENEFIT OF  
STUDENTS**

=====

**BACKGROUND**

Administrative Regulation 1230 Community Relations – School Connected Organizations requires that any person or group of people desiring to raise money to benefit a student or students at one or more schools within the District shall request authorization to operate by applying to the Chino Valley Unified School District Board of Education.

Approval of this item supports the goals identified within the District’s Strategic Plan.

**RECOMMENDATION**

It is recommended the Board of Education approve/ratify the 2018/2019 applications to operate fundraising activities and other activities for the benefit of students.

**FISCAL IMPACT**

None.

WMJ:SHC:LP:wc

CHINO VALLEY UNIFIED SCHOOL DISTRICT  
June 28, 2018

**2018/2019 AUTHORIZATION TO OPERATE FUNDRAISING ACTIVITIES  
AND OTHER ACTIVITIES FOR THE BENEFIT OF STUDENTS**

**School**

**Organization**

Chaparral ES	PTO
Country Springs ES	PFA
Eagle Canyon ES	PTA
Magnolia JHS	PFA
Ayala HS	Band & Colorguard Boosters
Chino Hills HS	Aquatics Boosters
Chino Hills HS	Baseball Boosters
Chino Hills HS	Dance Boosters
Chino Hills HS	Football Boosters
Chino Hills HS	General Boosters
Chino Hills HS	2019 Grad Night Boosters
Chino Hills HS	Music Boosters
Chino Hills HS	Spirit Boosters

**CHINO VALLEY UNIFIED SCHOOL DISTRICT**

**Our Motto:**

Student Achievement • Safe Schools • Positive School Climate  
Humility • Civility • Service

**DATE:** June 28, 2018  
**TO:** Members, Board of Education  
**FROM:** Wayne M. Joseph, Superintendent  
**PREPARED BY:** Sandra H. Chen, Assistant Superintendent, Business Services  
Liz Pensick, Director, Fiscal Services  
**SUBJECT: RESOLUTION 2017/2018-84 USE OF 2018/2019 EDUCATION PROTECTION ACCOUNT FUNDS**

=====

**BACKGROUND**

Proposition 30 and Proposition 55 were approved by the voters in California on November 6, 2012, and November 8, 2016, respectively. Proposition 30 added Article XIII, Section 36 to the California Constitution effective November 7, 2012, through December 31, 2017. Proposition 55 added Article XIII, Section 36(e) to the California Constitution effective November 8, 2016, commencing on January 1, 2018.

Article XIII, Section 36(e) created in the state General Fund an Education Protection Account to receive and disburse the revenues derived from the incremental increases in taxes imposed by Article XIII, Section 36(f). Before June 30 of each year, the Superintendent or designee shall estimate the total amount of revenues, less refunds that will be derived from the incremental increases in tax rates made pursuant to Article XIII, Section 36(f) that will be available for transfer in the Education Protection Account during the next fiscal year.

In accordance with Article XIII, Section 36, a public meeting must be held on how the Education Protection Account money will be spent. In compliance with Article XIII, Section 36(e) monies received from the Education Protection Account will be spent as identified in the attachment.

Approval of this item supports the goals identified within the District’s Strategic Plan.

**RECOMMENDATION**

It is recommended the Board of Education adopt Resolution 2017/2018-84 Use of 2018/2019 Education Protection Account Funds.

**FISCAL IMPACT**

Education Protection Account Funds will be restricted to instruction purpose only.

**Chino Valley Unified School District  
Resolution 2017/18-84  
Use of Education Protection Account Funds**

**WHEREAS**, the voters approved Proposition 30 on November 6, 2012, and Proposition 55 on November 8, 2016;

**WHEREAS**, Proposition 30 added Article XIII, Section 36 to the California Constitution effective November 7, 2012, (sun setting 12/31/17) and Proposition 55 Article XIII, Section 36(e) to the California Constitution effective November 8, 2016, (commencing 1/1/18);

**WHEREAS**, the provisions of Article XIII, Section 36(e) create in the state General Fund an Education Protection Account to receive and disburse the revenues derived from the incremental increases in taxes imposed by Article XIII, Section 36(f);

**WHEREAS**, before June 30<sup>th</sup> of each year, the Superintendent or designee shall estimate the total amount of additional revenues, less refunds that will be derived from the incremental increases in tax rates made pursuant to Article XIII, Section 36(f) that will be available for transfer into the Education Protection Account during the next fiscal year;

**WHEREAS**, if the sum determined by the State Controller is positive, the State Controller shall transfer the amount calculated into the Education Protection Account within ten days preceding the end of the fiscal year;

**WHEREAS**, all monies in the Education Protection Account are hereby continuously appropriated for the support of school districts, county offices of education, charter schools and community college districts;

**WHEREAS**, monies deposited in the Education Protection Account shall not be used to pay any costs incurred by the Legislature, the Governor or any agency of state government;

**WHEREAS**, a community college district, county office of education, school district, or charter school shall have the sole authority to determine how the monies received from the Education Protection Account are spent in the school or schools within its jurisdiction;

**WHEREAS**, the Board of Education shall make the spending determinations with respect to monies received from the Education Protection Account in open session of a public meeting of the governing board;

**WHEREAS**, the monies received from the Education Protection Account shall not be used for salaries or benefits for administrators or any other administrative cost;

**WHEREAS**, each community college district, county office of education, school district and charter school shall annually publish on its Internet website an accounting of how much money was received from the Education Protection Account and how that money was spent;



**WHEREAS**, the annual independent financial and compliance audit required of community college districts, county offices of education, school districts and charter schools shall ascertain and verify whether the funds provided from the Education Protection Account have been properly disbursed and expended as required by Article XIII, Section 36 of the California Constitution; and

**WHEREAS**, expenses incurred by community college districts, county offices of education, school districts and charter schools to comply with the additional audit requirements of Article XIII, Section 36 may be paid with funding from the Education Protection Act and shall not be considered administrative costs for purposes of Article XIII, Section 36.

**NOW, THEREFORE, BE IT RESOLVED:**

1. The monies received from the Education Protection Account shall be spent as required by Article XIII, Section 36 and the spending determinations on how the money will be spent shall be made in open session of a public meeting of the Chino Valley Unified School District Board of Education.

2. In compliance with Article XIII, Section 36(e), with the California Constitution, the Chino Valley Unified School District Board of Education has determined to spend the monies received from the Education Protection Act as attached.

**APPROVED, PASSED, AND ADOPTED** by the Board of Education of the Chino Valley Unified School District this 28<sup>th</sup> day of June 2018 at Chino, California.

---

Wayne M. Joseph, Superintendent  
Secretary, Board of Education

2018/2019 Education Protection Account  
Program by Resource Report  
Expenditures by Function - Detail

**Expenditures through: June 30, 2019**  
**For Fund 01, Resource 1400 Education Protection Account**

Description	Object Codes	Amount
<b>AMOUNT AVAILABLE FOR THIS FISCAL YEAR</b>		
Adjusted Beginning Fund Balance	9791-9795	0.00
Revenue Limit Sources	8010-8099	33,238,345.00
Federal Revenue	8100-8299	0.00
Other State Revenue	8300-8599	0.00
Other Local Revenue	8600-8799	0.00
All Other Financing Sources and Contributions	8900-8999	0.00
Deferred Revenue	9650	0.00
<b>TOTAL AVAILABLE</b>		<b>33,238,345.00</b>
<b>EXPENDITURES AND OTHER FINANCING USES</b>		
<b>(Objects 1000-7999)</b>		
Instruction	1000-1999	33,238,345.00
Instruction-Related Services		
Instructional Supervision and Administration	2100-2150	0.00
AU of a Multidistrict SELPA	2200	0.00
Instructional Library, Media, and Technology	2420	0.00
Other Instructional Resources	2490-2495	
School Administration	2700	0.00
Pupil Services		
Guidance and Counseling Services	3110	0.00
Psychological Services	3120	0.00
Attendance and Social Work Services	3130	0.00
Health Services	3140	0.00
Speech Pathology and Audiology Services	3150	0.00
Pupil Testing Services	3160	0.00
Pupil Transportation	3600	0.00
Food Services	3700	0.00
Other Pupil Services	3900	0.00
Ancillary Services	4000-4999	0.00
Community Services	5000-5999	0.00
Enterprise	6000-6999	0.00
General Administration	7000-7999	0.00
Plant Services	8000-8999	0.00
Other Outgo	9000-9999	0.00
<b>TOTAL EXPENDITURES AND OTHER FINANCING USES</b>		<b>33,238,345.00</b>
<b>BALANCE (Total Available minus Total Expenditures and Other Financing Uses)</b>		<b>0.00</b>

**CHINO VALLEY UNIFIED SCHOOL DISTRICT**

**Our Motto:**

Student Achievement • Safe Schools • Positive School Climate  
Humility • Civility • Service

**DATE:** June 28, 2018  
**TO:** Members, Board of Education  
**FROM:** Wayne M. Joseph, Superintendent  
**PREPARED BY:** Sandra H. Chen, Assistant Superintendent, Business Services  
Liz Pensick, Director, Fiscal Services  
**SUBJECT: RESOLUTION 2017/2018-85 TRANSFERS OF APPROPRIATIONS  
FOR 2018/2019**

=====

**BACKGROUND**

Pursuant to Education Code 42600 through 42602, school districts are required to approve a resolution for budget transfers and adjustments and file it with the San Bernardino County Superintendent of Schools each year.

Approval of this item supports the goals identified within the District’s Strategic Plan.

**RECOMMENDATION**

It is recommended the Board of Education adopt Resolution 2017/2018-85 Transfers of Appropriations for 2018/2019.

**FISCAL IMPACT**

None.

WMJ:SHC:LP:wc

**Chino Valley Unified School District  
Resolution 2017/2018-85  
Transfers of Appropriations for 2018/2019**

**WHEREAS**, the Board of Education of the Chino Valley Unified School District has determined that during the fiscal year budget revisions become necessary to bring the budgeted revenues and expenditures in balance with actual receipts and expenses;

**WHEREAS**, by making these appropriation adjustments to actuals, the District will reflect a more realistic picture of actual spending patterns of funds; and

**WHEREAS**, the Board of Education of the Chino Valley Unified School District has determined that additional income is assured in excess of the amounts previously budgeted and the timely posting of adjustments will keep each account up to date with accurate uncommitted balances.

**NOW, THEREFORE, BE IT RESOLVED** pursuant to Education Code Sections 42600 through 42602, the Chino Valley Unified School District may appropriate any such funds, identify and make such transfers as needed throughout the 2018/2019 fiscal year.

**BE IT FURTHER RESOLVED** the Board of Education of the Chino Valley Unified School District authorizes staff to process the necessary transfers of appropriation to revise budget amounts during the course of the fiscal year to allow appropriation of excess funds, transfers between designated and/or un-appropriated fund balances and any expenditure classifications, or balance any expenditure classification of the budget.

**APPROVED, PASSED, AND ADOPTED** by the Board of Education of the Chino Valley Unified School District this 28<sup>th</sup> day of June 2018 at Chino, California.

---

Wayne M. Joseph, Superintendent  
Secretary, Board of Education

**CHINO VALLEY UNIFIED SCHOOL DISTRICT**

**Our Motto:**

Student Achievement • Safe Schools • Positive School Climate  
Humility • Civility • Service

**DATE:** June 28, 2018  
**TO:** Members, Board of Education  
**FROM:** Wayne M. Joseph, Superintendent  
**PREPARED BY:** Norm Enfield, Ed.D., Deputy Superintendent  
Stephanie Johnson, Director, Student Support Services  
**SUBJECT: STUDENT EXPULSION CASE 17/18-33**

=====

**BACKGROUND**

The Board of Education has established policies and standards of behavior in order to promote learning and protect the safety and well-being of all students. When these policies and standards are violated, it may be necessary to suspend or expel a student from regular classroom instruction.

Expulsion is an action taken by the Board for severe or prolonged breaches of discipline by a student. Except for single acts of a grave nature, expulsion is used only when there is a history of misconduct, when other forms of discipline, including suspension, have failed to bring about proper conduct, or when the student’s presence causes a continuing danger to him/herself or others.

A student may be expelled only by the Board of Education. The Board shall expel, as required by law, any student found to have committed certain offenses listed in Education Code 48915.

Approval of this item supports the goals identified within the District’s Strategic Plan.

**RECOMMENDATION**

Based upon the recommendation of the Expulsion Hearing Administrative Panel, it is recommended the Board of Education approve student expulsion case 17/18-33.

**FISCAL IMPACT**

None.

WMJ:NE:SJ:ss

**CHINO VALLEY UNIFIED SCHOOL DISTRICT**

**Our Motto:**

Student Achievement • Safe Schools • Positive School Climate  
Humility • Civility • Service

**DATE:** June 28, 2018  
**TO:** Members, Board of Education  
**FROM:** Wayne M. Joseph, Superintendent  
**PREPARED BY:** Grace Park, Ed.D., Assistant Superintendent, Curriculum, Instruction, Innovation, and Support  
**SUBJECT: SCHOOL-SPONSORED TRIPS**

=====

**BACKGROUND**

The Board of Education recognizes that school-sponsored trips are an important component of a student’s development and supplement and enrich the classroom learning experience. School-sponsored trips may be conducted in connection with the District’s course of study or school related social, educational, cultural, athletic, school band activities, or other extracurricular or cocurricular activities. Resources will be identified and established at the school site to assist economically disadvantaged students in obtaining funding for field trips and, in some cases, student travel. School sponsored trips that require overnight stay or are in excess of 250 miles (one way) require board approval.

Approval of this item supports the goals identified within the District’s Strategic Plan.

**RECOMMENDATION**

It is recommended the Board of Education approve/ratify the following school-sponsored trips:

<b>School-Sponsored Trips</b>	<b>Date</b>	<b>Fiscal Impact</b>
Site: Ayala HS Event: Theatre Arts - Production and Performance Summer Retreat Place: Big Bear Lake, CA Chaperone: 11 students/5 chaperones	July 23-25, 2018	Cost: \$150.00 per student Funding Source: Parents
Site: Ayala HS Event: Cross Country - Big Bear Running Camp Place: Big Bear Lake, CA Chaperone: 28 students/5 chaperones	July 23-27, 2018	Cost: \$350.00 per student Funding Source: Parents and Fundraising

Site: Ayala HS Event: Girls' Golf Team - East Coast Summer Pre-Season Prep Trip Place: Philadelphia, PA; New York, NY; and Toms River, NJ Chaperone: 8 students/2 chaperones	August 4-9, 2018	Cost: \$900.00 per student Funding Source: Fundraising
Site: Chino HS Event: Yearbook Club - Yearbook Summer Camp Place: Malibu, CA Chaperone: 5 students/1 chaperone	July 30-August 2, 2018	Cost: \$550.00 per student Funding Source: Scholarships
Site: Chino HS Event: Cross Country Team - Country Camp Place: Big Bear Lake, CA Chaperone: 30 students/6 chaperones	August 5-9, 2018	Cost: \$150.00 per student Funding Source: Fundraising
Site: Chino Hills HS Event: California Interscholastic Federation Competitive Cheer Team - National Cheerleaders Association Masters Speed Camp Place: Indian Wells, CA Chaperone: 22 students/3 chaperones	July 30-August 1, 2018	Cost: \$345.00 per student Funding Source: Parents

**FISCAL IMPACT**

None.

WMJ:GP:rtr

**CHINO VALLEY UNIFIED SCHOOL DISTRICT**

**Our Motto:**

Student Achievement • Safe Schools • Positive School Climate  
Humility • Civility • Service

**DATE:** June 28, 2018  
**TO:** Members, Board of Education  
**FROM:** Wayne M. Joseph, Superintendent  
**PREPARED BY:** Norm Enfield, Ed.D., Deputy Superintendent  
**SUBJECT:** **NEW BOARD POLICY AND EXHIBIT 5131.8 STUDENTS – CODE OF CONDUCT**

=====

**BACKGROUND**

Board policies, administrative regulations, and bylaws of the Board are routinely developed and revised as a result of changes in law, mandates, federal regulations, and current District practice. Board Policy and Exhibit 5131.8 Students – Code of Conduct is being created to develop consistent District standards and expectations as it relates to student code of conduct. The exhibit specifically requires a District student participating in a co-curricular or extracurricular activity to acknowledge his/her commitment to the student code of conduct. This item was presented to the Board on June 14, 2018, for information.

New language is provided in UPPER CASE.

Approval of this item supports the goals identified within the District’s Strategic Plan.

**RECOMMENDATION**

It is recommended the Board of Education approve the new Board Policy and Exhibit 5131.8 Students – Code of Conduct.

**FISCAL IMPACT**

None.

WMJ:NE:smr



**CODE OF CONDUCT**

CHINO VALLEY UNIFIED SCHOOL DISTRICT'S HIGH SCHOOL PROGRAMS PROVIDE STUDENTS WITH STRONG ACADEMICS AND THE OPPORTUNITY TO PARTICIPATE IN CO-CURRICULAR AND EXTRACURRICULAR ACTIVITIES INCLUDING ATHLETICS, SCHOOL CLUBS, PERFORMING ARTS, AND STUDENT GOVERNMENT. ALL STUDENTS ARE CONSIDERED STUDENT AMBASSADORS TO THE PUBLIC AND SERVE AS THE LEADERS OF THE STUDENT BODY.

**A. APPLICABILITY**

THIS STUDENT CODE OF CONDUCT APPLIES TO STUDENT BEHAVIOR WHILE ON SCHOOL GROUNDS, WHILE GOING TO OR COMING FROM SCHOOL, WHILE AT SCHOOL ACTIVITIES ON OR OFF CAMPUS, AND WHILE ON DISTRICT TRANSPORTATION. STUDENTS MAY ALSO BE SUBJECT TO DISCIPLINE FOR ANY OFF-CAMPUS CONDUCT DURING NONSCHOOL HOURS WHICH POSES A THREAT OR DANGER TO THE SAFETY OF STUDENTS, STAFF, OR SUBSTANTIALLY DISRUPTS SCHOOL ACTIVITIES.

CONSEQUENCES FOR VIOLATING THIS STUDENT CODE OF CONDUCT WILL BE CARRIED OVER FROM ONE SCHOOL YEAR TO THE FOLLOWING SCHOOL YEAR UNTIL CONSEQUENCES ARE COMPLETED IN FULL.

**B. CONSENT TO BE GOVERNED BY STUDENT CODE OF CONDUCT FOR CO-CURRICULAR AND EXTRACURRICULAR ACTIVITIES**

STUDENTS MUST SIGN AND TURN IN TO THE COACH/ADVISOR THE CODE OF CONDUCT FORM.

**C. ELIGIBILITY REQUIREMENTS**

1. **ACADEMIC STANDARDS:** STUDENTS MUST DEMONSTRATE SATISFACTORY EDUCATIONAL PROGRESS IN THE PREVIOUS GRADING PERIOD: (BOARD POLICY 6145 – EXTRACURRICULAR/CO-CURRICULAR ACTIVITIES)
  - A. THE STUDENT MUST MAINTAIN A GRADE POINT AVERAGE OF 2.0 ON A 4.0 SCALE IN ACCORDANCE WITH ADMINISTRATIVE REGULATION 6145 – EXTRACURRICULAR/CO-CURRICULAR ACTIVITIES.
  - B. THE STUDENT MUST EARN PASSING GRADES IN A MINIMUM OF FOUR (4) CLASSES DURING THE LAST APPLICABLE PROGRESS REPORT/GRADING PERIOD.

**CODE OF CONDUCT (CONT.)**

- C. CREDITS EARNED IN SUMMER SCHOOL MAY BE APPLIED TOWARDS ELIGIBILITY REQUIREMENTS. SUMMER SCHOOL GRADES MAY BE COMBINED WITH SECOND SEMESTER GRADES OF THE PREVIOUS SCHOOL YEAR TO DETERMINE THE ELIGIBILITY FOR THE NEXT GRADING PERIOD.
  - D. STUDENT GRADE CHECKS WILL BE DONE AT EVERY PROGRESS REPORT AND/OR MOST RECENT GRADING PERIOD.
2. **ATTENDANCE:** A STUDENT MUST NOT HAVE MORE THAN EIGHT (8) INCIDENTS OF PERIOD TRUANCY DURING THE PREVIOUS GRADING PERIOD. TRUANCY IS DEFINED AS AN ABSENCE FROM CLASS WITHOUT PARENT OR TEACHER PERMISSION FOR EITHER ALL, OR A PORTION, OF A SCHOOL DAY.

A STUDENT MUST ATTEND A FULL DAY OF SCHOOL ON THE DAY(S) OF PARTICIPATION IN THE CO-CURRICULAR OR EXTRACURRICULAR ACTIVITY. IF SAID ACTIVITY IS TO TAKE PLACE DURING THE INSTRUCTIONAL DAY OR SOME PORTION THEREOF, THE STUDENT IS TO ATTEND ALL CLASSES UP TO THE TIME THE ACTIVITY IS TO OCCUR.

3. **CALIFORNIA INTERSCHOLASTIC FEDERATION (CIF) REQUIREMENTS (STUDENT ATHLETE):**
- A. CURRENTLY ENROLL IN A MINIMUM OF 20 SEMESTER PERIODS OF WORK;
  - B. MUST HAVE PASSED A MINIMUM OF 20 SEMESTER PERIODS OF WORK AT THE COMPLETION OF THE LAST REGULAR SCHOOL GRADING PERIOD;
  - C. BE SUCCESSFULLY PROGRESSING TOWARDS THE GRADUATION REQUIREMENTS; AND
  - D. MAINTAIN GPA STANDARDS SET BY THE DISTRICT.

**CODE OF CONDUCT (CONT.)****D. FAILURE TO MEET ELIGIBILITY REQUIREMENTS:**

THE PRINCIPAL OR DESIGNEE SHALL PROVIDE WRITTEN NOTICE TO STUDENT, PARENTS/GUARDIANS AND COACH/ADVISOR WHEN A STUDENT BECOMES INELIGIBLE TO PARTICIPATE. STUDENTS ENROLLED IN PERFORMANCE ACTIVITY CLASSES MAY BE ALLOWED TO REMAIN IN THE CLASS BUT WILL BE INELIGIBLE FOR PARTICIPATION AND PERFORMANCES.

**E. CODE OF CONDUCT STANDARDS**

STUDENTS ARE REQUIRED TO FOLLOW THE DISTRICT'S BOARD POLICIES AND ADMINISTRATIVE REGULATIONS REGARDING STUDENT CONDUCT, IN ADDITION TO THIS STUDENT CODE OF CONDUCT POLICY. THE FOLLOWING IS NOT AN EXHAUSTIVE LIST OF PROHIBITED CONDUCT THAT WILL SUBJECT A STUDENT TO DISCIPLINE:

- VIOLATION OF SCHOOL RULES, DISTRICT POLICIES OR ADMINISTRATIVE REGULATIONS RELATING TO STUDENT CONDUCT;
- VIOLATION OF THE CALIFORNIA EDUCATION CODE AND SHED AN UNFAVORABLE LIGHT ON THE DISTRICT OR SCHOOL;
- VIOLATION OF EXTRACURRICULAR/CO-CURRICULAR ATTENDANCE RULES;
- USE OR POSSESSION OF ALCOHOLIC BEVERAGES, TOBACCO, NARCOTICS, DANGEROUS DRUGS OR "LOOK-ALIKE" SUBSTANCES;
- INVOLVEMENT IN THEFT OR DISHONESTY, INCLUDING ACADEMIC DISHONESTY;
- COMMISSION OF ANY ACT OF DEFIANCE, EITHER IN LANGUAGE OR ACTION AGAINST ANY SCHOOL EMPLOYEE;
- GAMBLING;
- FIGHTING;
- VANDALISM;
- ANY OTHER OFFENSE THAT MAY RESULT IN A SUSPENSION UNDER EDUCATION CODE 48900/48915.

**F. VIOLATION OF CODE OF CONDUCT STANDARDS:**

STUDENTS IN VIOLATION OF THIS STUDENT CODE OF CONDUCT MAY BE SUBJECT TO DISCIPLINE IN ACCORDANCE WITH BOARD POLICY AND ADMINISTRATIVE REGULATION 6145 – EXTRACURRICULAR AND CO-CURRICULAR ACTIVITIES.

PROGRESSIVE DISCIPLINARY ACTION MAY BE ENFORCED BY THE STUDENT'S COACH/ADVISOR.

**CODE OF CONDUCT (CONT.)**

- **1<sup>ST</sup> OFFENSE:** WARNING – VERBAL COMMUNICATION BETWEEN STUDENT AND COACH/ADVISOR;
- **2<sup>ND</sup> OFFENSE:** PARENT CONTACT – POSSIBLE LOSS OF PARTICIPATION IN EXTRACURRICULAR/CO-CURRICULAR ACTIVITY. STUDENT REMAINS ELIGIBLE TO ATTEND PRACTICES, ACTIVITIES, EVENTS AND/OR COMPETITIONS.
- **3<sup>RD</sup> OFFENSE:** MEETING WITH STUDENT, PARENT, COACH/ADVISOR, AND SCHOOL ATHLETIC/ACTIVITIES DIRECTOR – POSSIBLE SUSPENSION FROM EXTRACURRICULAR/CO-CURRICULAR ACTIVITY; POSSIBLY FORFEIT AWARD/LETTER.
- **4<sup>TH</sup> OFFENSE:** MEETING WITH STUDENT, PARENT, COACH/ADVISOR, AND SCHOOL ATHLETIC/ACTIVITIES DIRECTOR – POSSIBLE DISMISSAL FROM EXTRACURRICULAR/CO-CURRICULAR ACTIVITY; POSSIBLY FORFEIT AWARD/LETTER.
- **EXCEPTIONAL CIRCUMSTANCES:** SOME OFFENSES MAY BE SERIOUS ENOUGH TO WARRANT SKIPPING THE PROGRESSIVE DISCIPLINARY STEPS. THE STUDENT AND PARENT OR GUARDIAN MAY EXERCISE APPEAL RIGHTS.

A COACH/ADVISOR'S RECOMMENDATION TO SUSPEND OR DISMISS A STUDENT MUST BE APPROVED BY THE SCHOOL'S ATHLETIC/ACTIVITIES DIRECTOR. WHEN APPROPRIATE, THE SUPERINTENDENT OR DESIGNEE SHALL NOTIFY LOCAL LAW ENFORCEMENT.

**G. DUE PROCESS PROCEDURES:**

THE DISTRICT ACTS IN THE BEST INTEREST OF STUDENTS AND RESPECTS THE STUDENT'S RIGHT TO DUE PROCESS. STUDENTS WHO ARE SUSPENDED OR DISMISSED FROM AN EXTRACURRICULAR/CO-CURRICULAR ACTIVITY WILL BE PROVIDED DUE PROCESS.

1. A STUDENT WHO IS SUSPENDED OR DISMISSED FROM AN EXTRACURRICULAR/CO-CURRICULAR ACTIVITY IS ENTITLED TO BE INFORMED OF THE CONSEQUENCES AGAINST HIM/HER AND AN INFORMAL MEETING WITH THE STUDENT, PARENT OR GUARDIAN, COACH/ADVISOR AND SCHOOL ATHLETIC/ACTIVITIES DIRECTOR.

**CODE OF CONDUCT (CONT.)**

2. EXCEPT WHERE STATED OTHERWISE, A STUDENT OR A STUDENT'S PARENT OR GUARDIAN, MAY APPEAL A SUSPENSION OR DISMISSAL IMPOSED BY THE COACH/ADVISOR AND SCHOOL ATHLETIC/ACTIVITIES DIRECTOR.
3. A STUDENT, PARENT, OR GUARDIAN MAY INITIATE AN APPEAL IN WRITING TO THE SCHOOL PRINCIPAL'S OFFICE WITHIN FIVE (5) SCHOOL DAYS AFTER THE DISCIPLINARY ACTION IS IMPOSED.

THE APPEAL COMMITTEE SHALL CONSIST OF THE ACTIVITIES/ATHLETIC DIRECTOR, AN ADMINISTRATOR, ADVISOR/COACH OF THE PROGRAM INVOLVED AND A FACULTY MEMBER AT LARGE. THE STUDENT AND PARENT/GUARDIAN MUST ATTEND THE HEARING. THE DECISION OF THE APPEAL COMMITTEE SHALL BE FINAL.

1. WHILE THE APPEAL PERIOD IS PENDING, THE CONSEQUENCES SHALL NORMALLY BE SERVED, UNLESS DEFERRED BY THE PRINCIPAL.

**H. REINSTATEMENT**

**SUSPENSION** - STUDENTS WHO ARE SUSPENDED FROM SCHOOL FOR ANY REASON ARE IN VIOLATION OF THIS STUDENT CODE OF CONDUCT AND ARE PROHIBITED FROM PARTICIPATION IN EXTRACURRICULAR/CO-CURRICULAR ACTIVITIES INCLUDING PRACTICES, ACTIVITIES, EVENTS AND/OR COMPETITIONS.

AT ANY TIME DURING THE SCHOOL YEAR, THE PRINCIPAL MAY DECLARE ANY STUDENT IMMEDIATELY INELIGIBLE, WHEN HE/SHE HAS BEEN SUSPENDED OR ARRESTED FOR THE USE OR POSSESSION OF NARCOTICS, ALCOHOL, WEAPONS, ASSAULT AGAINST A TEACHER, SCHOOL EMPLOYEE OR OTHER STUDENT, OR AS A RESULT OF ANY SITUATION THAT THE PRINCIPAL FEELS IS SERIOUS ENOUGH TO REQUIRE SUCH ACTION.

**REINSTATEMENT** - STUDENTS WHO HAVE BEEN SUSPENDED FROM PARTICIPATION IN CO-CURRICULAR OR EXTRACURRICULAR ACTIVITIES MUST APPLY TO THE REINSTATEMENT COMMITTEE FOR REINSTATEMENT. AN APPLICATION MUST BE MADE IN WRITING AND SUBMITTED TO THE SCHOOL PRINCIPAL'S OFFICE. THIS IS THE SOLE RESPONSIBILITY OF THE STUDENT. A HEARING WILL BE HELD THE FOLLOWING MONDAY FOLLOWING THE RECEIPT OF THE APPLICATION FOR REINSTATEMENT.

**CODE OF CONDUCT (CONT.)**

THE REINSTATEMENT COMMITTEE SHALL CONSIST OF THE ACTIVITIES/ATHLETIC DIRECTOR, AN ADMINISTRATOR, ADVISOR/COACH OF THE PROGRAM INVOLVED, AND A FACULTY MEMBER AT LARGE. THE STUDENT AND PARENT/GUARDIAN MUST ATTEND THE HEARING. THE DECISION OF THE REINSTATEMENT COMMITTEE SHALL BE FINAL.

AN EXTENDED ABSENCE FROM THE CO-CURRICULAR OR EXTRACURRICULAR ACTIVITY MAY CAUSE ORGANIZATIONAL ADJUSTMENTS TO BE MADE BY THE COACH/ADVISOR. THE RESTORATION OF ELIGIBILITY TO PARTICIPATE IN THE CO-CURRICULAR OR EXTRACURRICULAR ACTIVITY DOES NOT GUARANTEE PLACEMENT ON THE TEAM, IN COMPETITIONS, OR WITHIN THE ORGANIZATION.

**CHINO VALLEY UNIFIED SCHOOL DISTRICT**  
POLICY ADOPTED:

**CODE OF CONDUCT****CODE OF CONDUCT FORM**

ALL SCHOOL ACTIVITIES, CO-CURRICULAR AND EXTRACURRICULAR, IN THE CLASSROOM AND ON THE PLAYING FIELD/COMPETITION PLATFORM, MUST BE CONGRUENT WITH THE SCHOOL'S STATED GOALS AND OBJECTIVES ESTABLISHED FOR THE INTELLECTUAL, PHYSICAL, SOCIAL, AND MORAL DEVELOPMENT OF ITS STUDENTS. IT IS WITHIN THIS CONTEXT THAT THE FOLLOWING CODE OF ETHICS FOR STUDENT ATHLETES IS PRESENTED.

AS A STUDENT, I UNDERSTAND THAT IT IS MY RESPONSIBILITY TO:

1. PLACE ACADEMIC ACHIEVEMENT AS THE HIGHEST PRIORITY BY MAINTAINING A MINIMUM 2.0 GRADE POINT AVERAGE.
2. SHOW RESPECT FOR OTHERS (TEAMMATES, PLAYERS, OPPONENTS, OFFICIALS, COACHES, AND ADVISORS).
3. RESPECT THE INTEGRITY AND JUDGMENT OF OFFICIALS (REFEREES, UMPIRES, JUDGES, ETC).
4. EXHIBIT FAIR PLAY, SPORTSMANSHIP, AND PROPER CONDUCT ON-AND-OFF THE PLAYING FIELD/COMPETITION PLATFORM.
5. MAINTAIN A HIGH LEVEL OF SAFETY AWARENESS.
6. REFRAIN FROM THE USE OF PROFANITY, VULGARITY, AND OTHER OFFENSIVE LANGUAGE AND GESTURES.
7. ADHERE TO THE EXPECTATIONS ESTABLISHED BY THE COACH/ADVISOR.
8. ADHERE TO THE ESTABLISHED RULES AND STANDARDS OF THE COMPETITION OR GAME TO BE PLAYED.
9. RESPECT ALL EQUIPMENT AND FACILITIES. USE THEM SAFELY AND APPROPRIATELY.
10. REFRAIN FROM THE USE OF ALCOHOL, TOBACCO, MARIJUANA, VAPE PIPES, ILLEGAL AND NON-PRESCRIPTIVE DRUG, ANABOLIC STEROIDS OR ANY SUBSTANCE TO INCREASE PHYSICAL DEVELOPMENT OR PERFORMANCE THAT IS NOT APPROVED BY THE UNITED STATES FOOD AND DRUG ADMINISTRATION, SURGEON GENERAL OF THE UNITED STATES OR AMERICAN MEDICAL ASSOCIATION (AMA).
11. KNOW AND FOLLOW ALL STATE, SECTION, COMPETITION, AND SCHOOL ATHLETIC/ACTIVITY RULES AND REGULATIONS AS THEY PERTAIN TO ELIGIBILITY AND SPORTS PARTICIPATION.
12. WIN WITH CHARACTER; LOSE WITH DIGNITY.

**CODE OF CONDUCT (CONT.)**

**CODE OF CONDUCT FORM (CONT.)**

- 13. WILL NOT HARASS (PHYSICAL, WRITTEN, VERBAL, OR OTHER MEANS), SEXUALLY HARASS, THREATEN, INTIMIDATE, RETALIATE, CYBERBULLY, CAUSE BODILY INJURY TO, OR COMMIT HATE VIOLENCE AGAINST ANY OTHER STUDENT OR SCHOOL PERSONNEL.

AS A CONDITION OF MEMBERSHIP IN THE CIF, ALL SCHOOLS SHALL ADOPT POLICIES PROHIBITING THE USE AND ABUSE OF ANDROGENIC/ANABOLIC STEROIDS. ALL MEMBER SCHOOLS SHALL HAVE PARTICIPATING STUDENTS AND THEIR PARENTS, LEGAL GUARDIAN/CAREGIVER AGREE THAT THE ATHLETE WILL NOT USE STEROIDS WITHOUT THE WRITTEN PRESCRIPTION OF A FULLY LICENSED PHYSICIAN (AS RECOGNIZED BY THE AMA) TO TREAT A MEDICAL CONDITION (ARTICLE 503.I).

A STUDENT WHO IS FOUND TO HAVE VIOLATED THIS ADMINISTRATIVE REGULATION MAY BE RESTRICTED FROM PARTICIPATING IN ATHLETICS/ACTIVITY AND MAY BE SUBJECT TO APPEARANCE BEFORE THE SCHOOL'S CODE OF CONDUCT COMMITTEE FOR DISCIPLINARY PROCEDURES MAY INCLUDE, BUT NOT LIMITED TO, SUSPENSION OR EXPULSION IN ACCORDANCE WITH LAW, BOARD POLICY AND ADMINISTRATIVE REGULATION.

WE RECOGNIZE THAT UNDER CIF BYLAW 202, THERE COULD BE PENALTIES FOR FALSE OR FRAUDULENT INFORMATION. WE ALSO UNDERSTAND THAT THE CHINO VALLEY UNIFIED SCHOOL DISTRICT WILL ENFORCE ITS BOARD POLICY 5131 – CONDUCT, AND POLICY REGARDING THE USE OF ILLEGAL DRUGS FOR ANY VIOLATIONS OF THESE RULES.

BY SIGNING BELOW, BOTH THE PARTICIPATING STUDENT OR STUDENT ATHLETE, AND THE PARENT, LEGAL GUARDIAN/CAREGIVER HEREBY COMMIT TO THE CODE OF CONDUCT.

\_\_\_\_\_  
PRINT STUDENT'S NAME

\_\_\_\_\_  
STUDENT SIGNATURE

\_\_\_\_\_  
DATE

\_\_\_\_\_  
PARENT/GUARDIAN/CAREGIVER SIGNATURE

\_\_\_\_\_  
DATE



**CODE OF CONDUCT (CONT.)**

**CODE OF CONDUCT COMMITTEE FORM (CONT.)**

STUDENT: \_\_\_\_\_ GRADE: \_\_\_\_\_ ID#: \_\_\_\_\_

ACTIVITY/SPORT: \_\_\_\_\_

COACH/ADVISOR: \_\_\_\_\_

THE CODE IS INSTITUTED UPON THE BELIEF THAT STUDENTS WHO ARE INVOLVED IN CO-CURRICULAR, EXTRACURRICULAR AND SCHOOL ACTIVITIES BE POSITIVE ROLE MODELS AND ARE EXPECTED TO ADHERE TO THE CHINO VALLEY UNIFIED SCHOOL DISTRICT'S CODE OF CONDUCT. STUDENTS WHO HAVE BEEN SUSPENDED UNDER CALIFORNIA EDUCATION CODE 48900/48915 WILL HAVE VIOLATED THE DISTRICT'S CODE OF CONDUCT.

THE ATHLETIC/ACTIVITIES DIRECTOR OF \_\_\_\_\_ HIGH SCHOOL MAKES A RECOMMENDATION AS FOLLOWS:

SUSPENSION – DURATION:

\_\_\_\_\_

DISMISSAL – DURATION:

\_\_\_\_\_

OTHER:

\_\_\_\_\_

\_\_\_\_\_

\_\_\_\_\_

**DUE PROCESS PROCEDURES**

THE DISTRICT ACTS IN THE BEST INTEREST OF STUDENTS AND RESPECTS THE STUDENT'S RIGHT TO DUE PROCESS. STUDENTS WHO ARE SUSPENDED OR DISMISSED FROM A CO-CURRICULAR OR EXTRACURRICULAR ACTIVITY MAY APPEAL A SUSPENSION OR DISMISSAL IMPOSED BY THE COACH/ADVISOR AND SCHOOL ATHLETIC/ACTIVITIES DIRECTOR IN ACCORDANCE WITH THE DISTRICT'S STUDENT CODE OF CONDUCT.

**CODE OF CONDUCT (CONT.)**

**CODE OF CONDUCT COMMITTEE FORM (CONT.)**

A STUDENT, PARENT, OR GUARDIAN MAY INITIATE AN APPEAL IN WRITING TO THE SCHOOL PRINCIPAL'S OFFICE WITHIN FIVE (5) SCHOOL DAYS AFTER THE DISCIPLINARY ACTION IS IMPOSED. AN INFORMAL HEARING WILL BE HELD BY THE SCHOOL'S APPEAL COMMITTEE. THE STUDENT AND PARENT/GUARDIAN MUST ATTEND. THE DECISION OF THE APPEAL COMMITTEE SHALL BE FINAL AND SHALL NOT BE SUBJECT TO FURTHER REVIEW.

**REINSTATEMENT**

A STUDENT WHO HAS BEEN SUSPENDED FROM PARTICIPATION IN A CO-CURRICULAR OR EXTRACURRICULAR ACTIVITY MUST APPLY TO THE REINSTATEMENT COMMITTEE. AN APPLICATION MUST BE MADE IN WRITING AND SUBMITTED TO THE SCHOOL PRINCIPAL'S OFFICE. THIS IS THE SOLE RESPONSIBILITY OF THE STUDENT. A HEARING WILL BE HELD THE FOLLOWING MONDAY FOLLOWING THE RECEIPT OF THE APPLICATION FOR REINSTATEMENT. THE DECISION OF THE REINSTATEMENT COMMITTEE SHALL BE FINAL.

\_\_\_\_\_  
STUDENT SIGNATURE

\_\_\_\_\_  
DATE

\_\_\_\_\_  
PARENT/GUARDIAN/CAREGIVER SIGNATURE

\_\_\_\_\_  
DATE

\_\_\_\_\_  
COACH/ADVISOR SIGNATURE

\_\_\_\_\_  
DATE

\_\_\_\_\_  
ATHLETIC/ACTIVITIES DIRECTOR SIGNATURE

\_\_\_\_\_  
DATE

\_\_\_\_\_  
ADMINISTRATOR SIGNATURE

\_\_\_\_\_  
DATE

**CHINO VALLEY UNIFIED SCHOOL DISTRICT**  
EXHIBIT APPROVED:

**Chino Valley Unified School District**

**Our Motto:**

Student Achievement • Safe Schools • Positive School Climate  
Humility • Civility • Service

**DATE:** June 28, 2018  
**TO:** Members, Board of Education  
**FROM:** Wayne M. Joseph, Superintendent  
**PREPARED BY:** Grace Park, Ed.D., Assistant Superintendent, Curriculum, Instruction, Innovation, and Support  
**SUBJECT: REVISION OF BOARD POLICY 6117 INSTRUCTION – YEAR-ROUND SCHEDULES**

=====  
**BACKGROUND**

Board policies, administrative regulations, and bylaws of the Board are routinely developed and revised as a result of changes in law, mandates, federal regulations, and current practice. Board Policy 6117 Instruction – Year-Round Schedules is being updated to clarify that a year-round school is generally required to offer a minimum of 175 instructional days per school year until the district meets or exceeds its funding target under the local control funding formula, at which time the minimum required number of instructional days is 180. Policy adds conditions under which a multitrack year-round school may instead offer a minimum of 163 instructional days. This item was presented to the Board of Education on June 14, 2018, as information.

New language is provided in UPPER CASE while old language to be deleted is ~~lined through~~.

Approval of this item supports the goals identified within the District’s Strategic Plan.

**RECOMMENDATION**

It is recommended the Board of Education approve the revision of Board Policy 6117 Instruction – Year-Round Schedules.

**FISCAL IMPACT**

None.

WMJ:GP:rtr

**YEAR-ROUND SCHEDULES**

The Board of Education believes that a year-round SCHOOL schedule COULD BENEFIT THE DISTRICT AND ITS STUDENTS BY PROVIDING CONTINUOUS INSTRUCTION ~~can~~ AND ~~reducing~~ LEARNING loss ~~of~~ IN studentS ~~learning~~ over EXTENDED vacations, ~~as well as enable the District to address~~ ALLOWING TIMELY INTERVENTIONS TO IMPROVE ACADEMIC ACHIEVEMENT, AND ALLEVIATING overcrowding in schools through ~~the more~~ efficient use of school facilities. The BOARD SHALL CONSIDER THE feasibility of establishing year-round schedules ~~shall be considered as the Board monitors~~ BASED ON current and projected enrollments, facilities needs, and instructional needs.

(cf. 6111 - School Calendar)

(cf. 7110 - Facilities Master Plan)

Before approving a year-round program in any District school, the Board shall consult with certificated and classified employees of the school, parents/guardians of students who would be affected by the change, and the community at large. Such consultation shall include at least one public hearing FOR WHICH ADEQUATE NOTICE HAS BEEN GIVEN TO THE EMPLOYEES AND PARENTS/GUARDIANS OF AFFECTED STUDENTS. (Education Code 37616)

(cf. 0420 - School Plans/Site Councils)

(cf. 4112.9/4212.9/4312.9 - Employee Notifications)

(cf. 5145.6 - Parental Notifications)

(cf. 9320 - Meetings and Notices)

The Superintendent or designee shall develop a year-round schedule for any school selected or approved by the Board for year-round schedule. The schedule shall specify the number of tracks or groups into which students and staff shall be divided and the number and length of instructional and vacation periods.

IF THE BOARD DETERMINES TO OPERATE A YEAR-ROUND PROGRAM IN A MANNER THAT WOULD REQUIRE ANY STUDENT TO ENROLL, THE SUPERINTENDENT OR DESIGNEE SHALL PUBLISH, NOT LATER THAN NOVEMBER 1 OF THE SCHOOL YEAR PRECEDING THE COMMENCEMENT OF THE PROGRAM, NOTICE OF THE DISTRICT'S INTENTION TO OPERATE THE PROGRAM. SUCH NOTICE SHALL BE PUBLISHED IN A NEWSPAPER OF GENERAL CIRCULATION WITHIN THE DISTRICT, OR IF THERE IS NO SUCH NEWSPAPER, THEN IN ANY NEWSPAPER OF GENERAL CIRCULATION THAT IS REGULARLY CIRCULATED IN THE DISTRICT. THE NOTICE SHALL BE PUBLISHED ONCE EACH WEEK FOR THREE SUCCESSIVE WEEKS OR, IF THE NEWSPAPER IS REGULARLY PUBLISHED ONCE A WEEK OR MORE OFTEN, AT LEAST THREE TIMES WITH AT LEAST FIVE DAYS INTERVENING BETWEEN THE RESPECTIVE PUBLICATION DATES NOT COUNTING THE PUBLICATION DATES. (Education Code 37611)

**YEAR-ROUND SCHEDULES (cont.)**

(cf. 5116.1 - Intradistrict Open Enrollment)

ON THE BOARD'S ORDER, OR UPON A SUFFICIENT PETITION BY THE PUBLIC TO THE COUNTY SUPERINTENDENT OF SCHOOLS AFTER THE ABOVE NOTICE OF INTENTION IS GIVEN BY THE DISTRICT, AN ELECTION SHALL BE CALLED TO DETERMINE WHETHER TO PERMIT A YEAR-ROUND PROGRAM TO BE OPERATED. (Education Code 37612)

EACH YEAR-ROUND SCHOOL SHALL OFFER A MINIMUM OF 175 DAYS OF INSTRUCTION PER SCHOOL YEAR, UNTIL IT EQUALS OR EXCEEDS THE LOCAL CONTROL FUNDING FORMULA TARGET ESTABLISHED FOR IT PURSUANT TO EDUCATION CODE 42238.02, AT WHICH TIME EACH SCHOOL SHALL OFFER 180 DAYS OR MORE OF INSTRUCTION PER SCHOOL YEAR. (Education Code 37620, 41420, 46208)

HOWEVER, ANY SCHOOL THAT OPERATES ON A MULTITRACK SCHEDULE SHALL BE DEEMED IN COMPLIANCE WITH THESE REQUIREMENTS IF IT OFFERS A MINIMUM OF 163 INSTRUCTIONAL DAYS PER SCHOOL YEAR. TO DO SO, THE BOARD SHALL ADOPT A RESOLUTION AT A REGULARLY SCHEDULED BOARD MEETING CERTIFYING THAT THE NUMBER OF ANNUAL INSTRUCTIONAL MINUTES IS NOT LESS THAN THAT OF SCHOOLS OF THE SAME GRADE LEVELS UTILIZING THE TRADITIONAL SCHOOL CALENDAR AND THAT IT IS NOT POSSIBLE TO MAINTAIN A MULTITRACK SCHEDULE WITH THE SAME NUMBER OF INSTRUCTIONAL DAYS PROVIDED BY DISTRICT SCHOOLS ON A TRADITIONAL CALENDAR GIVEN THE FACILITIES, PROGRAM, CLASS SIZES, AND PROJECTED NUMBER OF STUDENTS ENROLLED AT THE SCHOOL SITE. THE SUPERINTENDENT OR DESIGNEE SHALL ANNUALLY CERTIFY TO THE SUPERINTENDENT OF PUBLIC INSTRUCTION THAT ANY SUCH SCHOOL IS MAINTAINED FOR AT LEAST 163 INSTRUCTIONAL DAYS. (Education Code 37670, 46208)

(cf. 1431 - Waivers)  
(cf. 6112 - School Day)

EACH SCHOOL OPERATING ON A YEAR-ROUND SCHEDULE SHALL BE CLOSED FOR ALL STUDENTS AND EMPLOYEES ON REGULAR SCHOOL HOLIDAYS. (Education Code 37619)

(cf. 6115 - Ceremonies and Observances)

**Assignment to Year-Round Tracks**

The Superintendent or designee shall establish an unbiased process for determining assignment of students to tracks based on the following ~~criteria~~ GUIDELINES:

**YEAR-ROUND SCHEDULES (cont.)**

1. Students of the same family shall be placed in the same group or track unless one or more of such students are enrolled in a special education class or unless the parent/guardian requests that the students be placed in different groups. (Education Code 37617)

(cf. 6159 - Individualized Education Program)

2. Assignment based on ability level shall be minimized except when necessary to accommodate special education needs or other specialized programs.

(cf. 6159 - Individualized Education Program)

(cf. 6172 - Gifted and Talented Student Program)

3. ~~After assignment based on the above priorities, remaining s~~Students shall be chosen on a lottery basis when the number of students requesting a particular track exceeds spaces available. ~~STUDENTS' Ssecond preferences~~ CHOICES OF TRACK ASSIGNMENT shall be accommodated to the extent possible.

The Superintendent or designee shall give parents/guardians adequate notice regarding their child's schedule.

Once students are assigned to a track, priority shall be placed on keeping students on the same track each year unless the parent/guardian requests a change.

**Legal Reference:****EDUCATION CODE**

17017.5 Approval of Applications; Year-Round Education Program

17017.6 Substantial Enrollment, High School Districts

17017.7 Priority for Funding New Construction

17071.40 Exemption from Increase in School Building Capacity

17088.3 Qualifications for Lease; Submission of Year-Round Multi-track Educational Program Study

37202 Equity Length of Term, Exceptions

37220-37223 Saturdays and Holidays

37600-37644 Continuous School Programs

37670-37672 Multi-track Year-Round Scheduling

37693 Concept 6 program elimination

41420 Minimum Number of Instructional Days Per Year

42238.02 Local control funding formula

42250.1 Funding for Air Conditioning

46200-46206 Incentives for Longer Instructional Day and Year

**CODE OF REGULATIONS, TITLE 5**

855 Testing Period

14030 School Housing Standards for Multi-track Programs

**Management Resources:****CALIFORNIA DEPARTMENT OF EDUCATION PUBLICATIONS**

Year-Round Education Program Guide

**YEAR-ROUND SCHEDULES (cont.)**

WEBSITES

California Department of Education, Multi-track Year-Round Education: [www.cde.ca.gov/ls/fa/yr](http://www.cde.ca.gov/ls/fa/yr)  
National Association for Year-Round Education: [www.nayre.org](http://www.nayre.org)

**Chino Valley Unified School District**

Policy adopted: August 21, 1997

Revised: June 18, 2009

REVISED:

**CHINO VALLEY UNIFIED SCHOOL DISTRICT**

**Our Motto:**

Student Achievement • Safe Schools • Positive School Climate  
Humility • Civility • Service

**DATE:** June 28, 2018  
**TO:** Members, Board of Education  
**FROM:** Wayne M. Joseph, Superintendent  
**PREPARED BY:** Gregory J. Stachura, Asst. Supt., Facilities, Planning, and Operations  
Anna G. Hamilton, Director, Purchasing  
**SUBJECT: PURCHASE ORDER REGISTER**

=====

**BACKGROUND**

Board Policy 3310 Business and Noninstructional Operations – Purchasing requires approval/ratification of purchase orders by the Board of Education. A purchase order is a legal contract between a district and vendor, containing a description of each item listed and/or a statement to the effect that supplies, equipment or services furnished herewith shall be in accordance with specifications and conditions.

Purchase orders represent a commitment of funds. No item on this register will be processed unless within budgeted funds. The actual payment for the services or materials is made with a warrant (check) and reported on the warrant register report.

Approval of this item supports the goals identified within the District’s Strategic Plan.

**RECOMMENDATION**

It is recommended the Board of Education approve/ratify the purchase order register, provided under separate cover.

**FISCAL IMPACT**

\$4,985,748.55 to all District funding sources.

WMJ:GJS:AGH:pw



**CHINO VALLEY UNIFIED SCHOOL DISTRICT**

**Our Motto:**

Student Achievement • Safe Schools • Positive School Climate  
Humility • Civility • Service

**DATE:** June 28, 2018  
**TO:** Members, Board of Education  
**FROM:** Wayne M. Joseph, Superintendent  
**PREPARED BY:** Gregory J. Stachura, Asst. Supt., Facilities, Planning, and Operations  
Anna G. Hamilton, Director, Purchasing  
**SUBJECT: AGREEMENTS FOR CONTRACTOR/CONSULTANT SERVICES**

=====

**BACKGROUND**

All contracts between the District and outside agencies shall conform to standards required by law and shall be prepared under the direction of the Superintendent or designee. To be valid or to constitute an enforceable obligation against the District, all contracts must be approved and/or ratified by the Board of Education.

Approval of this item supports the goals identified within the District's Strategic Plan.

**RECOMMENDATION**

It is recommended the Board of Education approve/ratify the Agreements for Contractor/Consultant Services.

**FISCAL IMPACT**

As indicated.

WMJ:GJS:AGH:pw

<b>SUPERINTENDENT</b>	<b>FISCAL IMPACT</b>
<b>S-1819-003 Atkinson, Andelson, Loya, Ruud &amp; Romo.</b> To provide legal services. Submitted by: Superintendent Duration of Agreement: July 1, 2018 - June 30, 2019	Contract amount: Per rate sheet  Funding source: Various

<b>BUSINESS SERVICES</b>	<b>FISCAL IMPACT</b>
<b>B-1819-006 EMS LINQ Inc.</b> To provide School Nutrition and Fitness website annual renewal. Submitted by: Nutrition Services Duration of Agreement: July 1, 2018 - June 30, 2018	Contract amount: \$695.00  Funding source: Cafeteria Fund

<b>CURRICULUM, INSTRUCTION, INNOVATION, AND SUPPORT</b>	<b>FISCAL IMPACT</b>
<b>CIIS-1819-036 MCA Sa He Le Lodge.</b> To provide lodge rental for Chino HS cross country team. Submitted by: Chino HS Duration of Agreement: July 1, 2018 – August 31, 2018	Contract amount: \$800.00  Funding source: Fundraisers
<b>CIIS-1819-040 NJA Therapy Service.</b> To provide occupational therapy services. Submitted by: Special Education Duration of Agreement: July 1, 2018 – June 30, 2019	Contract amount: Per rate sheet  Funding source: Special Education
<b>CIIS-1819-041 Zenith Rehabilitation.</b> To provide speech/language pathology services. Submitted by: Special Education Duration of Agreement: July 1, 2018 – June 30, 2019	Contract amount: Per rate sheet  Funding source: Special Education
<b>CIIS-1819-042 American Logistics Company, LLC.</b> To provide alternative student transportation services. Submitted by: Special Education Duration of Agreement: July 1, 2018 – June 30, 2019	Contract amount: Per rate sheet  Funding source: Special Education
<b>CIIS-1819-043 Pacific Coast Speech.</b> To provide speech/language therapy services. Submitted by: Special Education Duration of Agreement: July 1, 2018 – June 30, 2019	Contract amount: Per rate sheet  Funding source: Special Education
<b>CIIS-1819-044 Communicaide Inc.</b> To provide interpreters, translation and American Sign Language (ASL) services. Submitted by: Special Education Duration of Agreement: July 1, 2018 – June 30, 2019	Contract amount: Per rate sheet  Funding source: Special Education
<b>CIIS-1819-045 SecureTransportation.</b> To provide alternative home-to-school homeless student transportation services. Submitted by: Health Services Duration of Agreement: July 1, 2018 – June 30, 2019	Contract amount: Per rate sheet  Funding source: Title 1
<b>CIIS-1819-046 Extensive Therapy.</b> To provide speech/language therapy services. Submitted by: Special Education Duration of Agreement: July 1, 2018 – June 30, 2019	Contract amount: Per rate sheet  Funding source: Special Education
<b>CIIS-1819-047 Pristine Rehab Care.</b> To provide occupational therapy and speech/language pathology services. Submitted by: Special Education Duration of Agreement: July 1, 2018 – June 30, 2019	Contract amount: Per rate sheet  Funding source: Special Education

CURRICULUM, INSTRUCTION, INNOVATION, AND SUPPORT	FISCAL IMPACT
<p><b>CIIS-1819-048 Russo, Fleck &amp; Associates.</b>            To provide occupational therapy services.            Submitted by: Special Education            Duration of Agreement: July 1, 2018 – June 30, 2019</p>	<p>Contract amount: Per rate sheet            Funding source: Special Education</p>
<p><b>CIIS-1819-049 Patrice Toyota DBA Speak Up.</b>            To provide speech/language therapy services.            Submitted by: Special Education            Duration of Agreement: July 1, 2018 – June 30, 2019</p>	<p>Contract amount: Per rate sheet            Funding source: Special Education</p>
<p><b>CIIS-1819-050 Therapy Mantra, Inc.</b>            To provide speech/language therapy services.            Submitted by: Special Education            Duration of Agreement: July 1, 2018 – June 30, 2019</p>	<p>Contract amount: Per rate sheet            Funding source: Special Education</p>
<p><b>CIIS-1819-051 Ukes Communication Services, Inc.</b>            To provide speech/language therapy services.            Submitted by: Special Education            Duration of Agreement: July 1, 2018 – June 30, 2019</p>	<p>Contract amount: Per rate sheet            Funding source: Special Education</p>
<p><b>CIIS-1819-052 VNA Private Duty Care.</b>            To provide nursing services.            Submitted by: Special Education            Duration of Agreement: July 1, 2018 – June 30, 2019</p>	<p>Contract amount: Per rate sheet            Funding source: Special Education</p>
<p><b>CIIS-1819-053 GT Soft Inc.</b>            To provide web-based attendance/billing tracking for child care programs.            Submitted by: Health Services/Child Development            Duration of Agreement: July 1, 2018 – June 30, 2019</p>	<p>Contract amount: Per rate sheet            Funding source: Health Services/Child Development</p>
<p><b>CIIS-1819-054 City of Chino.</b>            To provide outreach specialist for the CVUSD Health Center.            Submitted by: Health Services            Duration of Agreement: July 1, 2018 – June 30, 2019</p>	<p>Contract amount: \$57,366.00            Funding source: LCAP</p>
<p><b>CIIS-1819-055 California Department of Education.</b>            To provide agreement with the state to operate the State Preschool program.            Submitted by: Child Development            Duration of Agreement: July 1, 2018 – June 30, 2019</p>	<p>Contract amount: \$283,846.00            Funding source: Child Development</p>
<p><b>CIIS-1819-056 California Department of Education.</b>            To provide agreement with the state to operate the general Child Care and Development programs.            Submitted by: Child Development            Duration of Agreement: July 1, 2018 – June 30, 2019</p>	<p>Contract amount: \$538,373.00            Funding source: Child Development</p>
<p><b>CIIS-1819-057 Susanne Montgomery.</b>            To provide consultant/evaluation services for the TUPE grant.            Submitted by: Health Services            Duration of Agreement: July 1, 2018 – June 30, 2019</p>	<p>Contract amount: \$25,000.00            Funding source: TUPE Grant</p>
<p><b>CIIS-1819-058 Ray Lozano dba Prevention Plus.</b>            To provide professional speaking presentations.            Submitted by: Health Services            Duration of Agreement: July 1, 2018 – June 30, 2019</p>	<p>Contract amount: \$25,000.00            Funding source: TUPE Grant</p>
<p><b>CIIS-1819-059 City of Chino.</b>            To provide Tobacco Use Prevention Education (TUPE) grant services.            Submitted by: Health Services            Duration of Agreement: July 1, 2018 – June 30, 2019</p>	<p>Contract amount: \$58,000.00            Funding source: TUPE Grant</p>

<b>CURRICULUM, INSTRUCTION, INNOVATION, AND SUPPORT</b>	<b>FISCAL IMPACT</b>
<p><b>CIIS-1819-060 City of Chino.</b>            To provide case management, counseling and family support services for the HOPE Program.            Submitted by: Health Services            Duration of Agreement: July 1, 2018 – June 30, 2019</p>	<p>Contract amount: \$430,000.00             Funding source: LCAP</p>
<p><b>CIIS-1819-061 City of Chino.</b>            To provide case management support services for the homeless and unaccompanied youth for the EXCEL program.            Submitted by: Health Services            Duration of Agreement: July 1, 2018 – June 30, 2019</p>	<p>Contract amount: \$19,000.00             Funding source: IEUW Grant</p>
<p><b>CIIS-1819-062 City of Chino.</b>            To provide school-based counseling and health services for CVUSD students.            Submitted by: Health Services            Duration of Agreement: July 1, 2018 – June 30, 2019</p>	<p>Contract amount: \$85,000.00             Funding source: LEA</p>
<p><b>CIIS-1819-063 City of Chino.</b>            To provide parenting education and case management support services for TYKES.            Submitted by: Health Services            Duration of Agreement: July 1, 2018 – June 30, 2019</p>	<p>Contract amount: \$105,500.00             Funding source: First 5 San Bernardino</p>
<p><b>CIIS-1819-064 Thomaskelly Software Associates, LP.</b>            To provide on-line attendance tracking for the afterschool program.            Submitted by: Health Services            Duration of Agreement: July 1, 2018 – June 30, 2019</p>	<p>Contract amount: \$5,800.00             Funding source: ASES Grant</p>
<p><b>CIIS-1819-065 City of Chino.</b>            To provide staffing for after school programs.            Submitted by: Health Services            Duration of Agreement: July 1, 2018 – June 30, 2019</p>	<p>Contract amount: \$508,777.08             Funding source: ASES Grant</p>
<p><b>CIIS-1819-066 City of Chino.</b>            To provide counseling services for homeless students and unaccompanied youth for the CARE program.            Submitted by: Health Services            Duration of Agreement: July 1, 2018 – June 30, 2019</p>	<p>Contract amount: \$20,000.00             Funding source: Title 1</p>
<p><b>CIIS-1819-067 Committee for Children.</b>            To provide on-line social and emotional curriculum for Multi-tiered School System Behavior Intervention counseling.            Submitted by: Health Services            Duration of Agreement: July 1, 2018 – June 30, 2019</p>	<p>Contract amount: \$2,499.00             Funding source: LCAP</p>
<p><b>CIIS-1819-068 Achilles Bardos dba Edumetrisis LLC.</b>            To provide progress monitoring for Multi-tiered School System Behavior Intervention counselors.            Submitted by: Health Services            Duration of Agreement: July 1, 2018 – June 30, 2019</p>	<p>Contract amount: \$900.00             Funding source: LCAP</p>
<p><b>CIIS-1819-069 Studentnest Inc. dba Studentnest.com.</b>            To provide math and English language arts tutoring services for the CARE Program.            Submitted by: Health Services            Duration of Agreement: July 1, 2018 – June 30, 2019</p>	<p>Contract amount: \$75,000.00             Funding source: LCAP &amp; Title 1</p>

CURRICULUM, INSTRUCTION, INNOVATION, AND SUPPORT	FISCAL IMPACT
<p><b>CIIS-1819-070 CDW-G.</b>            To provide ContentKeeper web filter software, licensing, and services.            Submitted by: Technology            Duration of Agreement: July 1, 2018 – June 30, 2019</p>	<p>Contract amount: \$203,852.53            Funding source: LCAP</p>
<p><b>CIIS-1819-071 Judith Aguilera dba Beyond Words Speech-Language Pathology Service, Inc.</b>            To provide speech/language pathology services.            Submitted by: Special Education            Duration of Agreement: July 1, 2018 - June 30, 2019</p>	<p>Contract amount: \$100,000.00            Funding source: Special Education</p>
<p><b>CIIS-1819-072 Achilles Bardos dba Edumetrisis LLC.</b>            To provide behavior intervention monitoring system.            Submitted by: Special Education            Duration of Agreement: July 1, 2018 - June 30, 2019</p>	<p>Contract amount: Per rate sheet            Funding source: Special Education</p>
<p><b>CIIS-1819-073 Psychological Assessment Resources, Inc dba PAR, Inc.</b>            To provide online psychological assessments and scoring.            Submitted by: Special Education            Duration of Agreement: July 1, 2018 - June 30, 2019</p>	<p>Contract amount: Per rate sheet            Funding source: Special Education</p>
<p><b>CIIS-1819-074 NCS Pearson, Inc.</b>            To provide academic and psychological assessment and scoring.            Submitted by: Special Education            Duration of Agreement: July 1, 2018 - June 30, 2019</p>	<p>Contract amount: Per rate sheet            Funding source: Special Education</p>
<p><b>CIIS-1819-075 MHS Inc.</b>            To provide online protocols and scoring.            Submitted by: Special Education            Duration of Agreement: July 1, 2018 - June 30, 2019</p>	<p>Contract amount: \$15,000.00            Funding source: Special Education</p>
<p><b>CIIS-1819-076 Crisis Prevention Institute, Inc.</b>            To provide non-violent crisis prevention training.            Submitted by: Special Education            Duration of Agreement: July 1, 2018 - June 30, 2019</p>	<p>Contract amount: \$2,500.00            Funding source: Special Education</p>
<p><b>CIIS-1819-077 Brain Train, Inc.</b>            To provide intergrated visual auditory assessments.            Submitted by: Special Education            Duration of Agreement: July 1, 2018 - June 30, 2019</p>	<p>Contract amount: \$8,000.00            Funding source: Special Education</p>
<p><b>CIIS-1819-078 Houghton Mifflin Harcourt Publishing Co.</b>            To provide Woodcock-Johnson IV on-line scoring cognitive tests.            Submitted by: Special Education            Duration of Agreement: July 1, 2018 - June 30, 2019</p>	<p>Contract amount: \$15,000.00            Funding source: Special Education</p>
<p><b>CIIS-1819-079 Athena Software.</b>            To provide web-based case management system.            Submitted by: Special Education and Health Services            Duration of Agreement: July 1, 2018 - June 30, 2019</p>	<p>Contract amount: Per rate sheet            Funding source: Various</p>
<p><b>CIIS-1819-080 SHI.</b>            To provide server licenses.            Submitted by: Technology            Duration of Agreement: July 1, 2018 – June 30, 2019</p>	<p>Contract amount: \$14,787.60            Funding source: LCAP</p>

<b>HUMAN RESOURCES</b>	<b>FISCAL IMPACT</b>
<b>HR-1819-003 City of Chino.</b> To provide school resource officers for Magnolia JHS, Ramona JHS, Buena Vista HS, Chino HS, and Don Lugo HS Submitted by: Human Resources Duration of Agreement: July 1, 2018 - June 30, 2019	Contract amount: \$364,361.00  Funding source: General Fund

<b>MASTER CONTRACTS</b>	<b>FISCAL IMPACT</b>
<b>MC-1819-007 Juice It Up.</b> To provide catering services. Submitted by: Purchasing Duration of Agreement: July 1, 2018 - June 30, 2021	Contract amount: Per rate sheet  Funding source: ASB
<b>MC-1819-008 Josten's.</b> To provide rings and graduation supplies. Submitted by: Don Lugo HS Duration of Agreement: July 1, 2018 - June 30, 2021	Contract amount: Per rate sheet  Funding source: ASB
<b>MC-1819-009 Balloon Haven.</b> To provide helium and balloon supplies for events. Submitted by: Don Lugo HS Duration of Agreement: July 1, 2018 - June 30, 2021	Contract amount: Per rate sheet  Funding source: ASB
<b>MC-1819-010 Real Inspiration, Inc.</b> To provide motivational speaker for assemblies and events. Submitted by: Don Lugo HS Duration of Agreement: July 1, 2018 - June 30, 2021	Contract amount: Per rate sheet  Funding source: ASB
<b>MC-1819-011 Nicky's Phillys.</b> To provide catering services. Submitted by: Purchasing Duration of Agreement: July 1, 2018 - June 30, 2021	Contract amount: Per rate sheet  Funding source: Fundraisers

<b>APPROVED CONTRACTS TO BE AMENDED</b>	<b>AMENDMENT</b>
<b>CIIS-1718-026 Pristine Rehab Care LLC.</b> To provide speech, language, and occupational therapy services. Duration of Agreement: July 1, 2017 – June 30, 2018 Original Agreement Board Approved: June 29, 2017	Increase contract amount from \$599,500.00 to \$779,500.00  Funding source: Special Education
<b>CIIS-1718-028 Illuminate Education Inc.</b> To provide data and assessment K-12 and Key data systems 7-12. Submitted by: Assessment and Instructional Technology Duration of Agreement: July 1, 2017 – June 30, 2018 Original Agreement Board Approved: June 29, 2017	Increase contract amount from \$151,207.50 to \$453,622.50  Duration of agreement: July 1, 2017 – June 30, 2020  Funding source: General Fund
<b>F-1718-021 Raptor Technologies.</b> To provide school site visitor management system. Submitted by: Purchasing Duration of Agreement: January 19, 2018 – December 31, 2019 Original Agreement Board Approved: February 15, 2018	Increase contract amount from \$51,200.00 to \$57,600.00  Funding source: Fund 21

**CHINO VALLEY UNIFIED SCHOOL DISTRICT**

**Our Motto:**

Student Achievement • Safe Schools • Positive School Climate  
Humility • Civility • Service

**DATE:** June 28, 2018  
**TO:** Members, Board of Education  
**FROM:** Wayne M. Joseph, Superintendent  
**PREPARED BY:** Gregory J. Stachura, Asst. Supt., Facilities, Planning, and Operations  
**SUBJECT: SURPLUS/OBSOLETE PROPERTY**

=====

**BACKGROUND**

The Board of Education recognizes that the District may own personal property which is unusable, obsolete, or no longer needed by the District. The Superintendent or designee shall arrange for the sale or disposal of District personal property in accordance with Board policy and the requirements of Education Code 17545.

Lists of surplus items are emailed to the Facilities/Planning Department to be placed on an upcoming Board agenda. After Board approval, items may be picked up by District warehouse or a liquidation company for public auction. Proceeds of the sale are deposited into the General Fund.

Approval of this item supports the goals identified within the District's Strategic Plan.

**RECOMMENDATION**

It is recommended the Board of Education declare the District property surplus/obsolete and authorize staff to sell/dispose of said property.

**FISCAL IMPACT**

Increase to the General Fund from proceeds of sale.

WMJ:GJS:pw

**CHINO VALLEY UNIFIED SCHOOL DISTRICT  
SURPLUS/OBSOLETE PROPERTY**

June 28, 2018

<u>DESCRIPTION</u>	<u>MAKE/MODEL</u>	<u>I.D./SERIAL</u>	<u>DEPT/SITE</u>
Modem	Dell	CVUA RM 34-03	CVLA
Modem	Dell	504 TCH 6GHLFB2	CVLA
Modem	Sony		CVLA
Printer HP	Pro 400 Color M451dn	CNDF254233	Human Resources
Computer	Dell	OptiPlex 780	Cattle ES
Computer	Dell	OptiPlex 780	Cattle ES
Computer	Dell	OptiPlex 780	Cattle ES
Computer	Dell	OptiPlex 745	Cattle ES
Computer	Dell	OptiPlex 745	Cattle ES
Computer	Dell	OptiPlex GX520	Cattle ES
TV	Zenith		Cattle ES
TV	Samsung		Cattle ES
VCR	Sharp		Cattle ES
Printer	Xerox	NKA118297	Country Springs ES
Printer	Xerox	NKA118219	Country Springs ES
Printer	Xerox	NKA119463	Country Springs ES
Printer	Xerox	NKA119469	Country Springs ES
Printer	Xerox	NKA119463	Country Springs ES
Printer	Xerox	NKA118220	Country Springs ES
Printer	Xerox	NKA119439	Country Springs ES
Responders	Renaissance	6077A-REC1001	Country Springs ES
Responders	Renaissance	6077A-REC1001	Country Springs ES
Responders	Renaissance	6077A-REC1001	Country Springs ES
Laptop	Dell	HF6FWD1	Country Springs ES
Laptop	Dell	6F30XK1	Country Springs ES
Laptop	Dell	4K5X9KI	Country Springs ES
Laptop	Dell	F263VK1	Country Springs ES
Laptop	Dell	JCOMCI	Country Springs ES
Laptop	Aspire	LXAS505237516070D6EMOO	Country Springs ES
MimioPad	Dymo	919HM110703052	Country Springs ES
MimioPad	Dymo	919HM110702955	Country Springs ES
DVD/VCR Player	Magnavox	U15688734	Country Springs ES
Responders	Renaissance	6077A-REC1001	Country Springs ES
Projector Camera	Aver Media	51770 09030P	Country Springs ES
Computer tower	Dell	34467	Dickey ES
Computer tower	Dell	32577	Dickey ES
Computer tower	Dell	34459	Dickey ES
Computer tower	Dell	D32KSC1	Dickey ES



<u>DESCRIPTION</u>	<u>MAKE/MODEL</u>	<u>I.D./SERIAL</u>	<u>DEPT/SITE</u>
Computer tower	Dell	310-RM136-STU03	Dickey ES
Computer tower	Dell	33053	Dickey ES
Computer tower	Dell	310-RM137-C	Dickey ES
Computer tower	Dell	310-RM101-STU07	Dickey ES
Computer tower	Dell	310-RM101-STU05	Dickey ES
Computer tower	Dell	80045-510-134-685	Dickey ES
Computer tower	Dell	310-RM101-STU03	Dickey ES
Computer tower	Dell	80045-510-134-689	Dickey ES
Computer tower	Dell	80045-510-134-693	Dickey ES
Computer tower	Dell	55692	Dickey ES
Monitor	Dell	CN0C730C716230711322	Dickey ES
Monitor	Dell	CN0WH3187287272C2YYI	Dickey ES
Monitor	Dell	CN0C730C7162302N1673	Dickey ES
Keyboard	Dell	Cn0dj3317161608n0ec0	Dickey ES
Keyboard	Dell	Cn0rh6597357107800w6	Dickey ES
Keyboard	Dell	Cn0u473d447519370171a00	Dickey ES
Keyboard	Dell	Cn0rh6597357178201hi	Dickey ES
Keyboard	Dell	CN0RH6597357171782087U	Dickey ES
Keyboard	Dell	CN0RH65973571778201JB	Dickey ES
Keyboard	Dell	CN0RH6597357177820827	Dickey ES
Keyboard	Dell	CN0RH659735717782041Q	Dickey ES
Keyboard	Dell	CN0RH65973571707I-0625	Dickey ES
Keyboard	Dell	CN0RH65973571778208BS	Dickey ES
Keyboard	Dell	CN04G481716164AN08SXA00	Dickey ES
Keyboard	Dell	CN04473D447519370162A00	Dickey ES
Mouse	Dell	I1400A1Y	Dickey ES
Mouse	Dell	CN09RRC74475107801CE	Dickey ES
Mouse	Dell	11400A5S	Dickey ES
Mouse	Dell	G0S01FT1	Dickey ES
Mouse	Dell	G0S01FVL	Dickey ES
Mouse	Dell	G0S01D7R	Dickey ES
Mouse	Dell	G0S01HNP	Dickey ES
Mouse	Dell	G0S01GQN	Dickey ES
Mouse	Dell	G0V00QVA	Dickey ES
TV	Sharp	33307	Dickson ES
TV	Sharp	33295	Dickson ES
TV	Sharp	A27039	Dickson ES
TV	Sharp	33304	Dickson ES
TV	Sharp	33311	Dickson ES
TV	Sharp	33297	Dickson ES
TV	Sharp	32237	Dickson ES
TV	Sharp	33309	Dickson ES

<u>DESCRIPTION</u>	<u>MAKE/MODEL</u>	<u>I.D./SERIAL</u>	<u>DEPT/SITE</u>
TV	Sharp	32004	Dickson ES
TV	Sharp	30359	Dickson ES
TV	Sharp	33310	Dickson ES
TV	Sharp	33306	Dickson ES
TV	Sharp	33302	Dickson ES
TV	Sharp	33300	Dickson ES
TV	Sharp	30670	Dickson ES
TV	Sharp	C07026	Dickson ES
TV	Sharp	G8971321	Dickson ES
TV	Sharp	C07028	Dickson ES
TV	Sharp	C07025	Dickson ES
TV	Sharp	30669	Dickson ES
TV	Sharp	30360	Dickson ES
Laptop	Apple		Dickson ES
Laptop	Dell	E2KWM3945ABG	Dickson ES
Rolling Cabinet		03890	Dickson ES
Student Desks (37)			Dickson ES
Teacher Desk		105815	Dickson ES
Rolling Chairs (19)			Dickson ES
Chairs (11)			Dickson ES
Rolling Book Shelf		AOS783	Dickson ES
Rolling Cabinet			Dickson ES
Metal Cabinets (3)		A10989	Dickson ES
Rolling Cabinet		03943	Dickson ES
Metal Cabinet			Dickson ES
Teacher Desk		AOS827	Dickson ES
Teacher Desk		A06085	Dickson ES
Teacher Podium		A14210	Dickson ES
Teacher Desk		A06068	Dickson ES
Rectangle Tables (3)			Dickson ES
Kidney Table			Dickson ES
Electronic Keyboard	Yamaha	UBOX01448	Dickson ES
Electronic Keyboard	Yamaha	UBOX01436	Dickson ES
Electronic Keyboard	Yamaha	UBOX01443	Dickson ES
Electronic Keyboard	Yamaha	UBOX01417	Dickson ES
Electronic Keyboard	Yamaha	UBOX01424	Dickson ES
Electronic Keyboard	Yamaha	UBOX01423	Dickson ES
Electronic Keyboard	Yamaha	UBOX01430	Dickson ES
Electronic Keyboard	Yamaha	UBOX01429	Dickson ES
Electronic Keyboard	Yamaha	UBOX01416	Dickson ES
Electronic Keyboard	Yamaha	UBOX01420	Dickson ES
Electronic Keyboard	Yamaha	UBOX01434	Dickson ES

<u>DESCRIPTION</u>	<u>MAKE/MODEL</u>	<u>I.D./SERIAL</u>	<u>DEPT/SITE</u>
Electronic Keyboard	Yamaha	UBOX01444	Dickson ES
Electronic Keyboard	Yamaha	UBOX01445	Dickson ES
Electronic Keyboard	Yamaha	UBOX01431	Dickson ES
Electronic Keyboard	Yamaha	UBOX01422	Dickson ES
Electronic Keyboard	Yamaha	UBOX01426	Dickson ES
Headphones (6 cases)	School Smart		Dickson ES
Video Camera	Sony	424037	Dickson ES
Video Camera	Sony	421762	Dickson ES
Video Camera	Sony	1357767	Dickson ES
Video Camera	Sony	421753	Dickson ES
Video Camera	Sony	416328	Dickson ES
Camera	Olympus	CN42CD04PS	Dickson ES
Keyboard Stands (4)		PKBSI	Dickson ES
Keyboard Benches (24)		PKBBI	Dickson ES
Piano	Wurlitzer	1509324	Dickson ES
Piano	Wurlitzer	1523435	Dickson ES
Electronic Keyboard	Yamaha	UBMB2667	Dickson ES
Electronic Keyboard	Casio	CTK-611	Dickson ES
Headphones	Califone		Dickson ES
Computer Tower	Dell	F8J30F1	Dickson ES
DVD Player	Daewoo	48J02908	Dickson ES
Computer Tower	Dell	H3TBSC1	Dickson ES
Printer	HP	03718	Dickson ES
CO Player	Emerson	62308131	Dickson ES
VHS Player	Panasonic	AGMA24003	Dickson ES
CD Radio Player	School Start	BK-10522	Dickson ES
Cassette Recorder	Califone	E1250659	Dickson ES
Cassette Recorder	Califone	E1250739	Dickson ES
Cassette Recorder	Califone	AJ492254	Dickson ES
Cassette Recorder	School Mate	00030274-1807	Dickson ES
CO Radio Player	School Mate	SC-5050	Dickson ES
CO Radio Player	School Start	BX-103A	Dickson ES
CO/Aux Radio Player	Coby	CXCD275	Dickson ES
CD/Cassette Radio Player	Califone	AH00636	Dickson ES
Printer	HP	MX07V1COVS	Dickson ES
Karaoke Machine	Memorex	028710201360	Dickson ES
Keyboard	Dell	E145614	Dickson ES
Overhead Projector	3M	170041691	Dickson ES
Overhead Projector	3M	170041670	Dickson ES
Overhead Projector	3M	170041682	Dickson ES
Laptop	Apple	A1181	Dickson ES
Metal File Cabinet		A05819	Dickson ES

<u>DESCRIPTION</u>	<u>MAKE/MODEL</u>	<u>I.D./SERIAL</u>	<u>DEPT/SITE</u>
Keyboard	HP	ONORH659735 7107K084VG	Glenmeade ES
Projector	Epson H454A	QOXF2S1138L	Glenmeade ES
Monitor	HANS-G	242AA3WY01283	Glenmeade ES
Projector	ELMO IT-02	90272624593	Glenmeade ES
Laptop	Dell E5400	12066067945	Glenmeade ES
Laptop	Dell ES400	338338913055	Glenmeade ES
Laptop	Dell E5400	800-45409121	Glenmeade ES
Battery	HP	C1459AQDF002L	Glenmeade ES
Printer	HP 4050N	05814	Glenmeade ES
Printer	HP 7410Xi	MY63MP7126	Glenmeade ES
Printer	HP P1606dn	VNB3L60800	Glenmeade ES
Keyboard	HP PR11014	BCYRVOA4H6B61R	Glenmeade ES
Keyboard	Dell KB212-B	04G48171616	Glenmeade ES
Monitor	Dell P1917S	SCRFN2	Glenmeade ES
Projector	ELMO TP-02	902706	Glenmeade ES
Printer	HP Laser Jet 1300	CNBB106206	Glenmeade ES
Projector	Epson 83T	KM3F826141L	Glenmeade ES
Atemsi m-Media	300AFT	5255908040P	Glenmeade ES
Projector	Epson 82C	GY8GG30197F	Glenmeade ES
Projector	Epson 100-240V	KM3F8252G52	Glenmeade ES
Projector	NEC VT47	\$X00331UH	Glenmeade ES
Keyboard	Dell SK8115	ODJ3317161681B01334	Glenmeade ES
Keyboard	Dell LIOO	ORH659735716C404LC	Glenmeade ES
Projector	Epson 83T	KM3F9601342	Glenmeade ES
Projector	Epson 3LCD	KM3F9328482	Glenmeade ES
Projector	ELMO JT-02	902703	Glenmeade ES
Projector	ELMO IT-02	902704	Glenmeade ES
Projector	Epson EMP-53	EYM0340123K	Glenmeade ES
DVD Player	Cali Fone	100/601ME000419	Glenmeade ES
DVD Player	Samsung V9800	B60B6CC5329106N	Glenmeade ES
Keyboard	HP SK2025	572647-003	Glenmeade ES
I-Book	G4 A1005		Glenmeade ES
I-Book	G4-A1005		Glenmeade ES
I-Book	G4-A1005		Glenmeade ES
Laptop	Dell E5440	12058682582	Glenmeade ES
DVD Player	Samsung V9800	B60686CCS329125K	Glenmeade ES
Laptop	Dell E5440	1922664057	Glenmeade ES
CPU	Optiplex 755	70045462092199	Glenmeade ES
CPU	Dell	00045642035822	Glenmeade ES
Projector	Epson 83T	KM3F825404L	Glenmeade ES
Lightspeed AMP	8ZoiR	RX8201006110549	Glenmeade ES
Projector	Epson 83TT	KM3F8253986	Glenmeade ES

<u>DESCRIPTION</u>	<u>MAKE/MODEL</u>	<u>I.D./SERIAL</u>	<u>DEPT/SITE</u>
Projector	Epson 83T	KM3F900143L	Glenmeade ES
Laptop	Dell 3450	28663740938	Glenmeade ES
Laptop	Dell 0336	800 409121943	Glenmeade ES
Bookcases (4)			Hidden Trails ES
File Cabinets			Hidden Trails ES
TV	Sharp	A27599	Hidden Trails ES
Typewriter	Brothers	K48174487	Hidden Trails ES
Kidney Table			Hidden Trails ES
Kidney Table – 6’			Hidden Trails ES
Kidney Table – 5’			Hidden Trails ES
Rolling Cabinets (11)	Brown		Hidden Trails ES
Rolling Cabinets (3)	Pink		Hidden Trails ES
Teacher Desks (12)			Hidden Trails ES
Student Desks (200)			Hidden Trails ES
Electric Roll Carts (4)			Hidden Trails ES
Projector Roll Carts (5)			Hidden Trails ES
Roll Carts Pink (2)			Hidden Trails ES
Roll Carts Brown (2)			Hidden Trails ES
Printer	HP 4700N	22342	Hidden Trails ES
Cassette Recorder	Califone	A29258	Hidden Trails ES
Projector	Smart	B012CB25A0777	Hidden Trails ES
Projector	Smart	B012CB25A0809	Hidden Trails ES
Projector	Smart	B012CB25A0880	Hidden Trails ES
Projector	Smart	B012CB25A0782	Hidden Trails ES
Projector	Smart	B012CB25A0776	Hidden Trails ES
Projector	Smart	B012CB25A0770	Hidden Trails ES
Projector	Smart	B012BE2400257	Hidden Trails ES
Projector	Smart	B012BC2600224	Hidden Trails ES
Computer	Dell	GCCPPD1	Oak Ridge ES
Computer	Dell	5SCCMB1	Oak Ridge ES
Printer	Xerox	CAT389562	Oak Ridge ES
Printer	Xerox	YGG991322	Oak Ridge ES
Printer	Xerox	CAT389590	Oak Ridge ES
Printer	Xerox	CAT389595	Oak Ridge ES
Printer	HP	CVUSD 16210	Oak Ridge ES
Printer	HP	VND3B33389	Oak Ridge ES
Printer	HP	CVUSD 35962	Oak Ridge ES
DVD	Panasonic	VA50B008777	Oak Ridge ES
DVD	Philips	KT060047071566	Oak Ridge ES
Printer	Phaser	3124	Oak Ridge ES
Computer	Dell	80045655934848	Oak Ridge ES
Monitor		CNOUH8384822083805ZI	Oak Ridge ES

<u>DESCRIPTION</u>	<u>MAKE/MODEL</u>	<u>I.D./SERIAL</u>	<u>DEPT/SITE</u>
Phaser Printer	Xerox	YGG991322	Oak Ridge ES
Printer	Xerox	VNB3F60619	Oak Ridge ES
Laptop	Dell	D132321	Rhodes ES
Laptop	Dell	96HRYW1	Rhodes ES
Projector	Epson	KM3F010936L	Rhodes ES
Projector	Epson	JXJF789880L	Rhodes ES
Projector	Epson	JXJF789888L	Rhodes ES
Doc Camera	Epson	TKJF4900370	Rhodes ES
Printer	Xerox	36520	Rolling Ridge ES
Printer	Xerox		Rolling Ridge ES
Overhead Projector		C159044	Rolling Ridge ES
Overhead Projector		C173402	Rolling Ridge ES
TV	SHARP	A605827692	Rolling Ridge ES
TV	RCA	E505DA1Q2	Rolling Ridge ES
TV	SHARP	A607843778	Rolling Ridge ES
TV	SAMSUNG	3CAH200132	Rolling Ridge ES
TV	SAMSUNG	3CAH20D136	Rolling Ridge ES
TV	GE.	420521649	Rolling Ridge ES
TV	SHARP	A605827688	Rolling Ridge ES
TV	SHARP	A607843777	Rolling Ridge ES
TV	SHARP	751335	Rolling Ridge ES
Printer	Xerox	UAG536834	Rolling Ridge ES
Microwave	LG	LRM2060ST	Magnolia JHS
Refrigerator	Frigidaire		Magnolia JHS
TV	Sharp 27K-S180	660278	Magnolia JHS
TV	Sharp 27K-S180	11641	Magnolia JHS
TV	Philips	YA1A053739406	Magnolia JHS
Couch			Magnolia JHS
Overhead Projector	Epson	GM9G5Y40464	Woodcrest JHS
Overhead Projector	Epson	2246	Woodcrest JHS
Overhead Projector	Epson	22242	Woodcrest JHS
Overhead Projector	Epson	33869	Woodcrest JHS
Overhead Projector	Epson	33871	Woodcrest JHS
Overhead Projector	Epson	31618	Woodcrest JHS
Overhead Projector	Epson	222444	Woodcrest JHS
Overhead Projector	Epson	17086	Woodcrest JHS
Computer	Dell	44026	Woodcrest JHS
Speaker System	Creative-I-TRIGUE	CAMF0245401002310X	Woodcrest JHS
Keyboard	Dell		Woodcrest JHS
Printer	HP Laserjet	22227	Woodcrest JHS
DVD Player	GoVideo	551215010776	Woodcrest JHS

<u>DESCRIPTION</u>	<u>MAKE/MODEL</u>	<u>I.D./SERIAL</u>	<u>DEPT/SITE</u>
Document Camera	AverMedia	31625	Woodcrest JHS
Document Camera	AverMedia	30000	Woodcrest JHS

**CHINO VALLEY UNIFIED SCHOOL DISTRICT**

**Our Motto:**

Student Achievement • Safe Schools • Positive School Climate  
Humility • Civility • Service

**DATE:** June 28, 2018  
**TO:** Members, Board of Education  
**FROM:** Wayne M. Joseph, Superintendent  
**PREPARED BY:** Gregory J. Stachura, Asst. Supt., Facilities, Planning, and Operations  
Anna G. Hamilton, Director, Purchasing  
**SUBJECT: BID 17-18-30F, FORMER EL RANCHO ES SCHOOL NETWORK**

=====

**BACKGROUND**

Public Contract Code 20111 requires that contracts for public works exceeding \$15,000.00 be legally advertised and awarded to the lowest responsible bidder, who shall have such surety as the Board requires.

A Notice to Contractors Calling for Bids for Bid 17-18-30F, Former El Rancho ES School Network was published in the Inland Valley Daily Bulletin on June 1, 2018 and June 8, 2018. Bids were opened at 1:00 p.m. on June 20, 2018. The results are as follows:

<b>Contractor</b>	<b>Bid Amount</b>
Federal Technology Solutions, Inc.	\$768,552.90

The basic scope of work for this project includes Network infrastructure, installation, mapping and configuration of network drops, wireless access points, firewall and cabling across all campus locations. Relocation of current MDF to new location on campus. Providing a cloud-based solution to manage all of network services. Provide on-going managed services to support the school network.

Approval of this item supports the goals identified within the District’s Strategic Plan.

**RECOMMENDATION**

It is recommended the Board of Education award Bid 17-18-30F, Former El Rancho ES School Network, to Federal Technology Solutions, Inc.

**FISCAL IMPACT**

\$768,522.90 to Bond Measure G Fund 21.

WMJ:GJS:pw



**CHINO VALLEY UNIFIED SCHOOL DISTRICT**

**Our Motto:**

Student Achievement • Safe Schools • Positive School Climate  
Humility • Civility • Service

**DATE:** June 28, 2018  
**TO:** Members, Board of Education  
**FROM:** Wayne M. Joseph, Superintendent  
**PREPARED BY:** Gregory J. Stachura, Asst. Supt. Facilities, Planning, and Operations  
Anna G. Hamilton, Director, Purchasing  
**SUBJECT: RESOLUTION 2017/2018-87 FOR AUTHORIZATION TO UTILIZE A PIGGYBACK CONTRACT**

=====  
**BACKGROUND**

Public Contract Code (PCC) 20111 requires school district governing boards to competitively bid and award any contracts involving an expenditure of more than \$86,000.00 to the lowest responsible bidder.

Notwithstanding PCC 20111, PCC 20118 and Administrative Regulation 3311 state that without advertising for bids and upon a determination that it is in the best interest of the District, the Board may authorize District staff by contract, lease, requisition, or purchase order of another public corporation or agency, to lease data-processing equipment, or to purchase materials, supplies, equipment, automotive vehicles, tractors and other personal property for the District in the manner that the other public corporation or agency is authorized to make the leases or purchases from a vendor (piggyback).

Alternatively, if there is an existing contract between a public corporation or agency and a vendor for the lease or purchase of personal property, the District may authorize the lease or purchase of personal property directly to the vendor under the same terms that are available to the public corporation or agency under the contract.

Staff requests approval of the following resolution to provide authorization for the District to participate by piggyback in contract as itemized below:

<b>Resolution</b>	<b>Contract</b>	<b>Contractor</b>	<b>Description</b>	<b>Term</b>
2017/2018-87 Original Resolution 2017/2018-26	DGS Participating Addendum 7-16-70-37 Amendment 1	CW Government LLC	Software Value Added Reseller (VAR)	Extended from 10/12/2016-4/7/2018 to 4/7/2019

Approval of this item supports the goals identified within the District's Strategic Plan.

**RECOMMENDATION**

It is recommended the Board of Education adopt Resolution 2017/2018-87 for authorization to utilize a piggyback contract.

**FISCAL IMPACT**

Unknown.

WMJ:GJS:AGH:pw

**Chino Valley Unified School District  
Resolution 2017/2018-87  
Authorization to Utilize the DGS Participating Addendum 7-16-70-37  
Amendment 1, Original Resolution 2017/2018-26  
With CW Government LLC  
to Purchase Software Value Added Reseller (VAR)  
Through the Piggyback Contract**

**WHEREAS**, the Board of Education (Board) of the Chino Valley Unified School District (District) has determined that a true and very real need exists to procure Software VAR for the District;

**WHEREAS**, DGS Participating Addendum currently has a piggyback contract, 7-16-70-37 amendment 1, in accordance with Public Contract Code 20118 with CW Government LLC that contains the materials, supplies, equipment and/or other personal property the District currently requires;

**WHEREAS**, the board of education of a school district, without advertising for bids, if the board has determined it to be in the best interests of the district, may authorize by contract, lease, requisition, or purchase order of any public corporation or agency, including any county, city, town, or district, to lease data-processing equipment, purchase materials, supplies, equipment, automotive vehicles, tractors, and other personal property for the district in the manner in which the public corporation or agency is authorized by law to make the leases or purchases from a vendor;

**WHEREAS**, the board of education of a school district is required to make a determination that a purchase and/or lease through a public corporation or agency is in the best interests of the district to take advantage of this exception; and

**WHEREAS**, the Board has determined that it is in the best interest of the District to authorize the purchase of Software VAR through the piggyback contract procured by the DGS Participating Addendum 7-16-70-37 amendment1.

**NOW, THEREFORE, BE IT RESOLVED** the Board hereby finds, determines, and declares as follows:

Section 1. Determination re: Recitals. All of the recitals set forth above are true and correct.

Section 2. Determination re: Purchase through Other Public Agency. Pursuant to Public Contract Code 20118, that authorizing the purchase of Software VAR through the piggyback contract originally procured by the DGS Participating Addendum 7-16-70-37 amendment 1 is in the best interests of the District because there is volume pricing that can be used to reduce the District's overall price.

Section 3. Authorization. The Board hereby authorizes the acquisition of Software VAR in accordance with Public Contract Code 20118 through the piggyback contract originally procured by the DGS Participating Addendum 7-16-70-37 amendment 1.

Section 4. Other Actions. The Superintendent or his designee are each hereby authorized and directed, jointly and severally, to do any and all things and to execute and deliver any and all documents which they may deem necessary or advisable in order to consummate the purchase, sale, and lease, and otherwise to carry out, give effect to and comply with the terms and intent of this Resolution, and that any and all such prior actions by the District's Superintendent, or his designee, are hereby ratified by the Board.

Section 5. Effective Date. This resolution shall be effective as of October 12, 2016, for the term ending April 7, 2019.

**APPROVED, PASSED, AND ADOPTED** by the Board of Education of the Chino Valley Unified School District this 28th day of June 2018 by the following vote:

Blair	_____
Cruz	_____
Feix	_____
Na	_____
Orozco	_____

I, Wayne M. Joseph, Secretary of the Chino Valley Unified School District Board of Education, do hereby certify that the foregoing is a full, true, and correct copy of the Resolution passed and adopted by said Board at a regularly scheduled and conducted meeting held on said date, which Resolution is on file in the office of said Board.

---

Wayne M. Joseph, Superintendent  
Secretary, Board of Education

**CHINO VALLEY UNIFIED SCHOOL DISTRICT**

**Our Motto:**

Student Achievement • Safe Schools • Positive School Climate  
Humility • Civility • Service

**DATE:** June 28, 2018  
**TO:** Members, Board of Education  
**FROM:** Wayne M. Joseph, Superintendent  
**PREPARED BY:** Gregory J. Stachura, Asst. Supt., Facilities, Planning, and Operations  
Anna G. Hamilton, Director, Purchasing  
**SUBJECT: CHANGE ORDERS FOR PHASE 2 PROJECT DESIGN AND CONSTRUCTION OF ENERGY EFFICIENCY MEASURES 1 AND 2 AT VARIOUS SITES**

=====

**BACKGROUND**

On May 19, 2016, the Board of Education approved Phase 2 Project Design and Construction of Energy Efficiency Measures 1 and 2 at Various Sites to Trane U.S., Inc. During the course of construction, modifications to the original approved plans were made due to unforeseen conditions, revisions, or amended project scope. The following change orders have been reviewed and recommended for approval by District staff.

<b>Change Order</b>	<b>Description</b>	<b>Amount</b>
	Original contracted amount	\$3,516,824.50
	Guaranteed Rebates	(\$212,152.00)
	New Contracted amount- net of guaranteed rebate	\$3,304,672.50
1	Revision and approval of existing DSA Approved projects.	\$169,554.67
2	Construction cost addition after redesign and reduction of lighting scope.	\$279,724.44
3	Utility outlet code compliance.	\$23,200.00
Revised Total Project Amount:		\$3,777,151.61

The change orders result in a net increase of \$472,479.11 to the construction cost and no change in contract time. The revised total project cost, including all change orders, is \$3,777,151.61. Approval of the change orders allows for compensation to the contractor to perform the additional work as described.

The total change order amount exceeds the legal limit of 10% of the total bid amount. Change orders 1 and 3 as noted above represent work required specifically due to unforeseen field conditions and/or code requirements. County Counsel has reviewed and approved that this item does not count toward the 10% change order limit.

Approval of this item supports the goals identified within the District's Strategic Plan.

**RECOMMENDATION**

It is recommended the Board of Education approve the change orders for Phase 2 Project Design and Construction of Energy Efficiency Measures 1 and 2 at Various Sites.

**FISCAL IMPACT**

\$185,690.00 to Prop 39 Fund 01.

\$286,789.11 to RDA Fund 25.

WMJ:GJS:AGH:pw



# Proposal

Southern California Trane  
Tyler Clemmer  
District Manager  
CA State Contractors License # 561796  
Commercial Sales  
Expiration Date: 3/31/18

3253 E. Imperial Hwy.  
Brea, CA 92821  
TEL 626 913-7123  
FAX 626 913-8419

To: Chino Valley USD  
5130 Riverside Dr.  
Chino, CA 91710

Date: 9/15/17

Proposal Number: 2

Attn: Martin Silveira

Payment Terms: Net 30 Days

Re: Don Lugo Prop 39 Implementation, Phase II  
Trane job no. PID46985

Subject: Change Order Proposal #2

District requested change order to reengineer the replacement of HVAC units at Don Lugo HS with new Carrier manufactured units instead of Trane manufactured units per the original design.

Under this change-order Trane will complete the following:

- A. Obtain approvals for funding from California Energy Commission (CEC):
  - a. Submit amendment to Energy Expenditure Plan to CEC
  - b. Guide Energy Expenditure Plan to approval from CEC
- B. Review final equipment selection and construction documents with District personnel
  - a. Review and get approval on proposed equipment prior to DSA submission
- C. Provide an updated proposal for construction of the scope based on final construction documents.

Trane will provide 100% construction documents for complete mechanical, electrical, and plumbing services for the replacement of 136 rooftop packaged units at Don Lugo High School. The project will be designed to comply with DSA standards as well as Proposition 39 SIR requirements. The scope of work will entail revising the existing DSA approved Phase I (A#04-115618) and Phase II (A#04-115619) projects per the initial proposed scope listed below.

Price: \$169,554.67

Respectfully,

*Ron Miller*

Ron Miller  
Project Manager  
Page 1 of 3

**ACCEPTANCE: Please sign and return one copy.**

THIS PROPOSAL IS ACCEPTED THIS 18th DAY OF June, 18/ 2018

PURCHASE ORDER 172687/180083 FIRM \_\_\_\_\_

BY [Signature] TITLE Assistant Superintendent



### Standard Contract Terms and Conditions

**Acceptance.** A proposal made upon these terms is subject to acceptance within thirty days from date and the prices are subject to change without notice prior to acceptance by Customer. If your order is an acceptance of a written proposal, on a form provided by Trane, without the addition of any other terms and conditions of sale or any other modification, this document shall be treated solely as an acknowledgment of such order, subject to credit approval. If your order is not such an acceptance, then this document is Trane's offer, subject to credit approval, to provide the goods and/or Work solely in accordance with the following terms and conditions of sale. If we do not hear from you within two weeks from the date hereof, Trane shall rely upon your silence as an acceptance of these terms and conditions and performance will be made in accordance herewith. Customer's acceptance of goods and/or Work by Trane on this order will in any event constitute an acceptance by Customer of these terms and conditions.

**Contract Price.** The Contract Price includes standard ground transportation and all sales, consumer, use and similar taxes legally enacted as of the date hereof only for equipment and material installed by Trane and labor as required by law. Equipment sold on an uninstalled basis does not include sales tax and applicable taxes will be added.

**Exclusions From Work.** Trane's obligation is limited to the Work as defined and does not include any modifications to the Premises under the Americans With Disabilities Act or any other law or building code(s).

**Construction Procedures.** Trane shall supervise and direct the Work using its best skill and attention and have exclusive control over construction means, methods, techniques, sequences and procedures.

**Payment Terms.** Customer shall pay Trane's invoices within net thirty (30) days of invoice date. Trane may invoice Customer for all equipment or material furnished, whether delivered to the installation site or to an off-site storage facility and for all work performed on-site or off-site. No retention shall be withheld from any payments except as expressly agreed in writing by Trane, in which case retention shall be reduced per the contract documents and released no later than the date of substantial completion. Under no circumstances shall any retention be withheld for the equipment portion of the order. If payment is not received as required hereby, Trane may suspend performance and the time for completion shall be extended for a reasonable period of time not less than the period of suspension. Customer shall be liable to Trane for all reasonable shutdown, standby and start-up costs as a result of the suspension. All amounts outstanding 10 days beyond the due date are subject to a service charge not to exceed 1.5% of the principal amount due or the maximum allowable legal interest rate, retroactive to the due date. Customer shall pay all costs (including attorneys' fees) incurred by Trane in attempting to collect amounts due and otherwise enforcing these terms and conditions.

**Time For Completion.** Except to the extent otherwise expressly agreed in writing signed by an authorized representative of Trane, all dates provided by Trane or its representatives for commencement, progress or completion are estimates only. While Trane shall use commercially reasonable efforts to meet such estimated dates, Trane shall not be responsible for any damages for its failure to do so.

**Access.** Trane and its contractors or subcontractors shall be provided access to the Premises during regular business hours, or such other hours as may be requested by Trane and acceptable to the Premises' owner or tenant for the performance of the Work, including sufficient areas for staging, mobilization, and storage. Trane's access to correct any emergency condition shall not be restricted.

**Permits And Governmental Fees.** Trane shall secure (with Customer's assistance) and pay for building and other permits and governmental fees, licenses, and inspections necessary for proper performance and completion of the Work, which are legally required when bids from Trane's subcontractors are received, negotiations thereon concluded, or the effective date of a relevant Change Order, whichever is later. Customer is responsible for necessary approvals, easements, assessments and charges for construction, use or occupancy of permanent structures or for permanent changes to existing facilities.

**Utilities During Construction.** Trane shall be provided without charge all water, heat, and utilities during performance of the Work.

**Concealed Or Unknown Conditions.** In the performance of the Work, if Trane encounters conditions at the Premises that are (i) subsurface or otherwise concealed physical conditions that differ materially from those indicated on drawings expressly incorporated herein or (ii) unknown physical conditions of an unusual nature that differ materially from those conditions ordinarily found to exist and generally recognized as inherent in construction activities of the type and character as the Work, Trane shall notify Customer of such conditions promptly, prior to significantly disturbing the same. If such conditions differ materially and cause an increase in Trane's cost of, or time required for, performance of any part of the Work, Trane shall be entitled to, and Customer shall consent by Change Order to, an equitable adjustment in the Contract Price, contract time, or both.

**Asbestos And Hazardous Materials.** Trane's Work and other services in connection with this Agreement expressly excludes any identification, abatement, cleanup, control, disposal, removal or other work connected with asbestos, polychlorinated biphenyl ("PCB"), or other hazardous materials (hereinafter, collectively, "Hazardous Materials"). Customer warrants and represents that, except as set forth in a writing signed by Trane, there are no Hazardous Materials on the Premises that will in any way affect Trane's Work and Customer has disclosed to Trane the existence and location of any Hazardous Materials in all areas within which Trane will be performing the Work. Should Trane become aware of or suspect the presence of Hazardous Materials, Trane may immediately stop work in the affected area and shall notify Customer. Customer will be responsible for taking any and all action necessary to correct the condition in accordance with all applicable laws and regulations. Customer shall be exclusively responsible for any claims, including the payment thereof, arising out of or relating to any Hazardous Materials on or about the Premises, not brought onto the Premises by Trane. Trane shall be required to resume performance of the Work in the affected area only in the absence of Hazardous Materials or when the affected area has been rendered harmless. In no event shall Trane be obligated to transport or handle Hazardous Material, to provide any notices to any governmental agency, or to examine the Premises for the presence of Hazardous Materials.

**Conditions Beyond Control Of Parties.** If Trane shall be unable to carry out any material obligation under this Agreement due to events beyond its control, such as acts of God, governmental or judicial authority, insurrections, riots, labor disputes, labor or material shortages, fires, or explosions, this Agreement shall at Trane's election (i) remain in effect but Trane's obligations shall be suspended until the uncontrollable event terminates; or (ii) be terminated upon ten (10) days notice to Customer, in which event Customer shall pay Trane for all parts of the Work furnished to the date of termination.

**Customer's Breach.** Each of the following events or conditions shall constitute a breach by Customer and shall give Trane the right, without an election of remedies, to terminate this Agreement by delivery of written notice declaring termination, upon which event Customer shall be liable to Trane for all Work furnished to date and all damages sustained by Trane (including lost profit and overhead): (1) Any failure by Customer to pay amounts due more than thirty (30) days after the date of the invoice therefor; or (2) Any failure by Customer to perform or comply with any material provision of this Agreement.

**Indemnification.** Trane and Customer shall indemnify, defend and hold each other harmless from any and all claims, actions, costs, expenses, damages and liabilities, including reasonable attorneys' fees, resulting from death or bodily injury or damage to real or personal property, to the extent caused by the negligence or misconduct of their respective employees or other authorized agents in connection with their activities within the scope of this Agreement. However, neither party shall indemnify the other against claims, damages, expenses or liabilities to the extent attributable to the negligence or misconduct of the other party. If the parties are both at fault, the obligation to indemnify shall be proportional to their relative fault. The duty to indemnify will continue in full force and effect, notwithstanding the expiration or early termination hereof, with respect to any claims based on facts or conditions that occurred prior to expiration or termination. Notwithstanding any contrary provision, neither party shall be liable to the other for any special, incidental, consequential or punitive damages.





# Proposal

Southern California Trane  
Tyler Clemmer  
District Manager  
CA State Contractors License # 561796  
Commercial Sales  
Expiration Date: 3/31/18

3253 E. Imperial Hwy.  
Brea, CA 92821  
TEL 626 913-7123  
FAX 626 913-8419

To: Chino Valley USD  
5130 Riverside Dr.  
Chino, CA 91710

Date: 3/20/18

Proposal Number: 3

Attn: Martin Silveira

Payment Terms: Net 30 Days

Re: **Don Lugo Prop 39 Implementation, Phase II**  
**Trane job no. PID46985**

Subject: Change Order Proposal #3

District requested change order to install Day and Night HVAC units (Carrier equivalent unit) instead of Trane HVAC units at Don Lugo HS to eliminate the need for adaptive curbs.

Under this change-order the following are additions and deductions to the contract:

1. Construction Cost Addition after Redesign w/ Day and Night units: \$407,028.13
2. Deduction for Reduced Lighting Scope:
  - Howard Cattle ES: \$93,432.92
  - Poll Lights: \$33,870.77

The scope of work is to re-use the existing curbs when replacing the existing Carrier units with Day/Night units and to demo all non-Carrier units and curbs down to the roofline. Non-Carrier units and curbs will be replaced with a new curb and a Trane HVAC unit.

**Net Change Order Price: \$279,724.44**

Respectfully,

*Ron Miller*

Ron Miller  
Project Manager

**ACCEPTANCE: Please sign and return one copy.**

THIS PROPOSAL IS ACCEPTED THIS 18th DAY OF June, 19 2018

PURCHASE ORDER 172687/180083 FIRM \_\_\_\_\_

BY [Signature] TITLE Assistant Superintendent

# Proposal



Southern California Trane  
Tyler Clemmer  
District Manager  
CA State Contractors License # 561796  
Commercial Sales  
Expiration Date: 3/31/18

3253 E. Imperial Hwy.  
Brea, CA 92821  
TEL 626 913-7123  
FAX 626 913-8419

To: Chino Valley USD  
5130 Riverside Dr.  
Chino, CA 91710

Date: 5/24/18

Proposal Number: 4

Attn: Martin Silveira

Payment Terms: Net 30 Days

Re: Don Lugo Prop 39 Implementation, Phase II  
Trane job no. PID46985

Subject: Change Order Proposal #4

Utility outlets on many of the buildings do not comply with the current code requirements. Utility outlets are to be GFI outlets and located within 25 feet of all equipment. Trane's scope of work is not intended to include remediation of any existing code deficiencies

Under this change-order Trane will complete the following:

- Replace existing outlets with GFI outlets on buildings A (4 outlets), B (5 outlets), C (7 outlets), D1/D2/D3 (2 outlets), G (1 outlet), K (1 outlet) and T (1 outlet) for a total of 21 GFI outlets.
- Provide a factory mounted GFI outlet on RTU's on buildings A (8 units), C (8 units), D1/D2/D3 (5 units), F (1 units), U (4 units) and V (4 units) for a total of 30 units with factory mounted GFI outlets.

Price: \$23,200.00

Respectfully,

*Ron Miller*

Ron Miller  
Project Manager

<b>ACCEPTANCE: Please sign and return one copy.</b>	
THIS PROPOSAL IS ACCEPTED THIS	18th DAY OF June, 18/ 2018
PURCHASE ORDER	172687/180083 FIRM
BY	TITLE Assistant Superintendent

**CHINO VALLEY UNIFIED SCHOOL DISTRICT**

**Our Motto:**

Student Achievement • Safe Schools • Positive School Climate  
Humility • Civility • Service

**DATE:** June 28, 2018  
**TO:** Members, Board of Education  
**FROM:** Wayne M. Joseph, Superintendent  
**PREPARED BY:** Gregory J. Stachura, Asst. Supt., Facilities, Planning, and Operations  
**SUBJECT: REIMBURSEMENT AGREEMENT FOR DSA INSPECTION SERVICES THROUGH T-MOBILE**

=====  
**BACKGROUND**

On July 11, 2003, the Board of Education approved a land lease agreement with Pac Bell Wireless, LLC, dba Cingular Wireless (now dba T-Mobile) to construct and install a faux pine tree cellular tower/antenna array at Don Lugo High School. Per this agreement, all changes, modifications and improvements to the cellular tower/antenna array must be approved by the California Department of State Architect (DSA).

T-Mobile is proposing changes to the cellular tower/antenna array which require DSA approval. As part of the approval process, a DSA inspector is required to inspect and certify that the changes are per the DSA approved plans and specifications. The District will be providing the DSA inspector through its Board approved inspection service provider, TYR Inspections. T-Mobile will reimburse the District for these costs through the reimbursement agreement.

Approval of this item supports the goals identified within the District's Strategic Plan.

**RECOMMENDATION**

It is recommended the Board of Education approve the Reimbursement Agreement for DSA Inspection Services through T-Mobile.

**FISCAL IMPACT**

None.

WMJ:GJS:pw

## AGREEMENT FOR ADVANCE OF FUNDS

(Reimbursement Agreement for Inspector Services)

This Agreement for Advance of Funds (the "Agreement") is entered into as of the latest date entered on page 2 of this Agreement (the "Effective Date") by and between the Chino Valley Unified School District (the "District") and T-Mobile ("T-Mobile"). District and T-Mobile may be referred to in this Agreement collectively as the "Parties."

### WITNESSETH

**WHEREAS**, the District awarded a Communications Site License Agreement to T-Mobile on July 11, 2003 to construct, maintain and operate on the licensed premises at Don Lugo High School, located at 13400 Pipeline Ave., Chino, CA 91710 (the "Premises") certain communications facilities to be used for mobile wireless communications services (the "Project"); and

**WHEREAS**, the Department of General Services, Division of the State Architect ("DSA") is requiring that certain Project upgrades be performed by T-Mobile to achieve Project Close-Out, consistent with the plans and specifications approved by DSA and as more particularly described in Exhibit "A" attached hereto and incorporated herein by this reference (the "Work");

**WHEREAS**, consistent with Education Code section 17311, District has entered into a contract for competent, adequate, and continuous inspection during the construction of the Work ("Inspection Services") with TYR Inspection Services, a firm satisfactory to the District and to DSA (the "IOR"); and

**WHEREAS**, the District has agreed to advance the cost for the Inspection Services and T-Mobile has agreed to reimburse District for such costs per Exhibit "B" attached hereto and incorporated herein;

**NOW, THEREFORE**, in consideration of the above recitals and the terms and conditions set forth hereinafter, the Parties agree as follows:

1. The District agrees to advance the costs incurred by the IOR for the Inspection Services related to the Work.

2. T-Mobile agrees to reimburse the District for the costs advanced by the District to compensate the IOR for the Inspection Services upon receipt of District's monthly invoice, supported by the IOR's detailed invoice of work performed. T-Mobile shall pay all such invoices within 14 business days from the date of each such invoice payable to the District at the following address:

Chino Valley Unified School District  
5130 Riverside Drive  
Chino, California 91710-4130  
Attn: Gregory Stachura

3. The Parties agree that the IOR's compensation for the Inspection Services shall not exceed **Six Thousand Nine Hundred Seventy-Two Dollars (\$6,972.00)**, unless such amount is increased with the mutual written consent of the Parties.

4. The term of this Agreement shall commence as of the Effective Date and shall continue until the Work has been completed and the IOR has complied with all applicable requirements of DSA Procedure: Project Certification Process (PR 13-02), revised July 25, 2014, or successor DSA Procedure.

5. Neither party may assign its rights or obligations under this Agreement to another party.

6. This Agreement may only be amended in writing by mutual consent of the Parties.

IN WITNESS WHEREOF, the Parties hereto have caused this Agreement to be executed.

**CHINO VALLEY UNIFIED SCHOOL DISTRICT**

**T-MOBILE WEST LLC**

By: \_\_\_\_\_

By: 

Name: Gregory J. Stachura

Name: **Kamal Sadarangani**  
**Director**

Title: Assistant Superintendent

Title: **Southern California Market  
Network Engineering & Ops  
T-Mobile, USA Inc.**

Date: \_\_\_\_\_

Date: 6/12/18

**EXHIBIT "A"**  
**DESCRIPTION OF WORK**







NO.	DATE	DESCRIPTION	BY
1	04/10/17	ISSUE CD	LR
2	04/17/17	ISSUE CD	LR
3	04/27/17	ISSUE CD	LR

**SB228 DON LUGO HIGH SCHOOL**  
 CHINA PUEBLO JUNIOR HIGH SCHOOL DISTRICT  
 CHINA, CALIFORNIA  
 SAN BERNARDINO COUNTY



**GENERAL NOTES, ANTENNA & CABLE SCHEDULE, LEGEND & ABBREVIATIONS**

**T-2**

**GENERAL CONSTRUCTION NOTES:**

- THE FACILITY IS AN UNLICENSED TELECOMMUNICATION FACILITY.
- PLANS ARE NOT TO BE SCALED AND ARE INTENDED TO BE A DIAGNOSTIC DRAWING ONLY. UNLESS NOTED OTHERWISE, THE WORK SHALL INCLUDE EXISTING UTILITIES, FOUNDATIONS, AND UTILITIES AND LABOR NECESSARY TO COMPLETE ALL INSTALLATIONS AS INDICATED ON THE DRAWINGS.
- FOR THE PROTECTION OF THE CONTRACTOR, THE CONTRACTOR SHALL VERIFY THE JOB SITE AND BE RESPONSIBLE FOR OBTAINING ALL NECESSARY PERMITS AND APPROVALS PRIOR TO PROCEEDING WITH THE WORK. THE CONTRACTOR SHALL BE RESPONSIBLE FOR OBTAINING ALL NECESSARY PERMITS AND APPROVALS PRIOR TO PROCEEDING WITH THE WORK.
- THE CONTRACTOR SHALL VERIFY A WORKING ALLOCATION IS PROVIDED BEFORE COMMENCING WORK ON ANY JOB FOR THE CLIENT'S REVIEW OF THE CONTRACT DOCUMENTS.
- CONTRACTOR SHALL CONTACT THE CLIENT IMMEDIATELY UPON IDENTIFICATION OF ANY DISCREPANCY OR CONFLICT WITH THE CONTRACT DOCUMENTS.
- THE CONTRACTOR SHALL VERIFY ALL MATERIALS AND METHODS IN ACCORDANCE WITH ALL APPLICABLE CODES, REGULATIONS AND ORDINANCES. THE CONTRACTOR SHALL VERIFY THAT ALL APPLICABLE CODES, REGULATIONS AND ORDINANCES ARE IN EFFECT AT THE TIME OF CONSTRUCTION AND COMPLY WITH ALL LAWS, ORDINANCES, RULES, REGULATIONS AND LAWFUL REQUIREMENTS OF THE CONTRACTING JURISDICTION. THE CONTRACTOR SHALL VERIFY THAT ALL APPLICABLE MATERIALS AND METHODS ARE IN ACCORDANCE WITH ALL APPLICABLE CODES, REGULATIONS AND ORDINANCES AND WITH THE LANDLORD'S ASSOCIATIONAL CODES, ORDINANCES AND APPLICABLE REGULATIONS.
- THE GENERAL CONTRACTOR SHALL SUPERVISE AND DIRECT THE WORK, ENSURING THE BEST SKILLS AND ATTENTION. THE CONTRACTOR SHALL BE SOLELY RESPONSIBLE FOR ALL WORK AND SHALL BE RESPONSIBLE FOR OBTAINING ALL NECESSARY PERMITS AND APPROVALS PRIOR TO COMMENCING ALL PORTIONS OF THE WORK UNDER THE CONTRACT INCLUDING CONTACT AND COORDINATION WITH THE INFORMATION ENGINEER AND WITH THE LANDLORD'S ASSOCIATED REPRESENTATIVE.
- SOIL PENETRATION THROUGH FIRE RATED WALLS WITH ALL LISTED AND FIRE CODE APPROVED MATERIALS PER SECTION 7054.
- PROVIDE A PORTABLE FIRE EXTINGUISHER WITH A RATING OF NOT LESS THAN 2-A OR 2-ABC WITHIN 75 FEET RANGE, DISTANCE TO ALL PORTIONS OF THE PROJECT AREA DURING CONSTRUCTION.
- ALL CONSTRUCTION SHALL BE IN ACCORDANCE WITH CHAPTER 16 OF THE CBC REGARDING ELECTRICAL, MECHANICAL, PLUMBING, CEILING, AND INTERIOR FINISHES AND MECHANICAL REGULATIONS. ALL WORK MUST BE IN ACCORDANCE WITH LOCAL, STATE, AND FEDERAL REGULATIONS.
- REVISIONS ARE INTENDED TO CORRECT THE RESULT OF REVISIONS. REVISIONS MUST BE REQUIRED TO LIST JOB DIMENSIONS OR CONDITIONS, AND SUCH REVISIONS SHALL BE INCLUDED AS PART OF THE WORK.
- THE CONTRACTOR SHALL TAKE NECESSARY PRECAUTIONS TO PREVENT (B) IMPROPERLY PLACED, CORRECTION, DAMAGED SURFACES, ETC., AND (C) COMPLETION OF THE WORK AFTER ANY CHANGE HAS OCCURRED DURING CONSTRUCTION TO THE STRUCTURE OF THE WORK.
- KEEP GENERAL AREA CLEAR, MAINTAIN FIRE, AND REMOVE ALL OIL, GREASE, RUBBER, AND OTHER DEBRIS NOT SPECIFIED AS REMAINING ON THE PROPERTY. LINE AND EQUIPMENT SHALL BE PROTECTED FROM DAMAGE BY TRUCKS, CARS, OR OTHER MOTOR VEHICLES.
- REPRESENTATIONS OF THIS WORK, WHICH HAVE BEEN MADE ON THE BASIS OF EXISTING DRAWINGS, SHALL NOT BE USED TO IDENTIFY OR ESTABLISH THE BOUNDARY OF THE WORK. AT THE SITE, THE CONTRACTOR SHALL BE RESPONSIBLE FOR THE IDENTIFICATION OF ALL EXISTING UTILITIES, FOUNDATIONS, AND OTHER STRUCTURES. THE CONTRACTOR SHALL BE RESPONSIBLE FOR THE IDENTIFICATION OF ALL EXISTING UTILITIES, FOUNDATIONS, AND OTHER STRUCTURES. THE CONTRACTOR SHALL BE RESPONSIBLE FOR THE IDENTIFICATION OF ALL EXISTING UTILITIES, FOUNDATIONS, AND OTHER STRUCTURES.
- FOR THE PROTECTION OF THE CONTRACTOR, THE CONTRACTOR SHALL VERIFY THE JOB SITE AND BE RESPONSIBLE FOR OBTAINING ALL NECESSARY PERMITS AND APPROVALS PRIOR TO PROCEEDING WITH THE WORK.
- FOR THE PROTECTION OF THE CONTRACTOR, THE CONTRACTOR SHALL VERIFY THE JOB SITE AND BE RESPONSIBLE FOR OBTAINING ALL NECESSARY PERMITS AND APPROVALS PRIOR TO PROCEEDING WITH THE WORK.

**GENERAL CONSTRUCTION NOTES (continued):**

- FOR THE PROTECTION OF THE CONTRACTOR, THE CONTRACTOR SHALL VERIFY THE JOB SITE AND BE RESPONSIBLE FOR OBTAINING ALL NECESSARY PERMITS AND APPROVALS PRIOR TO PROCEEDING WITH THE WORK.
- FOR THE PROTECTION OF THE CONTRACTOR, THE CONTRACTOR SHALL VERIFY THE JOB SITE AND BE RESPONSIBLE FOR OBTAINING ALL NECESSARY PERMITS AND APPROVALS PRIOR TO PROCEEDING WITH THE WORK.

**ABBREVIATIONS**

ANTENNA	ANTENNA	ANTENNA	ANTENNA
...	...	...	...

**LEGEND**

PROPERTY/LOOSE LINE	PROPERTY/LOOSE LINE
...	...

**EXISTING ANTENNA / CABLE SCHEDULE**

SECTION	ANTENNA	TYPE	SIZE	LENGTH	DATE	STATUS
A	...	...	...	...	...	...
B	...	...	...	...	...	...
C	...	...	...	...	...	...

**PROPOSED ANTENNA / CABLE SCHEDULE - RFDS VERSION 2.1**

SECTION	ANTENNA	TYPE	SIZE	LENGTH	DATE	STATUS
A	...	...	...	...	...	...
B	...	...	...	...	...	...
C	...	...	...	...	...	...

**GENERAL CONSTRUCTION NOTES**

1



**T-Mobile**  
Get more from life!  
2008 NEW AWARD  
WINNER OF BEST

**RLS**  
REGENT LAND SERVICES  
CONSULTING GROUP

NO.	DATE	DESCRIPTION	BY
1	04/10/17	ISSUE CD	LR
2	04/10/17	ISSUE CD	LR
3	04/10/17	ISSUE CD	LR
4	04/10/17	ISSUE CD	LR
5	04/10/17	ISSUE CD	LR
6	04/10/17	ISSUE CD	LR
7	04/10/17	ISSUE CD	LR
8	04/10/17	ISSUE CD	LR
9	04/10/17	ISSUE CD	LR
10	04/10/17	ISSUE CD	LR
11	04/10/17	ISSUE CD	LR
12	04/10/17	ISSUE CD	LR
13	04/10/17	ISSUE CD	LR
14	04/10/17	ISSUE CD	LR
15	04/10/17	ISSUE CD	LR
16	04/10/17	ISSUE CD	LR
17	04/10/17	ISSUE CD	LR
18	04/10/17	ISSUE CD	LR
19	04/10/17	ISSUE CD	LR
20	04/10/17	ISSUE CD	LR

**USE INFORMATION**  
IED4228A  
SB228 DON LUGO  
HIGH SCHOOL  
1000 PIPELINE AVENUE  
CERVO, CALIFORNIA  
92319-0000



**SHEET TITLE**  
SITE PLAN

**SHEET NUMBER**  
A-1

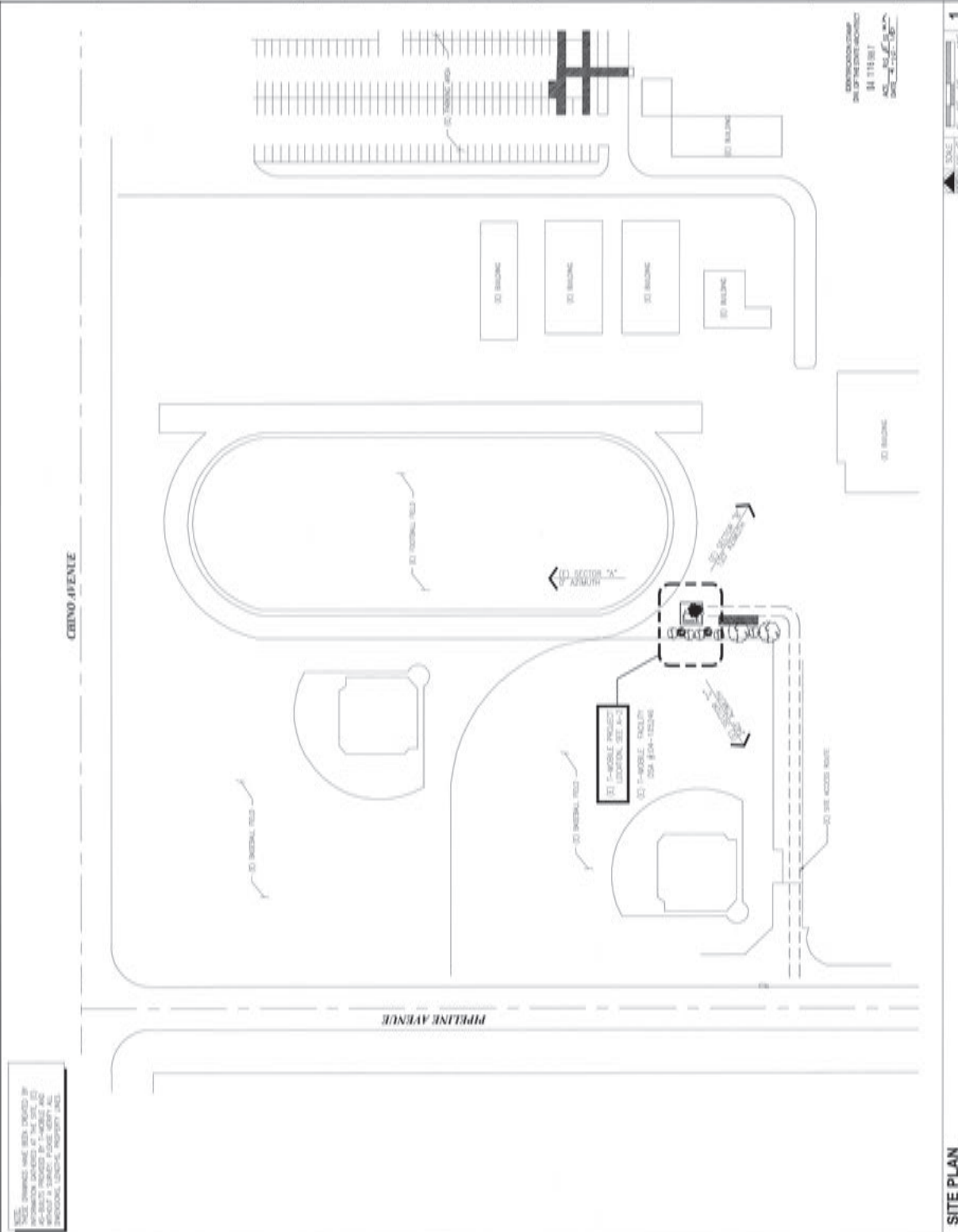

ALL DIMENSIONS ARE SHOWN UNLESS OTHERWISE NOTED. ALL DIMENSIONS ARE TO FACE UNLESS OTHERWISE NOTED. ALL DIMENSIONS ARE TO FACE UNLESS OTHERWISE NOTED.

**SITE PLAN**

NO.	DATE	DESCRIPTION	BY
4	04/10/17	ISSUE CD	LF
3	04/10/17	ISSUE CD	LF
1	01/20/16	ISSUE COMMENTS	BR

USE INFORMATION:  
**IED4228A**  
**SB228 DON LUGO**  
**HIGH SCHOOL**  
1000 W. WASH. AVENUE  
DENVER, COLORADO  
80202



SHEET TITLE:  
**EQUIPMENT LAYOUT  
PLAN & ANTENNA  
CONFIGURATION**

SHEET NUMBER:  
**A-2**

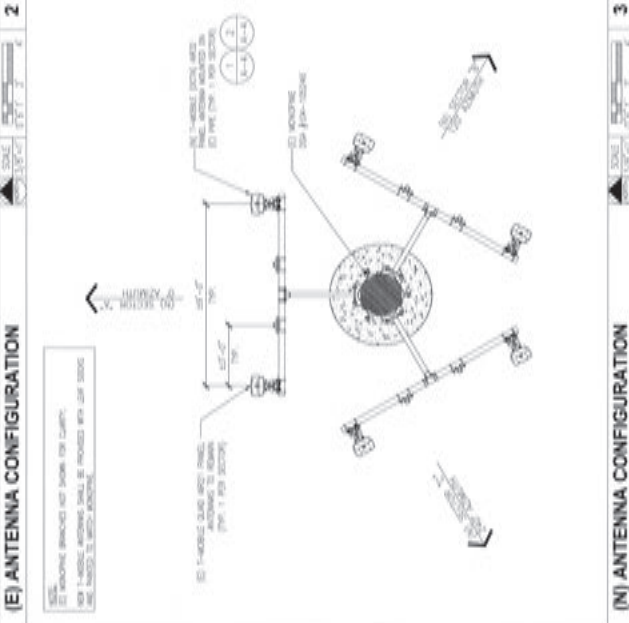
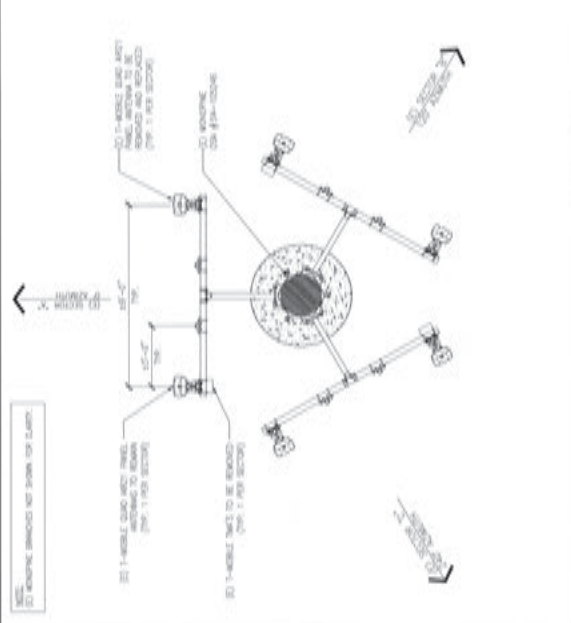
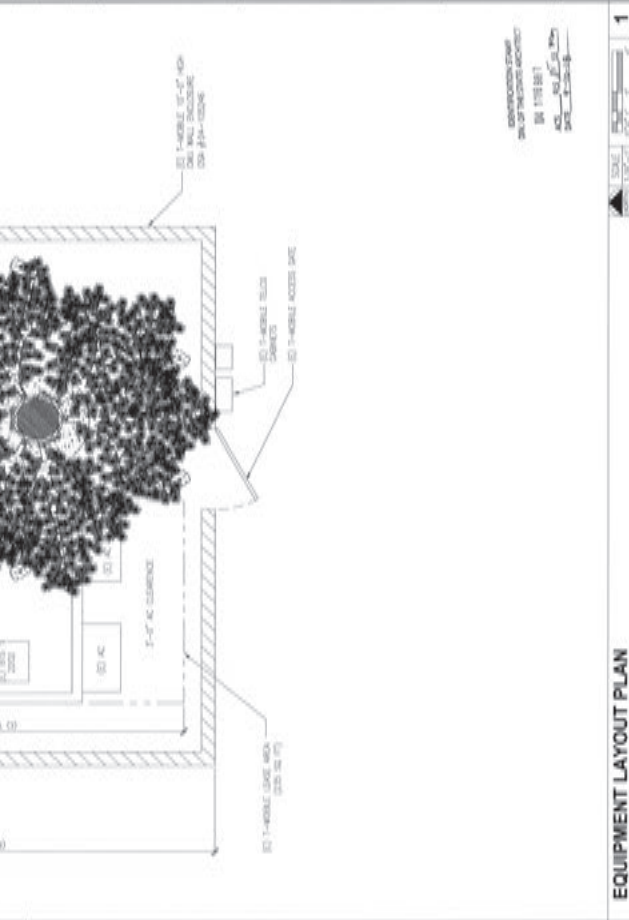

**T-Mobile**  
Get more from life  
SOLUTION ABOVE  
SMC, C. 2014

PLANS PREPARED BY  
**RLS**  
RELAY LAND SERVICES  
ARCHITECTURE & LANDSCAPE ARCHITECTURE  
CONSULTING GROUP

NO.	DATE	DESCRIPTION	BY
A	04/10/17	ISSUE CD	LR
B	04/17/17	ISSUE CD	LR
1	03/01/18	CSA COMMENTS	BR

SEE INFORMATION  
**IE04228A**  
**S8228 DON LUGO**  
**HIGH SCHOOL**  
THIRD PIPELINE ADDRESS  
ORANGE COUNTY  
SAN JUAN BAPTIST COUNTY



SHEET TITLE  
**ELEVATIONS**

SHEET NUMBER  
**A-3**

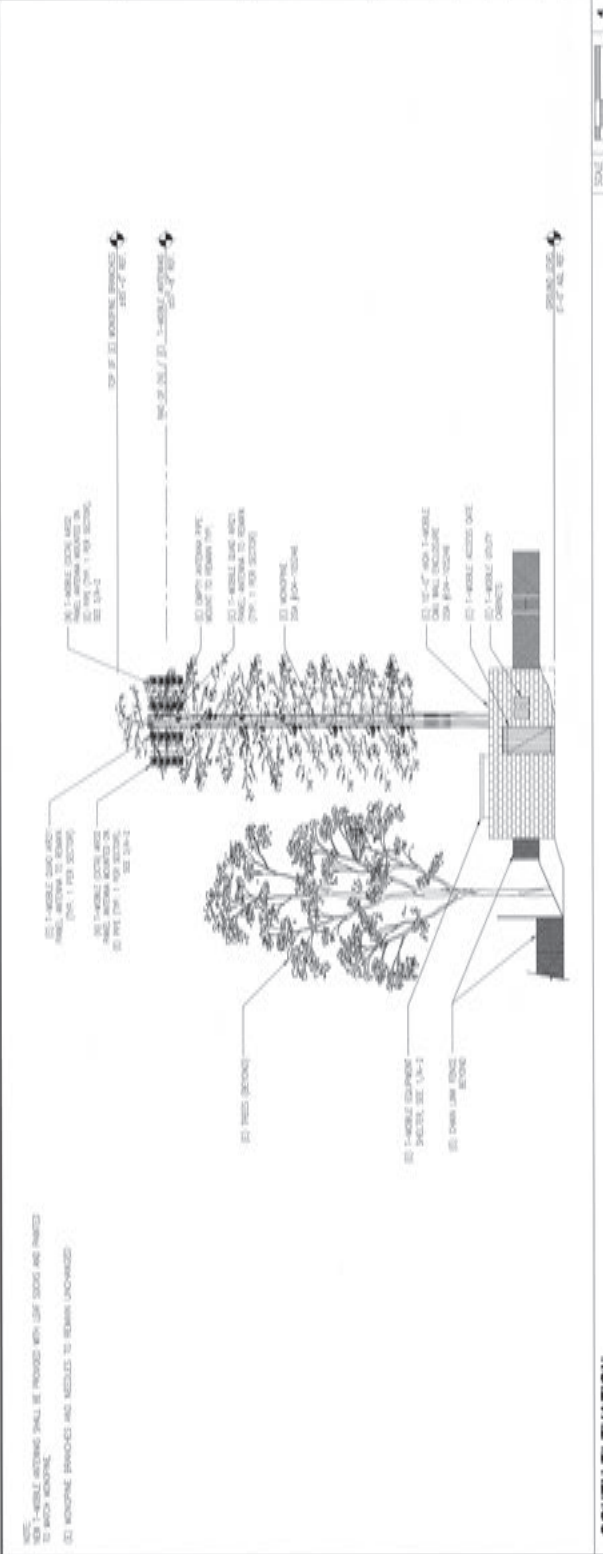

**SOUTH ELEVATION**

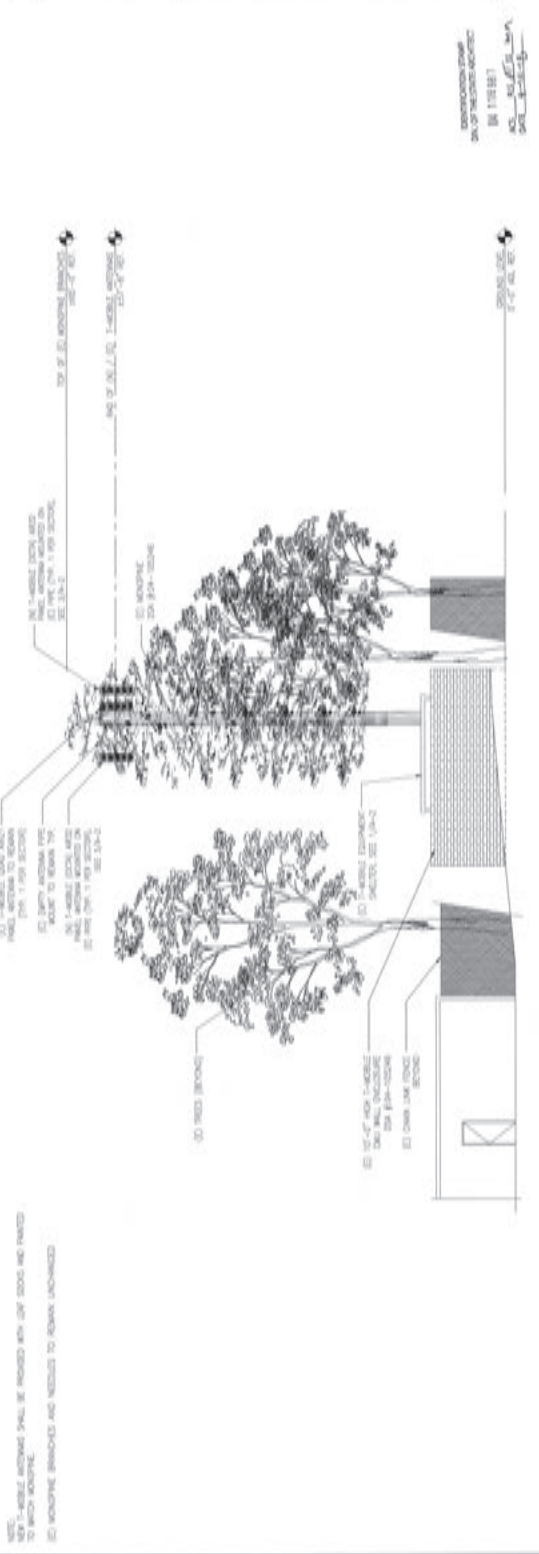

**EAST ELEVATION**

**T-Mobile**  
Get more from life!  
2008 AVENUE AVENUE  
AVENUE, CA 95041



PLANS PREPARED BY:  
DATE: 05/12/11  
BY: [Signature]  
CHECKED BY: [Signature]  
DATE: 05/12/11  
BY: [Signature]  
DATE: 05/12/11  
BY: [Signature]

NO.	DATE	DESCRIPTION	BY
1	05/12/11	ISSUE CD	LR
2	05/12/11	ISSUE CD	LR
3	05/12/11	ISSUE CD	LR
4	05/12/11	ISSUE CD	LR
5	05/12/11	ISSUE CD	LR
6	05/12/11	ISSUE CD	LR
7	05/12/11	ISSUE CD	LR
8	05/12/11	ISSUE CD	LR
9	05/12/11	ISSUE CD	LR
10	05/12/11	ISSUE CD	LR
11	05/12/11	ISSUE CD	LR
12	05/12/11	ISSUE CD	LR
13	05/12/11	ISSUE CD	LR
14	05/12/11	ISSUE CD	LR
15	05/12/11	ISSUE CD	LR
16	05/12/11	ISSUE CD	LR
17	05/12/11	ISSUE CD	LR
18	05/12/11	ISSUE CD	LR
19	05/12/11	ISSUE CD	LR
20	05/12/11	ISSUE CD	LR

PROJECT INFORMATION:  
PROJECT NO: IED4228A  
PROJECT NAME: SB228 DON LUGO HIGH SCHOOL  
PROJECT ADDRESS: 1000 PIPELINE AVENUE  
PROJECT CITY: CHICO, CALIFORNIA  
PROJECT COUNTY: BUTTE COUNTY



SHEET TITLE:  
**ANTENNA SPECS, SITE CONFIGURATION AND DETAILS**

SHEET NUMBER:  
**A-4**

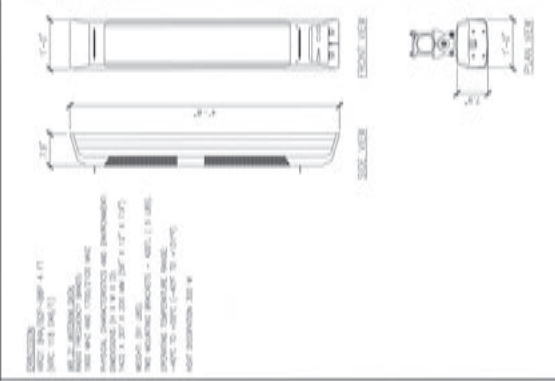
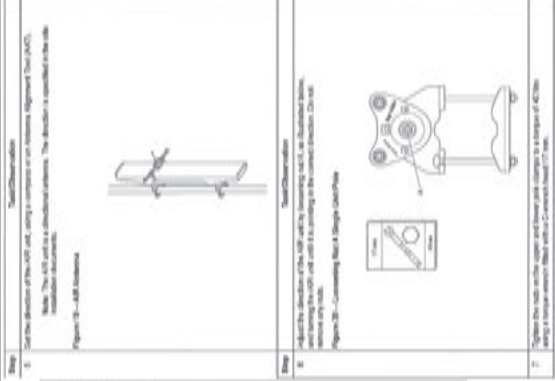
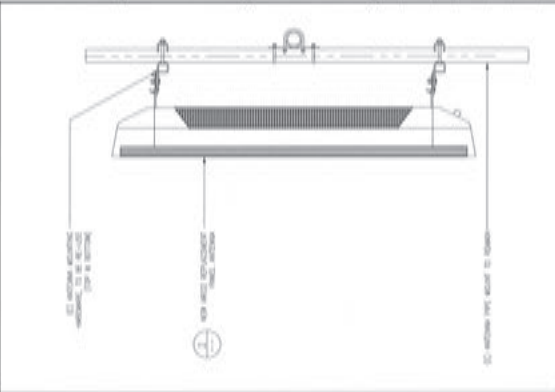

1 ANTENNA MOUNTING DETAIL  
SCALE: N.T.S.

3 AIR32 ANTENNA SPECIFICATIONS  
SCALE: N.T.S.

5 ANTENNA MOUNT SPECS  
SCALE: N.T.S.

4 SITE CONFIGURATION  
SCALE: N.T.S.

**T-Mobile**  
Get more from life!  
10000 SHERMAN AVENUE  
DENVER, CO 80231

**RLS**  
REGENT LAND SERVICES  
CONSULTING GROUP  
1998 W. HAYWARD AVENUE, SUITE 200  
PACIFIC PALMS, CA 91764-7300  
TEL: 714.281.0045  
WWW.RLS-CORP.COM

NO.	DATE	DESCRIPTION	BY
8	04/12/17	ISSUE CD	LR
9	04/12/17	ISSUE CD	LR
1	01/21/18	DSH COMMENTS	BP

PROJECT INFORMATION:  
IE04228A  
SB228 DON LUGO  
HIGH SCHOOL  
1508 PIPELINE AVENUE  
ORANGE CALIFORNIA  
684  
SAN DIEGO COUNTY  
SEAL



SHEET TITLE:  
**ANTENNA GROUNDING AND DETAIL**

SHEET NUMBER:  
**E-1**

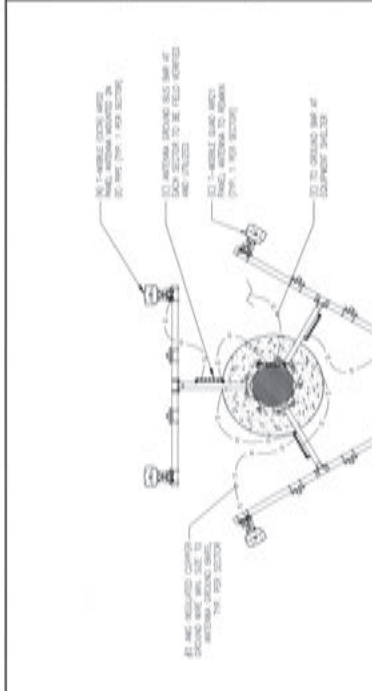

NO.	DESCRIPTION	SCALE	DATE
1	ANTENNA GROUNDING	SCALE	DATE

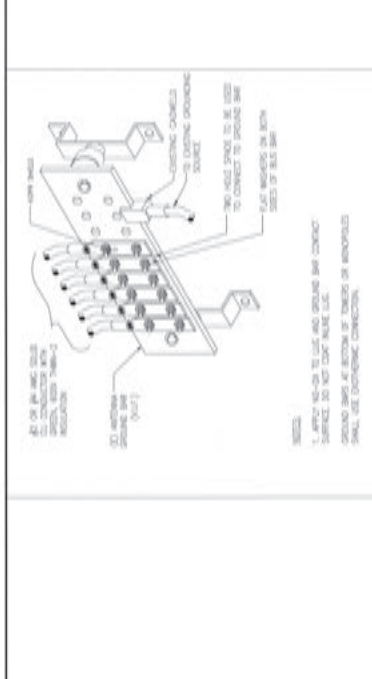

NO.	DESCRIPTION	SCALE	DATE
2	ANTENNA GROUNDING	SCALE	DATE

NOT USED	6	GROUND WIRE INSTALLATION	3
----------	---	--------------------------	---

NOT USED	7	NOT USED	4
----------	---	----------	---

NOT USED	8	NOT USED	5	NOT USED	2
----------	---	----------	---	----------	---

DESIGNER/ENGINEER:  
DATE: 11/11/17  
NO. 15117  
DATE: 11/11/17

**EXHIBIT "B"**  
**INSPECTION SERVICES**





May 7, 2018

Chino Valley Unified School District  
 Attn: James Costa  
 5130 Riverside Drive  
 Chino, CA 91710

**REFERENCE: ESTIMATED COST PROPOSAL – DSA INSPECTION FOR T-MOBILE CELL TOWER UPGRADES AT DON LUGO HIGH SCHOOL  
 DSA No. 03-116987**

Dear Mr. Costa,

TYR, Inc. is honored to submit an estimated pricing proposal to Chino Valley Unified School District for inspection services for the above-mentioned project.

The following estimated proposal is based upon the expected duration of thirty (30) calendar days. With a Project Inspector and hourly rate of \$83.00, the projected estimated cost of inspection services is \$6,972.00. (This estimate excludes overtime, off hours and legal holidays).

Please refer to the table below for the monthly breakdown:

T-Mobile Cell Tower Upgrades at Don Lugo High School				
Duration	Calendar Days	Working Days	Hours	Cost
14-May-18	18	13	52	\$4,316.00
12-Jun-18	12	8	32	\$2,656.00
<b>Total Estimate</b>	<b>30</b>	<b>21</b>	<b>84</b>	<b>\$6,972.00</b>

If there is any additional information you may need, please do not hesitate to call.

Best regards,

Youssef Sobhi  
 President and Senior Inspector

**CHINO VALLEY UNIFIED SCHOOL DISTRICT**

**Our Motto:**

Student Achievement • Safe Schools • Positive School Climate  
Humility • Civility • Service

**DATE:** June 28, 2018

**TO:** Members, Board of Education

**FROM:** Wayne M. Joseph, Superintendent

**PREPARED BY:** Lea Fellows, Assistant Superintendent, Human Resources  
Suzanne Hernandez, Ed.D., Director, Human Resources  
Richard Rideout, Director, Human Resources

**SUBJECT: CERTIFICATED/CLASSIFIED PERSONNEL ITEMS**

=====

**BACKGROUND**

Board approval of personnel transactions is required by Board Bylaw 9324 Bylaws of the Board - Minutes and Recordings and Education Code 35163. Included are new hires based on need, which includes replacements, growth, and/or class size reduction.

Approval of this item supports the goals identified within the District's Strategic Plan.

**RECOMMENDATION**

It is recommended the Board of Education approve/ratify the certificated/classified personnel items.

**FISCAL IMPACT**

All personnel assignments are within the approved staffing ratio for the appropriate school year budget.

WMJ:LF:SH:RR:mcm



**CERTIFICATED PERSONNEL**

<b><u>NAME</u></b>	<b><u>POSITION</u></b>	<b><u>LOCATION</u></b>	<b><u>EFFECTIVE DATE</u></b>
--------------------	------------------------	------------------------	------------------------------

**CERTIFICATED MANAGEMENT PERSONNEL FOR THE 2017/2018 SCHOOL YEAR****RETIREMENT**

VASQUEZ, Rigoberto (19 years of service)	Principal – Continuation	Buena Vista HS	06/22/2018
---	--------------------------	----------------	------------

**CERTIFICATED PERSONNEL FOR THE 2017/2018 SCHOOL YEAR****RETIREMENT**

BREMER, Robert (34 years of service)	PE Teacher	Buena Vista HS	06/04/2018
MARTINEZ, Richard (18 years of service)	Math Teacher	Chino HS	06/02/2018
MOORE, Larry (15 years of service)	PE Teacher	Chino Hills HS	06/02/2018

**RESIGNATION**

HIDALGO, Cynthia	Learning Center Teacher	Borba ES	06/02/2018
CHARLSON, Rhonda	Elementary Teacher	Eagle Canyon ES	06/30/2018
ALVAREZ, Ashley	Elementary Teacher	Rolling Ridge ES	06/13/2018
HWANG, Kyu Ree	Special Education Teacher	Briggs K-8	06/01/2018
HERRERA, Katherine	Science Teacher	Magnolia JHS	06/13/2018
LOWE, Maxwell	Band Teacher	Ayala HS	07/01/2018
REAMS, Robert	Special Education Teacher	Ayala HS	06/30/2018

**APPOINTMENT - EXTRA DUTY**

BRIGGS, Gary (NBM)	Band (B)	Ayala HS	06/29/2018
BUI, Victor (NBM)	Band (B)	Ayala HS	06/29/2018
DURAN, Elliott (NBM)	Band (B)	Ayala HS	06/29/2018
FLOWERS, Charles (NBM)	Football (B)	Ayala HS	06/29/2018
IBARRA, Ana (NBM)	Band (B)	Ayala HS	06/29/2018
WROTH, Christen (NBM)	Band (B)	Ayala HS	06/29/2018
CONDE, Alejandra (NBM)	Band (B)	Chino HS	06/29/2018
GEORGE Sr., Miles (NBM)	Football (B)	Chino HS	06/29/2018
SUVIATE, Alexandra (NBM)	Dance (B)	Chino Hills HS	06/29/2018
VELA, Oscar (NBM)	Boys Basketball (B)	Chino Hills HS	06/29/2018
YAMASAKI, Kyle (NBM)	Dance (B)	Chino Hills HS	06/29/2018

**CERTIFICATED PERSONNEL** (cont.)

<b><u>NAME</u></b>	<b><u>POSITION</u></b>	<b><u>LOCATION</u></b>	<b><u>EFFECTIVE DATE</u></b>
--------------------	------------------------	------------------------	------------------------------

**APPOINTMENT – SUMMER SCHOOL TEACHERS**

VALENZUELA, Benito	5 <sup>th</sup> Grade/6 <sup>th</sup> Grade	Litel ES	06/08/2018
ROY, Alex	Math	Buena Vista HS	06/08/2018
GREEN, Greg	Integrated Math 1	Chino HS	06/27/2018
PHUNG, Than Truyen	Integrated Math 1	Chino HS	06/08/2018
SANDOVAL, Salvador	Biology CP	Chino HS	06/08/2018
TATUM, Esmeralda	Biology CP	Chino HS	06/08/2018
VIRAMONTES DORADO, Fernando	Integrated Math 1	Chino Hills HS	06/08/2018
VIRAMONTES DORADO, Fernando	Integrated Math 2	Chino Hills HS	06/27/2018

**DELETE - SUMMER SCHOOL TEACHERS**

MORSE, Karen	5 <sup>th</sup> Grade	Litel ES	06/08/2018
CHOI, Alice	Math	Buena Vista HS	06/08/2018
VIRAMONTES DORADO, Fernando	Integrated Math 3	Chino HS	06/08/2018

**APPOINTMENT – SUMMER SCHOOL TEACHER – EXTENDED SCHOOL YEAR**

HENDERTILO, Rachel	Autism 5 <sup>th</sup> – 6 <sup>th</sup> Grade	Litel ES	06/20/2018
RICHARD, Teresa	M/M 4 <sup>th</sup> – 6 <sup>th</sup> Grade	Litel ES	06/18/2018

**DELETE – SUMMER SCHOOL TEACHER – EXTENDED SCHOOL YEAR**

BERGMANN, James	M/M 4 <sup>th</sup> – 6 <sup>th</sup> Grade	Litel ES	06/18/2018
DELORIA, Denise	Autism 5 <sup>th</sup> – 6 <sup>th</sup> Grade	Litel ES	06/20/2018

**HIRED AT APPROPRIATE PLACEMENT ON THE CERTIFICATED SALARY SCHEDULE AND APPROPRIATE CREDENTIAL FOR THE 2018/2019 SCHOOL YEAR**

EDWARDS, Kaitlyn	Elementary Teacher	Eagle Canyon ES	08/07/2018
RUSSELL, Cheryl	Special Education Teacher	Eagle Canyon ES	08/07/2018
VEENSTRA, Victoria	Elementary Teacher	Dickson ES	08/07/2018
IOSSIF, Italia	Special Education Teacher	Canyon Hills JHS	08/07/2018
ANDRADE, Karina	Art Teacher	Magnolia JHS	08/07/2018
POPOCA, Victor	Math Teacher	Ramona JHS	08/07/2018
RICHARDS, Brittnie	Special Education Teacher	Ramona JHS	08/07/2018
ESSIG, Kristyn	Special Education Teacher	Woodcrest JHS	08/07/2018
ARNELL, Derek	Computer Teacher	Ayala HS	08/07/2018
GANCZ, Gerado	Spanish Teacher	Ayala HS	08/07/2018
KAVIA, Shital	Biology Teacher	Ayala HS	08/07/2018
MYERS, Paige	Special Education Teacher	Ayala HS	08/07/2018

**CERTIFICATED PERSONNEL** (cont.)

<b><u>NAME</u></b>	<b><u>POSITION</u></b>	<b><u>LOCATION</u></b>	<b><u>EFFECTIVE DATE</u></b>
<b><u>HIRED AT APPROPRIATE PLACEMENT ON THE CERTIFICATED SALARY SCHEDULE AND APPROPRIATE CREDENTIAL FOR THE 2018/2019 SCHOOL YEAR</u></b> (cont.)			
SANDEL, Alexandria	Intervention Counselor	Ayala HS	07/25/2018
TROST, Timothy	Band Teacher	Ayala HS	08/07/2018
NEWCOMB, James	Social Science Teacher	Buena Vista HS	08/07/2018
TERRY, Mykeal	Social Science Teacher	Chino Hills HS	08/07/2018
WILLIAMS, Angela	Science Teacher	Chino Hills HS	08/07/2018
LOPEZ, Kenia	School Psychologist	Special Education	08/06/2018
SAITO, Steven	RSP Floater	Special Education	08/07/2018

**CHANGE IN ASSIGNMENT FOR THE 2018/2019 SCHOOL YEAR**

CANDELARIA, Ryan	FROM: Principal – ES TO: Assistant Principal	Newman ES CVLA	07/01/2018
------------------	---	-------------------	------------

**APPOINTMENT OF CERTIFICATED SUBSTITUTES EFFECTIVE JULY 1, 2018 THROUGH JUNE 30, 2019**

AHMAD, Sadia	ARGUELLO, Patricia	BARRINGTON AKAUOLA, Elizabeth
BARTHOLIO, Carol	BURDA, Kristen	CEPEDA, Jesus
CHAVEZ, Jr., Agustin	DAVID, Breanna	DINSMOOR, Danielle
DONEGAN, Sherrie	FRANCO, Lilia	GISHWILLER, Thomas
GRAHAM, Debra	GUPTA, Parag	HARBAUGH, John
HARGROVE, Jennifer	HENDERTILO, Rachel	HILL, Rebecca
HIRCHAG, Nancy	HOWARD, Carole	JAIME, Nicole
JARA, Priscilla	JEWETT, Michelleann	JOHNSON, Ashley
KERTESZ, Celeste	KUHN, Candace	MACKESSY, Linda
MACKESSY, Stephen	MACKEY, Jeffie	MALDONADO, Mariana
MATTHEWS, Jennifer	MATTSON, Amy	MCLEOD, Marsha
MCPHEETERS, Zelma	MILLER, Jeffrey	MINTON, Eileen
MOET, Camille	MORGAN, Janet	MOSQUEDA, Ashley
MUNOZ, Elena	MUNOZ, Jorge	NIOTTA, Skyler
NUNEZ, Tania	OWENS, Jonathan	PARKER, Grant
PARRELL, Jessica	PEARL, Vicki	PERSON, Tricia
PETERSON, Rebecca	PIKE, William	PIRES, Betty
PONNALURI, Sirisha	POTTER, Harold	PRESCOTT, Janet
PRIETO, Gabriel	QUINN, Ryan	RAMIREZ, Sharon
RAMIREZ, Yessenia	RANASINGHE, Kishor	RIVERA, Jennie
ROY, Alex	SCHNEIDER, Gena	SCHULTZ, Mary
SHEEHAN, Amanda	SHELBY, Whitney	SOSA, Frankie

**CERTIFICATED PERSONNEL** (cont.)

<b><u>NAME</u></b>	<b><u>POSITION</u></b>	<b><u>LOCATION</u></b>	<b><u>EFFECTIVE DATE</u></b>
--------------------	------------------------	------------------------	------------------------------

**APPOINTMENT OF CERTIFICATED SUBSTITUTES EFFECTIVE JULY 1, 2018 THROUGH JUNE 30, 2019**

STOEHR, Conchita	SURINA, Patrick	TAN, Celine
TUMMINELLI, August	VALERO, Jennifer	VERDUSCO, Alexandra
WAITE, Madison	WALLACE, Rhonda	YARDLEY, Lorraine
YOUNG, Devan	YSAIS-PORTUGAL, Catherine	YU, Frank
ZENDEJAS-LUGO, Claudia		

**CLASSIFIED PERSONNEL**

<b><u>NAME</u></b>	<b><u>POSITION</u></b>	<b><u>LOCATION</u></b>	<b><u>EFFECTIVE DATE</u></b>
--------------------	------------------------	------------------------	------------------------------

**HIRED AT THE APPROPRIATE PLACEMENT ON THE CLASSIFIED MANAGEMENT SALARY SCHEDULE**

**APPOINTMENT**

AULD-WRIGHT, Kelly	Occupational Therapist (SELPA/GF)	Special Education	08/06/2018
--------------------	--------------------------------------	-------------------	------------

**HIRED AT THE APPROPRIATE PLACEMENT ON THE CLASSIFIED SALARY SCHEDULE**

**APPOINTMENT**

FRAUSTO, Corrie	Elem. Lib. Media Ctr. Asst. (GF)	Litel ES	08/14/2018
CHRISTENSON, Alyia	Nutrition Services Asst. I (NS)	Oak Ridge ES	08/10/2018
ALVARADO, Patricia	Nutrition Services Asst. I (NS)	Cal Aero K-8	07/02/2018
RUBIO, Alejandro	Custodian II (GF)	Chino Hills HS	07/02/2018
SMITH, Bodie	Network Technician (GF)	Technology	07/02/2018

**AMENDMENT TO APPOINTMENT DATE ON JUNE 14, 2018 BOARD AGENDA**

LOURENCO, Johnny	Custodian I (GF)	Adult School	07/02/2018
------------------	------------------	--------------	------------

**PROMOTION**

ORIHUELA, Diana	FROM: Bilingual Typist Clerk I (GF) 3.5 hrs./200 work days TO: Typist Clerk II (GF) 8 hrs./201 work days	Briggs K-8  Ayala HS	08/01/2018
-----------------	--	----------------------------	------------

**INCREASE HOURS/DAYS**

DEBACA, Anacani	FROM: Bus Driver (GF) 5.5 hrs./183 work days TO: Bus Driver (GF) 6 hrs./183 work days and 4 hrs./25 work days	Transportation  Transportation	07/02/2018
GARCIA, Nora	FROM: Bus Driver (GF) 6 hrs./183 work days TO: Bus Driver (GF) 6 hrs./183 work days and 4 hrs./25 work days	Transportation  Transportation	07/02/2018

**CLASSIFIED PERSONNEL** (cont.)

<b><u>NAME</u></b>	<b><u>POSITION</u></b>	<b><u>LOCATION</u></b>	<b><u>EFFECTIVE DATE</u></b>
--------------------	------------------------	------------------------	------------------------------

**INCREASE HOURS/DAYS** (cont.)

RAMIREZ, Regina	FROM: Bus Driver (GF) 5.5 hrs./183 work days	Transportation	08/09/2018
	TO: Bus Driver (GF) 6 hrs./183 work days	Transportation	

**CHANGE IN ASSIGNMENT**

GIBSON, Erin	FROM: School Secretary II (GF) 8 hrs./225 work days	Ayala HS	07/01/2018
	TO: School Secretary I (GF) 8 hrs./261 contract days	Alternative Ed.	

RODRIGUEZ, Gloria	FROM: IA/Special Education (SELPA/GF) 3.5 hrs./181 work days	Ayala HS	08/01/2018
	TO: Typist Clerk I (GF) 8 hrs./201 work days	Ayala HS	

CUCALON, Koreena	FROM: Grant Program Support Spec. (C) 8 hrs./190 work days	Health Services	08/02/2018
	TO: Grant Program Support Spec. (C) 8 hrs./204 work days	Health Services	

**EXERCISED DISPLACEMENT RIGHTS DUE TO LAYOFF**

DEL VILLAR, Linda	IA/Special Ed. (SELPA/GF)	Newman ES	07/01/2018
-------------------	---------------------------	-----------	------------

**RESIGNATION**

SOTELO, Nicole	IA/Bilingual-Biliterate ASL (GF)	Don Lugo HS	06/01/2018
HERNANDEZ MACEDO, Laura	Behavior Intervention Aide (SELPA/GF)	Special Education	06/14/2018

**RETIREMENT**

ALARCON, Barbara (35 years of service)	IA/Biling.-Bilit. Spanish (C)	Newman ES	07/01/2018
HUGHES, Linda (24 years of service)	Admin. Secretary I CSEA (GF)	Assess. & Instructional Tech.	09/01/2018

**CLASSIFIED PERSONNEL** (cont.)

<b><u>NAME</u></b>	<b><u>POSITION</u></b>	<b><u>LOCATION</u></b>	<b><u>EFFECTIVE DATE</u></b>
<b><u>RETIREMENT</u></b> (cont.)			
PENNER, Mark (34 years of service)	Programmer Analyst (GF)	Technology	07/05/2018

**APPOINTMENT OF CLASSIFIED SUBSTITUTES EFFECTIVE JULY 1, 2017, THROUGH JUNE 30, 2018**

CAMPOS, Evelyn                      FJELDSTED, Danielle

**APPOINTMENT OF SHORT TERM EMPLOYEES EFFECTIVE JULY 1, 2018, THROUGH DECEMBER 31, 2018**

REYES, Maria                      IA/Special Ed/SH                      Cal Aero  
WAKE, Alyssa                      IA/Special Ed – Collab.              Cal Aero

**APPOINTMENT OF CLASSIFIED SUBSTITUTES EFFECTIVE JULY 1, 2018, THROUGH JUNE 30, 2019**

BAEZA, Mario	BARILLA, Veronica	BARRIOS, Ronni
BAYONA, Karen	BOTELLO, Jessica	BRIONES, Steven
CAMPOS, Evelyn	CARMONA, Sindia	CARTER, Samantha
CISNEROS, Pamela	CONRARDY, Victoria	DE MARCO, Janelle
DELGADO, Linda	DRUMMOND, Pamela	FJELDSTED, Danielle
FONTAN, Veronica	FRAUSTO, Mario	GARCIA, Marcial
GARCIA, Nereida	GARZA, Lisa Marie	GONZALES Jr., Steven
GONZALEZ, Maria	GONZALEZ, Martin	GONZALEZ, Matthew
GORDON, Diane	GUARACHA, Erma	GUTIERREZ, Lacey
HALL, Cindy	HERRERA, Lucy	HOENISCH, Susan
HORN, Sheila	JOHNSTON-AU, Theresa	KAO, Karen
KEIR, Barbara	LIVINGSTON, Luci	LOERA, Bertha
LUCAS, John	MAGALLANES, David	MARTINEZ, John
MCNABB, Kyle	MEZA, Mary	MOHLMAN, Tyler
MORENO, Rosalie	MUNOZ, Andrew	MUNOZ, Yizel
NAKASAKI, Nadine	OLIVA, Amparo	OROSCO, Anthony
PALMER, Anne	PAPPAS, Beatrice	REYES, Maria
REYNOSO, Gregorio	REZK, Adam	ROCHA, Ashlie
ROCHA, Devon	ROCHA, Iris	ROJAS Jr., Rafael
ROMERO, Soledad	ROSALEZ Jr., Victor	SALAZAR, Sandra
SALDANA, Vanessa	SANCHEZ, Virnie	SOTO, Beatrice
TOWNSELL, Brandy	TRUJILLO, Jocelyn	VILLARREAL, Cynthia

**CLASSIFIED PERSONNEL** (cont.)

<b><u>NAME</u></b>	<b><u>POSITION</u></b>	<b><u>LOCATION</u></b>	<b><u>EFFECTIVE DATE</u></b>
--------------------	------------------------	------------------------	------------------------------

**APPOINTMENT OF CLASSIFIED SUBSTITUTES EFFECTIVE JULY 1, 2018, THROUGH JUNE 30, 2019**

VIS, Cathy	WARD, Claudia	WILLIAMS, Tramaine	
YAMAS-ALONZO, Andrea	YORBA LIRA, Elena		

- (504) = Federal Law for Individuals with Handicaps
- (ACE) = Ace Driving School
- (ABG) = Adult Education Block Grant
- (ASB) = Associated Student Body
- (ASF) = Adult School Funded
- (ATE) = Alternative to Expulsion
- (B) = Booster Club
- (BTSA) = Beginning Teacher Support & Assessment
- (C) = Categorically Funded
- (CAHSEE) = California High School Exit Exam
- (CC) = Children's Center (Marshall)
- (CDF) = Child Development Fund
- (CSR) = Class Size Reduction
- (CVLA) = Chino Valley Learning Academy
- (CWY) = Cal Works Youth
- (E-rate) = Discount Reimbursements for Telecom.
- (G) = Grant Funded
- (GF) = General Fund
- (HBE) = Home Base Education
- (MM) = Measure M – Fund 21
- (MAA) = Medi-Cal Administrative Activities
- (MH) = Mental Health – Special Ed.
- (NBM) = Non-Bargaining Member
- (ND) = Neglected and Delinquent
- (NS) = Nutrition Services Budget
- (OPPR) = Opportunity Program
- (PFA) = Parent Faculty Association
- (R) = Restricted
- (ROP) = Regional Occupation Program
- (SAT) = Saturday School
- (SB813) = Medi-Cal Admin. Activities Entity Fund
- (SELPA) = Special Education Local Plan Area
- (SOAR) = Students on a Rise
- (SPEC) = Spectrum Schools
- (SS) = Summer School
- (SWAS) = School within a School
- (VA) = Virtual Academy
- (WIA) = Workforce Investment Act



**CHINO VALLEY UNIFIED SCHOOL DISTRICT**

**Our Motto:**

Student Achievement • Safe Schools • Positive School Climate  
Humility • Civility • Service

**DATE:** June 28, 2018

**TO:** Members, Board of Education

**FROM:** Wayne M. Joseph, Superintendent

**PREPARED BY:** Lea Fellows, Assistant Superintendent, Human Resources  
Craig Frame, Director, Risk Management and Human Resources

**SUBJECT: REJECTION OF CLAIMS**

=====

**BACKGROUND**

Claim 18-06-10 was submitted on June 5, 2018, by Livanya Lee on behalf of her son, a student at Chaparral ES. Claimant alleges emotional damages under state and federal regulations. Claimant seeks reimbursement for emotional damages in the amount of \$570,000.00.

Claim 18-06-11 was submitted on June 12, 2018, by Timothy P. Prince, LLP on behalf of Irene Hernandez-Blair and her son, a student at Don Lugo HS. Claimant alleges sexual assault, humiliation, emotional distress, and sexual harassment that occurred during the 2017/2018 school year. Claimant seeks unspecified damages and seeks a settlement demand that lies within the jurisdiction of the Superior Court.

Claim 18-06-12 was submitted on June 12, 2018, by Timothy P. Prince, LLP on behalf of Corina Talamantes and her son, a student at Don Lugo HS. Claimant alleges sexual assault, humiliation, emotional distress, and sexual harassment that occurred during the 2017/2018 school year. Claimant seeks unspecified damages and seeks a settlement demand that lies within the jurisdiction of the Superior Court.

Claim 18-06-13 was submitted on June 13, 2018, by Michael Chu, a member of the public. Claimant alleges discrimination, denial of equal opportunity and access for schooling, which violates California Education Code. Claimant seeks reimbursement for damages in the amount of \$7,000.00.

The Board is requested to reject claims against the District to allow insurance carriers to investigate the claims and make recommendations regarding the dispositions.

Approval of this item supports the goals identified within the District's Strategic Plan.

## **RECOMMENDATION**

It is recommended the Board of Education reject the claims and refer them to the District's insurance adjuster.

## **FISCAL IMPACT**

Unknown at present.

WMJ:LF:CF:lag

**CHINO VALLEY UNIFIED SCHOOL DISTRICT**

**Our Motto:**

Student Achievement • Safe Schools • Positive School Climate  
Humility • Civility • Service

**DATE:** June 28, 2018

**TO:** Members, Board of Education

**FROM:** Wayne M. Joseph, Superintendent

**PREPARED BY:** Lea Fellows, Assistant Superintendent, Human Resources  
Suzanne Hernandez, Ed. D., Director, Human Resources  
Richard Rideout, Director, Human Resources

**SUBJECT: REVISIONS TO THE JOB DESCRIPTIONS FOR ASSISTANT SUPERINTENDENT, BUSINESS SERVICES; ASSISTANT SUPERINTENDENT, CURRICULUM, INSTRUCTION, INNOVATION, AND SUPPORT; ASSISTANT SUPERINTENDENT, FACILITIES, PLANNING AND OPERATIONS; AND ASSOCIATE SUPERINTENDENT, EDUCATIONAL SERVICES**

=====

**BACKGROUND**

Job descriptions are a statement of duties, qualifications, and responsibilities associated with a particular job. It is a matter of standard practice to modify and/or create job descriptions as new positions become necessary, jobs evolve, and responsibilities and duties change. Additionally, changes in organizational structure, student needs, and other factors require the revision of existing positions to support the District’s mission of increased student achievement.

The restructuring and reorganization of key positions are needed to meet the strategic goals and vision of the Chino Valley Unified School District Board of Education.

New language is provided in UPPER CASE.

Approval of this item supports the goals identified within the District’s Strategic Plan.

**RECOMMENDATION**

It is recommended the Board of Education approve the revisions to the job descriptions for:

- a) Assistant Superintendent, Business Services;
- b) Assistant Superintendent, Curriculum, Instruction, Innovation, and Support;
- c) Assistant Superintendent, Facilities, Planning and Operations; and
- d) Associate Superintendent, Educational Services.

**FISCAL IMPACT**

None.

**CHINO VALLEY UNIFIED SCHOOL DISTRICT**  
**Position Description**

<b>TITLE:</b>	ASSOCIATE <del>Assistant</del> Superintendent, Business Services	<b>REPORTS:</b>	Superintendent
<b>DEPARTMENT:</b>	Business Services	<b>CLASSIFICATION:</b>	Management
<b>FLSA:</b>	Exempt	<b>WORK YEAR:</b>	226
<b>ISSUED:</b>	December 14, 1995	<b>SALARY:</b>	Range 9 <del>42</del>

**BASIC FUNCTION:**

Under the direction of the Superintendent, plans, organizes, manages, and directs all aspects of the District's Business Services, providing leadership to District personnel, with specific responsibility for the planning, development, implementation, assessment, and improvement of all business services in the District, and complying with federal and state laws, and District regulations, policies, and procedures.

**REPRESENTATIVE DUTIES:**

Incumbent may perform any combination of the essential functions shown below. This position description is not intended to be an exhaustive list of all duties, knowledge, or abilities, associated with this classification but is intended to accurately reflect the principle job elements.

**E = ESSENTIAL FUNCTIONS**

Provides leadership and direction in the identification and interpretation of needs and the establishment of priorities related to Business Services (accounting, budgeting, finance, nutrition services and payroll); initiates and assists in coordinating the planning, development and implementation of programs and activities designed to meet such needs and priorities. **(E)**

OVERSEES ALL ASPECTS OF THE DISTRICT'S BOND PROGRAM, PROVIDES DIRECTION TO THE ASSISTANT SUPERINTENDENT OF FACILITIES, PLANNING & OPERATION IN CARRYING OUT THE WORK OF THE BOND. **(E)**

Plans, organizes, and directs Business Services design and programs, delivery systems, strategies and techniques for achieving optimal educational results. **(E)**

Coordinates those staff development programs with District and school site staff which relates to the implementation of Business Service priorities. **(E)**

Works collaboratively with the District's management team and other administrators to ensure the coordination, alignment, and articulation of a comprehensive educational services/instructional program pre-K-12 that meets the needs of the diverse student population of the District. **(E)**

Develops, implements, and evaluates goals and objectives as they pertain to the business needs of the District as directed. **(E)**

Reviews, proposes, monitors, and informs staff and community of legislation affecting fiscal management and projected financial needs. **(E)**

Ensures consistent and efficient management of all District financial functions within applicable law. **(E)**

Coordinates the functions of business services with the Division of Human Resources, and other departments of the District as necessary.

Ensures the handling of receipts and disbursement of funds are separate from the accounting function. **(E)**

Directs and coordinates the preparation of the District's annual budget at the direction of the Superintendent in cooperation with other managers and personnel. **(E)**

Provides the District's chief negotiator or negotiation team with financial information relative to the collective bargaining process. **(E)**

Responsible for the success of the District's independence as a "fiscally accountable" District and meeting all requirements in this regard. **(E)**

Assures the District's financial records are accurate and in compliance with county, state, and federal legal and auditor guidelines. **(E)**

Establishes a climate within the Division of Business Services that is conducive to appropriate conduct, performance, attitude, job satisfaction, and service oriented. **(E)**

Maintains an updated, current working knowledge of and provides the management team with assistance in the interpretation and application of statutes and regulations which deal with accounting, budgeting, finance, nutrition services, and payroll. **(E)**

Develops, evaluates, and makes recommendations to the Superintendent regarding District policies as they pertain to the business needs of the District, and provides interpretation of District policies and procedures, ensuring compliance with all federal and state laws, regulations and policies. **(E)**

Follows a planned professional growth program, participates actively in local, state, and national professional associations/organizations; and studies local, state, and national guidelines for effective business service.

Directs the development and approves the departmental budget for assigned areas of responsibility. **(E)**

Functions as a member of the District's management team, coordinates with other management personnel in the areas of assigned responsibility. **(E)**

Supervises and evaluates the performance of assigned staff; interviews and selects employees, and recommends transfers, reassignments, terminations, and disciplinary actions; plans, coordinates, and arranges for appropriate training of subordinates. **(E)**

Directs the preparation and maintenance of a variety of narrative and statistical reports (including county, state and federal reports as required), records, and files; prepares agendas and memos; and, maintains all documentation reflecting agreements entered into by the Division of Business Services. **(E)**

Develops and implements long- and short-term plans and activities to anticipate and accommodate the District's projected financial needs in an efficient and effective manner, and to ensure compliance with the District policies, Education Code, and state and federal regulations and laws in an efficient and effective manner. (E)

Assures accurate and timely dissemination of information. (E)

Serves on committees such as the District's management team and other committees as appropriate or assigned by immediate supervisor. (E)

Represents the District as a liaison in meeting with county/state/federal agencies, institutions, and committees that are related to areas of responsibility as assigned. (E)

Represents the District, when so assigned in social, organizational, ceremonial, political, or other functions.

Keeps informed of current trends in theory and practices of assigned areas of responsibility, and other pertinent areas, such as federal, state and local laws and District regulations, policies, and procedures, and assures that administration is kept aware of such matters. (E)

Provides leadership and expertise in forming, guiding, and counseling District committees, groups, councils, and advisories for assigned areas of responsibility, providing leadership, support, and guidance to staff and members of the community to ensure thorough communication relative to the educational design and delivery process. Also ensures that community advisory groups have the opportunity to participate in the processes of assessment and evaluation of Business Services. (E)

Attends all Board of Education meetings. (E)

Performs all other duties as assigned.

#### **MINIMUM REQUIREMENTS:**

#### **EDUCATION, EXPERIENCE, LICENSES, AND OTHER REQUIREMENTS:**

Bachelor's degree is required. Master's degree in business or public administration, accounting, finance, or related field is required. Doctoral degree in related field is preferred.

Completion of courses in school fiscal administration and education is desirable. A minimum of five (5) years experience in business management and/or other job related occupation is required. Experience working directly with public school districts is desirable. Or, a minimum of five (5) years of experience in the area of school finance. Demonstrated experience in the areas of budget development and control; payroll systems; accounting systems; purchasing procedures; warehouse inventory and control; transportation systems; and nutrition services is desirable.

Employment eligibility that may include fingerprints, health (TB), and/or other employment clearance.

Must have valid California driver's license and automobile available for use. Must be willing to attend evening, night, and weekend meetings.

## **KNOWLEDGE AND ABILITIES:**

### **KNOWLEDGE OF:**

- Philosophical, educational, fiscal, and legal aspects affecting school business management;
- Governmental budgeting, accounting, purchasing, stores, insurance, and contracts;
- Research methods and report writing techniques;
- Audit and fiscal control procedures;
- District's educational and instructional objectives;
- District organization, operations, policies, and procedures;
- Technical aspects of field of specialty;
- Principles of organization, operation, and supervision;
- Principles, practices, trends, goals, and objectives of public education and assigned areas of responsibility;
- Modern technology and office procedures and methods, computer equipment, and computer software necessary to perform required duties;
- Budget preparation and control;
- Applicable federal, state, and local laws, codes, regulations, policies, and procedures related to assigned activities; AND
- Oral and written communication skills, including English usage, grammar, spelling, punctuation, vocabulary, composition, and mathematics.

### **ABILITY TO:**

- Plan, organize, and administer a comprehensive business services program;
- Analyze financial statements and fiscal reports and prepare a complex budget based on valid assumptions within stated guidelines;
- Administer assigned budgets and allocate funds;
- Demonstrate leadership qualities and utilize motivational techniques and strategies in the development of an operational mode that is cost effective;
- Operate a computer terminal and audio-visual equipment;
- Operate computer applications for complex financial management and position control management;
- Communicate effectively, both orally and in writing;
- Write in a clear and concise manner for broad public appeal and interpretation.
- Gain cooperation through discussion and persuasion;
- Coordinate and supervise the work of others;
- Analyze situations carefully and adopt an effective course of action;
- Interpret, apply, and explain administrative and Board policies, laws, regulations, and collective bargaining agreements that pertain to assigned areas of responsibility;
- Plan, organize, and prioritize work to meet multiple schedules and deadlines, and manage simultaneous tasks, with many interruptions;
- Work independently with minimum direction and supervision; work under pressure;
- Understand, analyze, and prepare comprehensive, narrative and statistical reports;
- Establish and maintain cooperative and effective working relationships with District personnel, community members, and external companies and agencies in the course of performing assigned duties; AND
- Supervise and evaluate the performance of assigned staff.

**WORKING CONDITIONS:**

**ENVIRONMENT:**

- District office environment and school sites;
- Demanding timelines;
- Subject to driving to a variety of locations to conduct work during day and evening hours;
- Subject to frequent interruptions and extensive contact with students, staff, parents, and the public; AND
- Indoor and outdoor environment.

**PHYSICAL DEMANDS:**

- Bending at the waist, kneeling or crouching, and reaching to retrieve and maintain files and records;
- Reaching overhead, above the shoulders and horizontally;
- Dexterity of hands and fingers to operate standard office equipment, computer keyboard, and other equipment necessary to complete the required duties;
- Hearing and speaking to exchange information in person and on the telephone;
- Visual ability to read, and to prepare/process documents and to monitor various services and personnel;
- Sitting for extended periods;
- Standing for extended periods;
- Walking over rough or uneven surfaces;
- Climbing, occasional use of stepladders; AND
- Physical activity may be required, which could include moderate lifting.

**HAZARDS:**

- Extended viewing of computer monitor; AND
- Working around and with office equipment having moving parts.

---

I have read the above position description and fully understand the requirements set forth therein. I hereby accept the position of ~~Assistant~~ ASSOCIATE Superintendent, Business Services and agree to abide by the requirements and duties set forth. I will perform all duties and responsibilities to the best of my ability.

---

(Signature of Employee)

---

(Date)

In compliance with the Americans with Disabilities Act, the Chino Valley Unified School District will provide reasonable accommodations to qualified individuals with disabilities, and encourages both prospective and current employees to discuss potential accommodations with the Division of Human Resources.

Board Approved: December 14, 1995  
REVISED:



**CHINO VALLEY UNIFIED SCHOOL DISTRICT**  
**Position Description**

<b>TITLE:</b>	Assistant Superintendent, Curriculum, Instruction, Innovation, and Support	<b>REPORTS:</b>	Superintendent
<b>DIVISION:</b>	Curriculum, Instruction, Innovation, and Support	<b>CLASSIFICATION:</b>	Management
<b>FLSA:</b>	Exempt	<b>WORK YEAR:</b>	226
<b>ISSUED:</b>	June 29, 2009	<b>SALARY:</b>	Range 12

**BASIC FUNCTION:**

Under the direction of the Superintendent AND ASSOCIATE SUPERINTENDENT, plans, organizes, manages, and directs all aspects of Curriculum, Instruction, Innovation, and Support (Alternative Education, Assessment and Instructional Technology, Elementary and Secondary Curriculum AND INSTRUCTION, Health Services/CHILD DEVELOPMENT, Professional Development, Special Education, Student Support Services, and Technology), providing leadership to District personnel, with specific responsibility for the planning, development, implementation, assessment, and improvement of all curriculum and instruction/teaching and learning and educational services in the District, and complying with federal and state laws, and District regulations, policies, and procedures.

**REPRESENTATIVE DUTIES:**

Incumbent may perform any combination of the essential functions shown below. This position description is not intended to be an exhaustive list of all duties, knowledge, or abilities, associated with this classification but is intended to accurately reflect the principle job elements.

**E** = Essential Functions

Provides leadership and direction in the identification and interpretation of needs and the establishment of priorities related to the District's curriculum and instruction/teaching and learning and educational services initiates and assists in coordinating the planning, development and implementation of programs and activities designed to meet such needs and priorities. **(E)**

Plans, organizes, and directs the District's curriculum and instruction/teaching and learning and educational services design and development programs, delivery systems, strategies and techniques for achieving optimal educational results. **(E)**

Coordinates those staff development programs with District and school-site staff which relate to the implementation of curriculum and instruction/teaching and learning and educational services priorities. **(E)**

Analyzes performance test results for students; analyzes corresponding District curriculum and instruction/teaching and learning and educational services for effectiveness in improving students' achievement. (E)

Establishes a climate within the Division of Curriculum, Instruction, Innovation, and Support that is conducive to appropriate conduct, performance, attitude, job satisfaction, and service orientation. (E)

Maintains an updated, current working knowledge of and provides the management team with assistance in the interpretation and application of statutes and regulations which deal within the Division of Curriculum, Instruction, Innovation, and Support. (E)

Develops, evaluates, and makes recommendations to the Superintendent AND ASSOCIATE SUPERINTENDENT, regarding District policies as they pertain to the needs of the Division of Curriculum, Instruction, Innovation, and Support, and provides interpretation of District policies and procedures, ensuring compliance with all federal and state laws, regulations and policies. (E)

Follows a planned professional growth program, participates actively in local, state, and national professional associations/organizations; and studies local, state, and national guidelines for effective services.

~~Directs the development and approves the departmental budget for assigned areas of responsibility. (E)~~

Functions as a member of the District's management team, coordinates with other management personnel in the areas of assigned responsibility. (E)

Supervises and evaluates the performance of assigned staff, interviews and selects employees, and recommends transfers, reassignments, terminations, and disciplinary actions; plans, coordinates, and arranges for appropriate training of subordinates. (E)

Directs the preparation and maintenance of a variety of narrative and statistical reports (including state and federal reports as required), records, and files; prepares agendas and memos; and, maintains all documentation reflecting agreements entered into. (E)

Develops and implements long- and short-term plans and activities to ensure compliance with the District policies, Education Code, and state and federal regulations and laws in an efficient and effective manner. (E)

Assures accurate and timely dissemination of information. (E)

Serves on committees such as the District's management team and other committees as appropriate or assigned by immediate supervisor. (E)

Represents the District as a liaison in meeting with county/state/federal agencies, institutions, and committees that are related to areas of responsibility as assigned.

Represents the District, when so assigned in social, organizational, ceremonial, political, or other functions.

Keeps informed of current trends in theory and practices of assigned areas of responsibility, and other pertinent areas, such as federal, state and local laws and District regulations, policies, and procedures, and assures that administration is kept aware of such matters. (E)

Provides leadership and expertise in forming, guiding, and counseling District committees, groups, councils, and advisories for assigned areas of responsibility, providing leadership, support, and guidance to staff and members of the community to ensure thorough communication relative to the educational design and delivery process.

Attends all Board of Education meetings. **(E)**

Performs all other duties as assigned.

**MINIMUM REQUIREMENTS:**

**EDUCATION, EXPERIENCE, LICENSES, AND OTHER REQUIREMENTS:**

Bachelor's degree is required. Master's degree in educational administration, curriculum and instruction, or related field is required. Doctoral degree in related field is preferred.

Completion of courses in curriculum development and coursework design, within the assigned areas of responsibility is desirable. A minimum of five (5) years experience in curriculum and development and/or other job related occupations is required. Experience working directly with public school districts is required.

Possession of a valid California preliminary or professional clear multiple or single subject teaching credential authorizing service as an elementary or secondary teacher is required.

Possession of a valid California administrative credential authorizing service as an administrator is required.

Employment eligibility that may include fingerprints, health (TB), and/or other employment clearance.

Must have valid California driver's license and automobile available for use. Must be willing to attend evening, night, and weekend meetings.

**KNOWLEDGE AND ABILITIES:**

**KNOWLEDGE OF:**

- Curriculum development, evaluation, and implementation of instructional materials, and measurement and evaluation strategies;
- District's educational and instructional objectives at all grade levels;
- District organization, operations, policies, and procedures;
- Technical aspects of field of specialty;
- Principles of organization, operation, and supervision;
- Principles, practices, trends, goals, and objectives of public education and assigned areas of responsibility;
- Modern technology and office procedures and methods, computer equipment, and computer software necessary to perform required duties;
- Budget preparation and control;
- Applicable federal, state, and local laws, codes, regulations, policies, and procedures related to assigned activities; AND

- Oral and written communication skills, including English usage, grammar, spelling, punctuation, vocabulary, composition, and mathematics.

**ABILITY TO:**

- Plan, organize, and administer a comprehensive educational services program;
- Administer assigned budgets and allocate funds;
- Demonstrate leadership qualities and utilize motivational techniques and strategies in the development of an operational mode that is cost effective;
- Operate a computer terminal and audio-visual equipment;
- Communicate effectively, both orally and in writing;
- Write in a clear and concise manner for broad public appeal and interpretation;
- Gain cooperation through discussion and persuasion;
- Coordinate and supervise the work of others;
- Analyze situations carefully and adopt an effective course of action;
- Interpret, apply, and explain administrative and board policies, laws, regulations, and collective bargaining agreements that pertain to areas of responsibility;
- Plan, organize, and prioritize work to meet multiple schedules and deadlines, and manage simultaneous tasks, with many interruptions;
- Work independently with minimum direction and supervision; work under pressure;
- Understand, analyze, and prepare comprehensive, narrative and statistical reports;
- Establish and maintain cooperative and effective working relationships with District personnel, community members, and external companies and agencies in the course of performing assigned duties; AND
- Supervise and evaluate the performance of assigned staff.

**WORKING CONDITIONS:**

**ENVIRONMENT:**

- District office environment and school sites;
- Demanding timelines;
- Subject to driving to a variety of locations to conduct work during day and evening hours.
- Subject to frequent interruptions and extensive contact with students, staff, parents, and the public; AND
- Indoor and outdoor environment.

**PHYSICAL DEMANDS:**

- Bending at the waist, kneeling or crouching, and reaching to retrieve and maintain files and records;
- Reaching overhead, above the shoulders and horizontally;
- Dexterity of hands and fingers to operate standard office equipment, computer keyboard, and other equipment necessary to complete the required duties;
- Hearing and speaking to exchange information in person and on the telephone;
- Visual ability to read, and to prepare/process documents and to monitor various services and personnel;
- Sitting for extended periods;
- Standing for extended periods;

- Walking over rough or uneven surfaces;
- Climbing, occasional use of stepladders; AND
- Physical activity may be required, which could include moderate lifting.

**HAZARDS:**

- Extended viewing of computer monitor; AND
- Working around and with office equipment having moving parts.

---

I have read the above position description and fully understand the requirements set forth therein. I hereby accept the position of Assistant Superintendent, Curriculum, Instruction, Innovation, and Support and agree to abide by the requirements and duties set forth. I will perform all duties and responsibilities to the best of my ability.

---

(Signature of Employee)

---

(Date)

In compliance with the Americans with Disabilities Act, the Chino Valley Unified School District will provide reasonable accommodations to qualified individuals with disabilities, and encourages both prospective and current employees to discuss potential accommodations with the Division of Human Resources.

Board Approved: June 29, 2009  
Revised: March 4, 2010  
Revised: October 20, 2016  
REVISED:

**CHINO VALLEY UNIFIED SCHOOL DISTRICT**  
**Position Description**

---

<b>TITLE:</b>	Assistant Superintendent, Facilities, Planning & Operations	<b>REPORTS:</b>	Superintendent
<b>DEPARTMENT:</b>	Facilities, Planning & Operations	<b>CLASSIFICATION:</b>	Management
<b>FLSA:</b>	Exempt	<b>WORK YEAR:</b>	226
<b>ISSUED:</b>	May 18, 2000	<b>SALARY:</b>	Range 12

---

**BASIC FUNCTION:**

Under the direction of the Superintendent AND ASSOCIATE SUPERINTENDENT OF BUSINESS SERVICES, plans, organizes, manages, and directs all aspects of the District's facilities, planning, and operations, providing leadership to District personnel, with specific responsibility for the planning, development, implementation, assessment, and improvement of facilities, planning, and operations in the District, and complying with federal and state laws, and District regulations, policies, and procedures.

**REPRESENTATIVE DUTIES:**

Incumbent may perform any combination of the essential functions shown below. This position description is not intended to be an exhaustive list of all duties, knowledge, or abilities, associated with this classification but is intended to accurately reflect the principle job elements.

**E = ESSENTIAL FUNCTIONS**

Provides leadership and direction in the identification and interpretation of needs and the establishment of priorities related to facilities, planning, and operations (facilities, planning, maintenance, operations and construction, transportation, and purchasing and warehouse); initiates and assists in coordinating the planning, development and implementation of programs and activities designed to meet such needs and priorities. **(E)**

Plans, organizes, and directs facilities, planning, and operations design and programs, delivery systems, strategies and techniques for achieving optimal educational results. **(E)**

Coordinates those staff development programs with District and school site staff which relate to the implementation of facilities, planning, and operations priorities. **(E)**

Works collaboratively with the District's management team and other administrators to ensure the coordination, alignment, and articulation of a comprehensive educational services/instructional program pre-K-12 that meets the needs of the diverse student population of the District. **(E)**

**WORKS COLLABORATIVELY WITH THE ASSOCIATE SUPERINTENDENT OF BUSINESS SERVICES IN PLANNING, DEVELOPING, AND IMPLEMENTING THE DISTRICT'S BOND PROGRAM. (E)**

Develops, coordinates, and integrates the long- and short-range planning operations of the District in conjunction with all affected local, county, and state agencies (including private development), to accommodate District growth in an efficient and effective manner. (E)

Prepares and coordinates the District Facilities Master Plan. (E)

Makes recommendations regarding facility utilization and new site acquisition, and acts as a liaison between the District and community groups affected by new school construction. (E)

Works closely with architects to ensure cost effective construction. (E)

Acts as District liaison with local, county and state agencies involved in the building program; serves as the District's representative in obtaining funds for new construction. (E)

Actively manages the District building deferred maintenance program. (E)

Manages financial effectiveness of the District's facilities and planning organization. (E)

Prepares District-imposed fee projection budgets, and plans for growth accommodation projects. (E)

Maintains all documentation reflecting fees collected and agreements entered into by the District.

Assists all departments as requested in providing student growth projections, and developing and recommending changes in the District's attendance areas.

Prepares and maintains District facilities and building plans.

Prepares and presents necessary reports/studies on matters pertaining to the impact of growth to the administration, Board of Education, and other local, state, or federal boards, commissions, councils, and other interested community or commercial organizations. (E)

Maintains accurate knowledge of legislation related to school facilities and growth accommodation and assures that the Board of Education is kept aware of such matters.

Integrates the services of District architects, legal counsel, technical and financial consultants, agency building inspectors and contractor representatives as they affect District planning and facility development operations. (E)

Coordinates with legal counsel and be responsible for ensuring the proper legal documentation of developer agreements, mitigation agreements, and memorandums of understanding. (E)

Develops, implements, and manages the District's energy conservation program. (E)

Establishes a climate within the Division of Facilities, Planning & Operations that is conducive to appropriate conduct, performance, attitude, job satisfaction, and service orientation. (E)

Maintains an updated, current working knowledge of and provides the management team with assistance in the interpretation and application of statues and regulations which deal with the assigned areas of responsibility. (E)

Develops, evaluates, and makes recommendations to the Superintendent, regarding District policies as they pertain to the assigned areas of responsibility, and provides interpretation of District policies and procedures, ensuring compliance with all federal and state laws, regulations and policies. **(E)**

Follows a planned professional growth program, participates actively in local, state, and national professional associations/organizations; and studies local, state, and national guidelines for effective services.

Directs the development and approves the departmental budget for assigned areas of responsibility. **(E)**

Functions as a member of the District's management team, coordinates with other management personnel in the areas of assigned responsibility. **(E)**

Supervises and evaluates the performance of assigned staff, interviews and selects employees, and recommends transfers, reassignments, terminations, and disciplinary actions; plans, coordinates, and arranges for appropriate training of subordinates. **(E)**

Directs the preparation and maintenance of a variety of narrative and statistical reports (including state and federal reports as required), records, and files; prepares agendas and memos; and, maintains all documentation reflecting agreements entered into. **(E)**

Develops and implements long- and short-term plans and activities to ensure compliance with the District policies, education code, and state and federal regulations and laws in an efficient and effective manner. **(E)**

Assures accurate and timely dissemination of information. **(E)**

Serves on committees such as the District's management team and other committees as appropriate or assigned by immediate supervisor. **(E)**

Represents the District as a liaison in meeting with county/state/federal agencies, institutions, and committees that are related to areas of responsibility as assigned.

Represents the District, when so assigned in social, organizational, ceremonial, political, or other functions.

Keeps informed of current trends in theory and practices of assigned areas of responsibility, and other pertinent areas, such as federal, state and local laws and District regulations, policies, and procedures, and assures that administration is kept aware of such matters. **(E)**

Provides leadership and expertise in forming, guiding, and counseling District committees, groups, councils, and advisories for assigned areas of responsibility, providing leadership, support, and guidance to staff and members of the community to ensure thorough communication relative to the educational design and delivery process. Also ensures that community advisory groups have the opportunity to participate in the processes of assessment and evaluation of the Division of Facilities, Planning & Operations. **(E)**

Attends all Board of Education meetings. **(E)**

Perform all other related duties as may be assigned.



## **MINIMUM REQUIREMENTS:**

### **EDUCATION AND EXPERIENCE:**

Bachelor's degree is required. Master's degree in management, planning, urban planning, construction management, or a related field is required. Doctoral degree in related field is preferred.

Completion of courses in school facilities, planning, and operations is desirable. A minimum of five (5) years of management experience in planning, construction, maintenance, business and/or other job related occupation is required. Experience working directly with public school districts is desirable. Demonstrated experience in the areas of urban planning, facility planning/development/construction, maintenance, transportation, purchasing and warehouse is desirable.

### **KNOWLEDGE AND ABILITIES:**

#### **KNOWLEDGE OF:**

- Statistics and their use in future planning based on demographic data;
- Public agencies responsible for the planning and development of the local area;
- Relationship between federal, state, county, and city legislative boards, commissions, and councils as well as their respective planning objectives and programs;
- Legal and business management concepts necessary to enable the proper functioning of District staff, technical, and legal consultants and the various government and area building industry representatives;
- Philosophical, educational, fiscal, and legal aspects affecting facilities, planning, and operations;
- Governmental budgeting, accounting, purchasing, stores, insurance, and contracts.
- Research methods and report writing techniques;
- Audit and fiscal control procedures;
- District's educational and instructional objectives;
- District organization, operations, policies, and procedures;
- Technical aspects of field of specialty;
- Principles of organization, operation, and supervision;
- Principles, practices, trends, goals, and objectives of public education and assigned areas of responsibility;
- Modern technology and office procedures and methods, computer equipment, and computer software necessary to perform required duties;
- Budget preparation and control;
- Applicable federal, state, and local laws, codes, regulations, policies, and procedures related to assigned activities; AND
- Oral and written communication skills, including English usage, grammar, spelling, punctuation, vocabulary, composition, and mathematics.

#### **ABILITY TO:**

- Plan, organize, and administer a comprehensive facilities, planning, and operations program;
- Administer assigned budgets and allocate funds;
- Demonstrate leadership qualities and utilize motivational techniques and strategies in the development of an operational mode that is cost effective;
- Operate a computer terminal and audio-visual equipment;

- Operate computer applications for complex financial management and position control management;
- Communicate effectively, both orally and in writing;
- Write in a clear and concise manner for broad public appeal and interpretation.
- Gain cooperation through discussion and persuasion;
- Coordinate and supervise the work of others;
- Analyze situations carefully and adopt an effective course of action;
- Interpret, apply, and explain administrative and board policies, laws, regulations, and collective bargaining agreements that pertain to assigned areas of responsibility;
- Plan, organize, and prioritize work to meet multiple schedules and deadlines, and manage simultaneous tasks, with many interruptions;
- Work independently with minimum direction and supervision; work under pressure;
- Understand, analyze, and prepare comprehensive, narrative and statistical reports;
- Establish and maintain cooperative and effective working relationships with district personnel, community members, and external companies and agencies in the course of performing assigned duties; AND
- Supervise and evaluate the performance of assigned staff.

**WORKING CONDITIONS:**

**ENVIRONMENT:**

- District office environment and school sites;
- Occasional work site visitations;
- Extensive contact with representatives of the building industry;
- Demanding timelines;
- Subject to driving to a variety of locations to conduct work during day and evening hours;
- Subject to frequent interruptions and extensive contact with students, staff, parents, and the public; AND
- Indoor and outdoor environment.

**PHYSICAL DEMANDS:**

- Bending at the waist, kneeling or crouching, and reaching to retrieve and maintain files and records;
- Reaching overhead, above the shoulders and horizontally;
- Dexterity of hands and fingers to operate standard office equipment, computer keyboard, and other equipment necessary to complete the required duties;
- Hearing and speaking to exchange information in person and on the telephone;
- Visual ability to read, and to prepare/process documents and to monitor various services and personnel;
- Sitting for extended periods;
- Standing for extended periods;
- Walking over rough or uneven surfaces;
- Climbing, occasional use of stepladders; AND
- Physical activity may be required, which could include moderate lifting.

**HAZARDS:**

- Some contact with toxic materials;
- Some work at sites where hardhats are required;
- Exposure to dirt and other materials around a work site;
- Occasional work around large pieces of equipment having moving parts;
- Extended viewing of computer monitor; AND
- Working around and with office equipment having moving parts.

---

I have read the above position description and fully understand the requirements set forth therein. I hereby accept the position of Assistant Superintendent, Facilities, Planning & Operations and agree to abide by the requirements and duties set forth. I will perform all duties and responsibilities to the best of my ability.

---

(Signature of Employee)

---

(Date)

In compliance with the Americans with Disabilities Act, the Chino Valley Unified School District will provide reasonable accommodations to qualified individuals with disabilities, and encourages both prospective and current employees to discuss potential accommodations with the Division of Human Resources.

Board Approved:        May 18, 2000  
Revised:                September 21, 2000  
Revised:                March 4, 2010  
REVISED:

**CHINO VALLEY UNIFIED SCHOOL DISTRICT**  
**Position Description**

---

<b>TITLE:</b>	Associate Superintendent, Educational Services CURRICULUM, INSTRUCTION, INNOVATION, AND SUPPORT	<b>REPORTS:</b>	Superintendent
<b>DEPARTMENT:</b>	Educational Services CURRICULUM, INSTRUCTION, INNOVATION, AND SUPPORT	<b>CLASSIFICATION:</b>	Management
<b>FLSA:</b>	Exempt	<b>WORK YEAR:</b>	226
<b>ISSUED:</b>	07/01/2004	<b>SALARY:</b>	Range 9

---

**BASIC FUNCTION:**

~~Responsible for the management and leadership of the District's curriculum, instructional programs, and support services as assigned by the Superintendent. Serves as the chief academic officer of the District.~~ UNDER THE DIRECTION OF THE SUPERINTENDENT, LEADS THE DEVELOPMENT OF THE INSTRUCTIONAL AND EDUCATIONAL PROGRAMS INCLUDING DIRECTING ALL ASPECTS OF CURRICULUM, INSTRUCTION, INNOVATION, AND SUPPORT (ALTERNATIVE EDUCATION, ASSESSMENT AND INSTRUCTIONAL TECHNOLOGY, ELEMENTARY AND SECONDARY CURRICULUM AND INSTRUCTION, HEALTH SERVICES/CHILD DEVELOPMENT, PROFESSIONAL DEVELOPMENT, SPECIAL EDUCATION, STUDENT SUPPORT SERVICES, AND TECHNOLOGY), PROVIDING LEADERSHIP TO DISTRICT PERSONNEL, K-12 PRINCIPALS, AND OTHER PERSONNEL ASSIGNED BY THE SUPERINTENDENT.

**REPRESENTATIVE DUTIES:**

INCUMBENT MAY PERFORM ANY COMBINATION OF THE ESSENTIAL FUNCTIONS SHOWN BELOW. THIS POSITION DESCRIPTION IS NOT INTENDED TO BE AN EXHAUSTIVE LIST OF ALL DUTIES, KNOWLEDGE, OR ABILITIES, ASSOCIATED WITH THIS CLASSIFICATION BUT IS INTENDED TO ACCURATELY REFLECT THE PRINCIPLE JOB ELEMENTS.

E = Essential Functions

~~Develops, implements, and evaluates the goals and objectives of the District as they pertain to the educational and instructional needs of the students.~~

~~Provides leadership and coordinates all schools and departments in the development, revision, implementation and assessment of the district's pre-kindergarten, child care, elementary and secondary instructional programs.~~

~~Maintains an updated, current working knowledge of laws, regulations, district policies, and goals relating to curriculum and instruction.~~

~~Assists in the development and formulation of District policy, goals and objectives as related to curriculum and instruction.~~

~~Serves as a member of the superintendent's cabinet and on other committees.~~

~~Represents the District in meetings and conferences pertaining to the instructional programs and curriculum.~~

~~Develops educational programs to meet District needs for all students.~~

~~Supervises District directors and coordinators in student support services, curriculum and instructional programs, national, state, and district assessments, state and federal projects, educational technology, special education, media services, child welfare and attendance, and health services.~~

~~Assists in the development and formulation of District policies and regulations.~~

~~Supervises and evaluates performance of principals as assigned by the superintendent.~~

~~Represents the District as a liaison in meetings with county/state/federal agencies, institutions and committees, which are related to curriculum and instruction.~~

~~Provides leadership and expertise in forming, guiding, and counseling District committees, groups, councils, and advisories for curriculum and instruction.~~

ASSISTS THE SUPERINTENDENT IN CHARTING THE OVERALL DISTRICT GOALS AND PRIORITIES, SUPPORTING THE WIDER CENTRAL OFFICE LEADERSHIP TEAM AND REPRESENTING THE DISTRICT AS THE LEADER OF CURRICULUM AND INSTRUCTION/TEACHING AND LEARNING AND EDUCATIONAL SERVICES. (E)

COORDINATES THOSE STAFF DEVELOPMENT PROGRAMS WITH DISTRICT AND SCHOOL-SITE STAFF WHICH RELATE TO THE IMPLEMENTATION OF CURRICULUM AND INSTRUCTION/TEACHING AND LEARNING AND EDUCATIONAL SERVICES PRIORITIES. (E)

ANALYZES PERFORMANCE TEST RESULTS FOR STUDENTS; ANALYZES CORRESPONDING DISTRICT CURRICULUM AND INSTRUCTION/TEACHING AND LEARNING AND EDUCATIONAL SERVICES FOR EFFECTIVENESS IN IMPROVING STUDENTS' ACHIEVEMENT. (E)

ESTABLISHES A CLIMATE WITHIN THE DIVISION OF CURRICULUM, INSTRUCTION, INNOVATION, AND SUPPORT THAT IS CONDUCTIVE TO APPROPRIATE CONDUCT, PERFORMANCE, ATTITUDE, JOB SATISFACTION, AND SERVICE ORIENTATION. (E)

MAINTAINS AN UPDATED, CURRENT WORKING KNOWLEDGE OF AND PROVIDES THE MANAGEMENT TEAM WITH ASSISTANCE IN THE INTERPRETATION AND APPLICATION OF STATUES AND REGULATIONS WHICH DEAL WITHIN THE DIVISION OF CURRICULUM, INSTRUCTION, INNOVATION, AND SUPPORT. (E)

DEVELOPS, EVALUATES, AND MAKES RECOMMENDATIONS TO THE SUPERINTENDENT, REGARDING DISTRICT POLICIES AS THEY PERTAIN TO THE NEEDS OF THE DIVISION OF CURRICULUM, INSTRUCTION, INNOVATION, AND SUPPORT, AND PROVIDES

INTERPRETATION OF DISTRICT POLICIES AND PROCEDURES, ENSURING COMPLIANCE WITH ALL FEDERAL AND STATE LAWS, REGULATIONS AND POLICIES. (E)

FOLLOWS A PLANNED PROFESSIONAL GROWTH PROGRAM, PARTICIPATES ACTIVELY IN LOCAL, STATE, AND NATIONAL PROFESSIONAL ASSOCIATIONS/ORGANIZATIONS; AND STUDIES LOCAL, STATE, AND NATIONAL GUIDELINES FOR EFFECTIVE SERVICES.

DIRECTS THE DEVELOPMENT AND APPROVES THE DEPARTMENTAL BUDGET FOR ASSIGNED AREAS OF RESPONSIBILITY. (E)

FUNCTIONS AS A MEMBER OF THE DISTRICT'S MANAGEMENT TEAM, COORDINATES WITH OTHER MANAGEMENT PERSONNEL IN THE AREAS OF ASSIGNED RESPONSIBILITY. (E)

SUPERVISES AND EVALUATES THE PERFORMANCE OF ASSIGNED STAFF, INTERVIEWS AND SELECTS EMPLOYEES, AND RECOMMENDS TRANSFERS, REASSIGNMENTS, TERMINATIONS, AND DISCIPLINARY ACTIONS; PLANS, COORDINATES, AND ARRANGES FOR APPROPRIATE TRAINING OF SUBORDINATES. (E)

DIRECTS THE PREPARATION AND MAINTENANCE OF A VARIETY OF NARRATIVE AND STATISTICAL REPORTS (INCLUDING STATE AND FEDERAL REPORTS AS REQUIRED), RECORDS, AND FILES; PREPARES AGENDAS AND MEMOS; AND, MAINTAINS ALL DOCUMENTATION REFLECTING AGREEMENTS ENTERED INTO. (E)

DEVELOPS AND IMPLEMENTS LONG- AND SHORT-TERM PLANS AND ACTIVITIES TO ENSURE COMPLIANCE WITH THE DISTRICT POLICIES, EDUCATION CODE, AND STATE AND FEDERAL REGULATIONS AND LAWS IN AN EFFICIENT AND EFFECTIVE MANNER. (E)

ASSURES ACCURATE AND TIMELY DISSEMINATION OF INFORMATION. (E)

SERVES ON COMMITTEES SUCH AS THE DISTRICT'S MANAGEMENT TEAM AND OTHER COMMITTEES AS APPROPRIATE OR ASSIGNED BY IMMEDIATE SUPERVISOR. (E)

REPRESENTS THE DISTRICT AS A LIAISON IN MEETING WITH COUNTY/STATE/FEDERAL AGENCIES, INSTITUTIONS, AND COMMITTEES THAT ARE RELATED TO AREAS OF RESPONSIBILITY AS ASSIGNED.

REPRESENTS THE DISTRICT, WHEN SO ASSIGNED IN SOCIAL, ORGANIZATIONAL, CEREMONIAL, POLITICAL, OR OTHER FUNCTIONS.

KEEPS INFORMED OF CURRENT TRENDS IN THEORY AND PRACTICES OF ASSIGNED AREAS OF RESPONSIBILITY, AND OTHER PERTINENT AREAS, SUCH AS FEDERAL, STATE AND LOCAL LAWS AND DISTRICT REGULATIONS, POLICIES, AND PROCEDURES, AND ASSURES THAT ADMINISTRATION IS KEPT AWARE OF SUCH MATTERS. (E)

PROVIDES LEADERSHIP AND EXPERTISE IN FORMING, GUIDING, AND COUNSELING DISTRICT COMMITTEES, GROUPS, COUNCILS, AND ADVISORIES FOR ASSIGNED AREAS OF RESPONSIBILITY, PROVIDING LEADERSHIP, SUPPORT, AND GUIDANCE TO STAFF AND MEMBERS OF THE COMMUNITY TO ENSURE THOROUGH COMMUNICATION RELATIVE TO THE EDUCATIONAL DESIGN AND DELIVERY PROCESS.

ATTENDS ALL BOARD OF EDUCATION MEETINGS. (E)

PERFORMS ALL OTHER DUTIES AS ASSIGNED.

**MINIMUM REQUIREMENTS:**

**EDUCATION, EXPERIENCE, LICENSES, AND OTHER REQUIREMENTS:**

BACHELOR'S DEGREE IS REQUIRED. Master's degree ~~or higher~~ in educational administration, CURRICULUM AND INSTRUCTION, OR RELATED FIELD IS ~~desirable~~ REQUIRED. DOCTORAL DEGREE IN RELATED FIELD IS PREFERRED.

COMPLETION OF COURSES IN CURRICULUM DEVELOPMENT AND COURSEWORK DESIGN, WITHIN THE ASSIGNED AREAS OF RESPONSIBILITY IS DESIRABLE. A MINIMUM OF FIVE (5) YEARS EXPERIENCE IN CURRICULUM AND DEVELOPMENT AND/OR OTHER JOB RELATED OCCUPATIONS IS REQUIRED. CENTRAL OFFICE EXPERIENCE IN CURRICULUM AND INSTRUCTION OR IN A RELATED FIELD AND EXPERIENCE WORKING DIRECTLY WITH PUBLIC SCHOOL DISTRICTS IS REQUIRED. ~~Five years of successful teaching experience at the elementary or secondary level and completion of educational administrative training program. Four years of experience in a responsible administrative position performing instructional support services related to function in a unified school district.~~

~~Hold~~ POSSESSION OF a valid California ~~administrative credential K-12~~ PRELIMINARY OR PROFESSIONAL CLEAR MULTIPLE OR SINGLE SUBJECT TEACHING CREDENTIAL AUTHORIZING SERVICE AS AN ELEMENTARY OR SECONDARY TEACHER IS REQUIRED.

POSSESSION OF A VALID CALIFORNIA ADMINISTRATIVE CREDENTIAL AUTHORIZING SERVICE AS AN ADMINISTRATOR IS REQUIRED.

EMPLOYMENT ELIGIBILITY THAT MAY INCLUDE FINGERPRINTS, HEALTH (TB), AND/OR OTHER EMPLOYMENT CLEARANCE.

MUST HAVE VALID CALIFORNIA DRIVER'S LICENSE AND AUTOMOBILE AVAILABLE FOR USE. MUST BE WILLING TO ATTEND EVENING, NIGHT, AND WEEKEND MEETINGS.

**KNOWLEDGE AND ABILITIES:**

**KNOWLEDGE OF:**

- CURRICULUM DEVELOPMENT, EVALUATION, AND IMPLEMENTATION OF INSTRUCTIONAL MATERIALS, AND MEASUREMENT AND EVALUATION STRATEGIES;
- DISTRICT'S EDUCATIONAL AND INSTRUCTIONAL OBJECTIVES AT ALL GRADE LEVELS;
- DISTRICT ORGANIZATION, OPERATIONS, POLICIES, AND PROCEDURES;
- TECHNICAL ASPECTS OF FIELD OF SPECIALTY;
- PRINCIPLES OF ORGANIZATION, OPERATION, AND SUPERVISION;
- PRINCIPLES, PRACTICES, TRENDS, GOALS, AND OBJECTIVES OF PUBLIC EDUCATION AND ASSIGNED AREAS OF RESPONSIBILITY;

- MODERN TECHNOLOGY AND OFFICE PROCEDURES AND METHODS, COMPUTER EQUIPMENT, AND COMPUTER SOFTWARE NECESSARY TO PERFORM REQUIRED DUTIES;
- BUDGET PREPARATION AND CONTROL;
- APPLICABLE FEDERAL, STATE, AND LOCAL LAWS, CODES, REGULATIONS, POLICIES, AND PROCEDURES RELATED TO ASSIGNED ACTIVITIES; AND
- ORAL AND WRITTEN COMMUNICATION SKILLS, INCLUDING ENGLISH USAGE, GRAMMAR, SPELLING, PUNCTUATION, VOCABULARY, COMPOSITION, AND MATHEMATICS.

**ABILITY TO:**

- PLAN, ORGANIZE, AND ADMINISTER A COMPREHENSIVE EDUCATIONAL SERVICES PROGRAM;
- ADMINISTER ASSIGNED BUDGETS AND ALLOCATE FUNDS;
- DEMONSTRATE LEADERSHIP QUALITIES AND UTILIZE MOTIVATIONAL TECHNIQUES AND STRATEGIES IN THE DEVELOPMENT OF AN OPERATIONAL MODE THAT IS COST EFFECTIVE;
- OPERATE A COMPUTER TERMINAL AND AUDIO-VISUAL EQUIPMENT;
- COMMUNICATE EFFECTIVELY, BOTH ORALLY AND IN WRITING;
- WRITE IN A CLEAR AND CONCISE MANNER FOR BROAD PUBLIC APPEAL AND INTERPRETATION;
- GAIN COOPERATION THROUGH DISCUSSION AND PERSUASION;
- COORDINATE AND SUPERVISE THE WORK OF OTHERS;
- ANALYZE SITUATIONS CAREFULLY AND ADOPT AN EFFECTIVE COURSE OF ACTION;
- INTERPRET, APPLY, AND EXPLAIN ADMINISTRATIVE AND BOARD POLICIES, LAWS, REGULATIONS, AND COLLECTIVE BARGAINING AGREEMENTS THAT PERTAIN TO AREAS OF RESPONSIBILITY;
- PLAN, ORGANIZE, AND PRIORITIZE WORK TO MEET MULTIPLE SCHEDULES AND DEADLINES, AND MANAGE SIMULTANEOUS TASKS, WITH MANY INTERRUPTIONS;
- WORK INDEPENDENTLY WITH MINIMUM DIRECTION AND SUPERVISION; WORK UNDER PRESSURE;
- UNDERSTAND, ANALYZE, AND PREPARE COMPREHENSIVE, NARRATIVE AND STATISTICAL REPORTS;
- ESTABLISH AND MAINTAIN COOPERATIVE AND EFFECTIVE WORKING RELATIONSHIPS WITH DISTRICT PERSONNEL, COMMUNITY MEMBERS, AND EXTERNAL COMPANIES AND AGENCIES IN THE COURSE OF PERFORMING ASSIGNED DUTIES; AND
- SUPERVISE AND EVALUATE THE PERFORMANCE OF ASSIGNED STAFF.

**WORKING CONDITIONS:**

**ENVIRONMENT:**

- DISTRICT OFFICE ENVIRONMENT AND SCHOOL SITES;
- DEMANDING TIMELINES;
- SUBJECT TO DRIVING TO A VARIETY OF LOCATIONS TO CONDUCT WORK DURING DAY AND EVENING HOURS;



- SUBJECT TO FREQUENT INTERRUPTIONS AND EXTENSIVE CONTACT WITH STUDENTS, STAFF, PARENTS, AND THE PUBLIC; AND
- INDOOR AND OUTDOOR ENVIRONMENT.

**PHYSICAL DEMANDS:**

- BENDING AT THE WAIST, KNEELING OR CROUCHING, AND REACHING TO RETRIEVE AND MAINTAIN FILES AND RECORDS;
- REACHING OVERHEAD, ABOVE THE SHOULDERS AND HORIZONTALLY;
- DEXTERITY OF HANDS AND FINGERS TO OPERATE STANDARD OFFICE EQUIPMENT, COMPUTER KEYBOARD, AND OTHER EQUIPMENT NECESSARY TO COMPLETE THE REQUIRED DUTIES;
- HEARING AND SPEAKING TO EXCHANGE INFORMATION IN PERSON AND ON THE TELEPHONE;
- VISUAL ABILITY TO READ, AND TO PREPARE/PROCESS DOCUMENTS AND TO MONITOR VARIOUS SERVICES AND PERSONNEL;
- SITTING FOR EXTENDED PERIODS;
- STANDING FOR EXTENDED PERIODS;
- WALKING OVER ROUGH OR UNEVEN SURFACES;
- CLIMBING, OCCASIONAL USE OF STEPLADDERS; AND
- PHYSICAL ACTIVITY MAY BE REQUIRED, WHICH COULD INCLUDE MODERATE LIFTING.

**HAZARDS:**

- EXTENDED VIEWING OF COMPUTER MONITOR; AND
- WORKING AROUND AND WITH OFFICE EQUIPMENT HAVING MOVING PARTS.

---

I HAVE READ THE ABOVE POSITION DESCRIPTION AND FULLY UNDERSTAND THE REQUIREMENTS SET FORTH THEREIN. I HEREBY ACCEPT THE POSITION OF ASSOCIATE SUPERINTENDENT, CURRICULUM, INSTRUCTION, INNOVATION, AND SUPPORT AND AGREE TO ABIDE BY THE REQUIREMENTS AND DUTIES SET FORTH. I WILL PERFORM ALL DUTIES AND RESPONSIBILITIES TO THE BEST OF MY ABILITY.

---

(SIGNATURE OF EMPLOYEE)

---

(DATE)

IN COMPLIANCE WITH THE AMERICANS WITH DISABILITIES ACT, THE CHINO VALLEY UNIFIED SCHOOL DISTRICT WILL PROVIDE REASONABLE ACCOMMODATIONS TO QUALIFIED INDIVIDUALS WITH DISABILITIES, AND ENCOURAGES BOTH PROSPECTIVE AND CURRENT EMPLOYEES TO DISCUSS POTENTIAL ACCOMMODATIONS WITH THE DIVISION OF HUMAN RESOURCES.

Board Approved: July 1, 2004  
 REVISED:

**CHINO VALLEY UNIFIED SCHOOL DISTRICT**

**Our Motto:**

Student Achievement • Safe Schools • Positive School Climate  
Humility • Civility • Service

**DATE:** June 28, 2018

**TO:** Members, Board of Education

**FROM:** Wayne M. Joseph, Superintendent

**PREPARED BY:** Sandra H. Chen, Assistant Superintendent, Business Services  
Liz Pensick, Director, Fiscal Services

**SUBJECT: REVISION OF BOARD POLICY AND ADMINISTRATIVE  
REGULATION 3100 BUSINESS AND NONINSTRUCTIONAL  
OPERATIONS – BUDGET**

=====

**BACKGROUND**

Board policies and regulations are routinely developed as a result of changes in law, mandates, federal regulations, and current practice. Board Policy and Administrative Regulation 3100 Business and Noninstructional Operations – Budget are being revised to reflect updates to both laws and current practice.

New language is provided in UPPER CASE while old language to be deleted is ~~lined through~~.

Consideration of this item supports the goals identified within the District’s Strategic Plan.

**RECOMMENDATION**

It is recommended the Board of Education receive for information the revision of Board Policy and Administrative Regulation 3100 Business and Noninstructional Operations – Budget.

**FISCAL IMPACT**

None.

WMJ:SHC:LP:wc

**BUDGET**

The Board of Education ~~accepts~~ RECOGNIZES ITS CRITICAL responsibility for adopting a sound budget for each fiscal year that is compatible with the District's vision, ~~and~~ goals, PRIORITIES, LOCAL CONTROL AND ACCOUNTABILITY PLAN (LCAP), AND OTHER COMPREHENSIVE PLANS. The District budget shall guide administrative decisions and actions throughout the year and shall serve as a tool for monitoring the fiscal health of the District. ~~The Board shall establish and maintain a general fund reserve for economic uncertainty that meets or exceeds the requirements of law.~~

(cf. 0000 – Vision)  
(cf. 0200 – Goals for the School District)  
(cf. 0400 – Comprehensive Plans)  
(cf. 0460 – Local Control and Accountability Plan)  
(cf. 3300 – Expenditures/Expending Authority)  
(cf. 3460 – Financial Reports and Accountability)  
(cf. 9000 – Role of the Board)

The District budget shall show a complete plan and itemized statement of all proposed expenditures and all estimated revenues for the following fiscal year, together with a comparison of revenues and expenditures for the current fiscal year. The budget shall also include the appropriations limit and the total annual appropriations subject to limitation as determined pursuant to Government Code 7900-7914. (Education Code 42122)

**Budget Development and Adoption Process**

IN ORDER TO PROVIDE GUIDANCE IN THE DEVELOPMENT OF THE BUDGET, THE BOARD SHALL ANNUALLY ESTABLISH BUDGET PRIORTIES BASED ON IDENTIFIED DISTRICT NEEDS AND GOALS AND ON REALISTIC PROJECTIONS OF AVAILABLE FUNDS.

The Superintendent or designee shall ~~determine the manner in which the budget is developed and shall schedule the budget adoption process in accordance with the single budget adoption process described in Education Code 42127(i). He/she shall annually notify the county superintendent of schools of the district's decision to use the single budget adoption process in the subsequent year~~ OVERSEE THE PREPARATION OF A PROPOSED DISTRICT BUDGET FOR APPROVAL BY THE BOARD AND SHALL INVOLVE APPROPRIATE STAFF IN THE DEVELOPMENT OF BUDGET PROJECTIONS.

The Board ~~encourages public input in the budget development process and shall hold A public hearings ON THE PROPOSED BUDGET and meetings~~ in accordance with Education Code 42103 and 42127.

**BUDGET (cont.)**

(cf. 9320 – Meetings and Notices)  
(cf. 9322 – Agenda/Meeting Materials)  
(cf. 9323 – Meeting Conduct)

THE BOARD SHALL ADOPT THE DISTRICT BUDGET ON OR BEFORE JULY 1 OF EACH YEAR. (Education Code 42127)

AT A PUBLIC MEETING SCHEDULED ON A DATE AFTER THE PUBLIC HEARING ON THE BUDGET, THE BOARD SHALL, FOLLOWING ITS ADOPTION OF THE LCAP OR AN ANNUAL UPDATE TO THE LCAP, ADOPT THE BUDGET. THE BUDGET SHALL INCLUDE THE EXPENDITURES NECESSARY TO IMPLEMENT THE LCAP OR THE ANNUAL UPDATE TO THE LCAP. (Education Code 42127, 52062)

The budget that is formally adopted by the Board shall ~~be in the format~~ ADHERE TO THE STATE'S STANDARDIZED ACCOUNT CODE STRUCTURE prescribed by the Superintendent of Public Instruction. The Superintendent or designee may supplement this format with additional information as necessary to effectively communicate the budget to the board, staff, and public.

NO LATER THAN FIVE DAYS AFTER THE BOARD ADOPTS THE DISTRICT BUDGET OR BY JULY 1, WHICHEVER OCCURS FIRST, THE BOARD SHALL FILE WITH THE COUNTY SUPERINTENDENT OF SCHOOLS THE ADOPTED DISTRICT BUDGET AND SUPPORTING DATA. THE BUDGET AND SUPPORTING DATA SHALL BE MAINTAINED AND MADE AVAILABLE FOR PUBLIC REVIEW. (Education Code 42127)

IF THE COUNTY SUPERINTENDENT DISAPPROVES OR CONDITIONALLY APPROVES THE DISTRICT'S BUDGET, THE BOARD SHALL REVIEW AND RESPOND TO HIS/HER RECOMMENDATIONS AT A PUBLIC MEETING ON OR BEFORE OCTOBER 8. THE RESPONSE SHALL INCLUDE ANY REVISIONS TO THE ADOPTED BUDGET AND ANY OTHER PROPOSED ACTIONS TO BE TAKEN AS A RESULT OF THOSE RECOMMENDATIONS. (Education Code 42127)

**Budget Advisory Committee**

The Superintendent or designee may appoint a Budget Advisory Committee composed of staff, board representatives, and/or members of the community. The committee shall ~~develop~~ SUBMIT recommendations during the budget development process and its duties shall be assigned each year based on district needs. All recommendations of the committee shall be advisory only and shall not be binding on the Board, Superintendent or designee.

(cf. 1220 – Citizen Advisory Committees)  
(cf. 2230 – Representative and Deliberative Groups)  
(cf. 3350 – Travel Expenses)  
(cf. 9130 – Board Committees)  
(cf. 9140 – Board Representatives)

**BUDGET (cont.)**

~~In developing the District budget, the Superintendent or designee shall analyze criteria and standards adopted by the State Board of Education which address estimation of funded Average Daily Attendance (ADA), projected enrollment, ratio of ADA to enrollment, projected revenue limit, salaries and benefits, other revenues and expenditures, facilities maintenance, deficit spending, fund balance, and reserves. The budget review shall also identify supplemental information regarding contingent liabilities, use of one-time revenues for ongoing expenditures, use of ongoing revenues for one-time expenditures, contingent revenues, contributions, long-term commitments, unfunded liabilities, and the status of labor agreements. (Education Code 33127, 33128, 33129; CCR 15440-15451)~~

~~The Board may establish other budget assumptions or parameters which may take into consideration the stability of funding sources, legal requirements and constraints on the use of funds, anticipated increases and/or decreases in the cost of services and supplies, categorical program requirements, and any other factors necessary to ensure that the budget is a realistic plan for district revenues and expenditures.~~

**Budget Criteria and Standards**

~~In developing the district budget, †The Superintendent or designee shall analyze DEVELOP A DISTRICT BUDGET IN ACCORDANCE WITH STATE criteria and standards SPECIFIED IN 5 CCR 15440-15450 AS THEY RELATE TO PROJECTIONS OF adopted by the State Board of Education which address estimation of funded average daily attendance (ADA), projected enrollment, ratio of ADA to enrollment, LOCAL CONTROL FUNDING FORMULA REVENUE, projected revenue limit, salaries and benefits, other revenues and expenditures, facilities maintenance, deficit spending, UNRESTRICTED GENERAL fund balance, and reserves,. the budget review IN ADDITION, HE/SHE shall PROVIDE THE also identify supplemental information regarding SPECIFIED IN 5 CCR 15451 WHICH ADDRESSES THE METHODOLOGY AND BUDGET ASSUMPTIONS USED, contingent liabilities, use of one-time revenues for ongoing expenditures, use of ongoing revenues for one-time expenditures, contingent revenues, contributions, long-term commitments, unfunded liabilities, and the status of labor COLLECTIVE BARGAINING agreements, THE LCAP, AND LCAP EXPENDITURES. (Education Code 33128, 33128.3, 33129, 42127.01; 5 CCR 15440-15451)~~

~~THE DISTRICT BUDGET SHALL PROVIDE FOR INCREASING OR IMPROVING SERVICES FOR UNDUPLICATED STUDENTS AT LEAST IN PROPORTION TO THE INCREASE IN FUNDS APPORTIONED ON THE BASIS OF THE NUMBER AND CONCENTRATION OF UNDUPLICATED STUDENTS IN ACCORDANCE WITH 5 CCR 15496. UNDUPLICATED STUDENTS ARE STUDENTS WHO ARE ELIGIBLE FOR FREE OR REDUCED-PRICE MEALS, ENGLISH LEARNERS, AND/OR FOSTER YOUTH. (Education Code 42238.07; 5 CCR 15496).~~

(cf. 3553 - Free and Reduced Price Meals)

(cf. 6173.1 - Education for Foster Youth)

(cf. 6174 - Education for English Learners)

**BUDGET (cont.)**

~~The Board shall establish and maintain a general fund reserve for economic uncertainty that meets or exceeds the requirements of law. (Education Code 33128.3; 5 CCR 15450.)~~

The Board may establish other budget assumptions or parameters which may take into consideration the stability of funding sources, legal requirements and constraints on the use of funds, anticipated increases and/or decreases in the cost of services and supplies, ~~categorical~~ program requirements, and any other factors necessary to ensure that the budget is a realistic plan for district revenues and expenditures.

(cf. 2210 – Administrative Discretion Regarding Board Policy)

(cf. 3110 – Transfer of Funds)

**Fund Balance**

~~The fund balance policy is intended to provide guidelines during the preparation and execution of the annual budget to ensure that sufficient reserves are maintained for unanticipated expenditures or revenue shortfalls. It also is intended to preserve flexibility throughout the fiscal year to make adjustments in funding for programs approved in connection with the annual budget. The fund balance policy should be established based upon a long-term perspective recognizing that stated thresholds are considered minimum balances. The main objective of establishing and maintaining a fund balance policy is for the District to be in a strong fiscal position that will allow for better position to weather negative economic trends.~~

~~The District establishes and maintains classifications of SHALL CLASSIFY fund balanceS in accordance COMPLIANCE with Governmental Accounting and Financial Standards Board (GASB) Statement no. 54, fund balance reporting and governmental fund type definitions. The fund balance consists of five classifications: nonspendable, restricted, committed, assigned, and unassigned. AS FOLLOWS:~~

- ~~• 1. Nonspendable fund balance consists of funds~~ INCLUDES AMOUNTS that cannot be spent due to their ARE NOT EXPECTED TO BE CONVERTED TO CASH, SUCH AS RESOURCES THAT ARE NOT IN SPENDABLE form (e.g. Inventories and prepaids) or funds that ARE legally or contractually ~~must~~ REQUIRED TO be maintained intact.
- ~~• 2. Restricted fund balance consists of funds that are mandated for a~~ INCLUDES AMOUNTS CONSTRAINED TO specific purposeS by external parties, constitutional provisions or enabling legislation THEIR PROVIDERS OR BY LAW.
- ~~• 3. Committed fund balance consists of funds that are set aside for a~~ INCLUDES AMOUNTS CONSTRAINED TO specific purposeS by the District's highest level of decision making authority (governing board). Formal action must be taken prior to the end of the fiscal year. The same formal action must be taken to remove or change the limitations placed on the funds BOARD.

**BUDGET (cont.)**

- ~~4.~~ Assigned fund balance ~~consists of funds that are set aside with the intent to be used~~ INCLUDES AMOUNTS WHICH ARE INTENDED for a specific purpose BUT DO NOT MEET THE CRITERIA TO BE CLASSIFIED AS RESTRICTED OR COMMITTED. ~~by the District's highest level of decision making authority or a body or official that has been given~~ ~~†~~The BOARD DELEGATES or a body or official that has been given the authority to assign funds TO THE ASSIGNED FUND BALANCE TO THE SUPERINTENDENT AND AUTHORIZES THE ASSIGNMENT OF SUCH Assigned funds cannot cause a deficit in unassigned fund balance TO BE MADE ANY TIME PRIOR TO THE ISSUANCE OF THE FINANCIAL STATEMENTS. THE SUPERINTENDENT MAY FURTHER DELEGATE THE AUTHORITY TO ASSIGN FUNDS AT HIS/HER DISCRETION.
- ~~5.~~ Unassigned fund balance ~~consists of excess funds that have not been classified in the previous four classifications. All funds in this classification are considered spendable resources. This classification also provides the resources necessary to meet unexpected expenditures and revenue shortfalls~~ INCLUDES AMOUNTS THAT ARE AVAILABLE FOR ANY PURPOSE.

WHEN MULTIPLE TYPES OF FUNDS ARE AVAILABLE FOR AN EXPENDITURE, THE DISTRICT SHALL FIRST UTILIZE FUNDS FROM THE RESTRICTED FUND BALANCE AS APPROPRIATE, THEN FROM THE COMMITTED FUND BALANCE, THEN FROM THE ASSIGNED FUND BALANCE, AND LASTLY FROM THE UNASSIGNED FUND BALANCE.

THE BOARD INTENDS TO MAINTAIN A MINIMUM ASSIGNED AND UNASSIGNED FUND BALANCE IN AN AMOUNT THE BOARD DEEMS SUFFICIENT TO MAINTAIN FISCAL SOLVENCY AND STABILITY AND TO PROTECT THE DISTRICT AGAINST UNFORESEEN CIRCUMSTANCES.

IF THE ASSIGNED AND UNASSIGNED FUND BALANCE FALLS BELOW THE LEVEL SET BY THE BOARD DUE TO AN EMERGENCY SITUATION, UNEXPECTED EXPENDITURES, OR REVENUE SHORTFALLS, THE BOARD SHALL DEVELOP A PLAN TO RECOVER THE FUND BALANCE WHICH MAY INCLUDE DEDICATING NEW UNRESTRICTED REVENUES, REDUCING EXPENDITURES, AND/OR INCREASING REVENUES OR PURSUING OTHER FUNDING SOURCES.

**NONSPENDABLE AND RESTRICTED FUNDS**

~~It is the responsibility of the chief business official to report all nonspendable and restricted funds appropriately in the district's financial statements.~~

**FUND BALANCE SPENDING ORDER**

~~Unless legal requirements disallow it, the District will spend the most restricted dollars before less restricted in the following order:~~

**BUDGET (cont.)**

1. ~~Nonspendable — if the funds become spendable~~
2. ~~Restricted~~
3. ~~Committed~~
4. ~~Assigned~~
5. ~~Unassigned~~

**~~AUTHORITY TO COMMIT FUNDS~~**

~~The District's governing board has the authority to set aside funds for a specific purpose. Any funds set aside as committed fund balance requires the passage of a resolution by a simple majority vote. The passage of a resolution must take place prior to June 30th of the applicable fiscal year.~~

**~~AUTHORITY TO ASSIGN FUNDS~~**

~~Upon passage of the fund balance policy, authority is given to the District's chief business official to assign funds for specific purposes. Any funds set aside as assigned fund balance must be reported to the District's governing board at their next regular meeting. The governing board has the authority to remove or change the assignment of the funds with a simple majority vote.~~

~~The District's governing board has the authority to set aside funds for the intended use of a specific purpose. Any funds set aside as assigned fund balance requires a simple majority vote and must be recorded in the minutes.~~

**~~UNASSIGNED FUND BALANCE~~**

~~Unassigned fund balance is the residual amount of fund balance in the general fund. It represents the resources available for future spending. An appropriate level of unassigned fund balance should be maintained in the general fund in order to cover unexpected expenditures and revenue shortfalls.~~

~~Unassigned fund balance may be accessed in the event of unexpected expenditures up to the minimum established level upon approval of a budget revision by the District's governing board. In the event of projected revenue shortfalls, it is the responsibility of the chief business official to report the projections to the district's governing board on a quarterly basis and shall be recorded in the minutes.~~

~~Any budget revision that will result in the unassigned fund balance dropping below the minimum level will require the approval of 2/3 vote of the district's governing board.~~



**BUDGET (cont.)****MINIMUM FUND BALANCE**

~~The fund balance of the District's general fund is intended to contain reserves to provide stability and flexibility in response to unexpected adversity and/or opportunities. The target is to maintain an unrestricted fund balance of not less than three percent (3%) of combined general fund expenditures and other financing uses in the unassigned fund balance classification. The rationale for this level of reserves is to provide the following:~~

- ~~• To meet state required reserve levels in accordance with the standards and criteria adopted by the State Board of Education (education code 33128)~~
- ~~• To provide adequate cash to meet financial obligations~~
- ~~• To provide available funds to meet unanticipated or emergency financial obligations~~
- ~~• To provide stability during periods of economic distress~~

**RESERVE BALANCE**

THE DISTRICT BUDGET SHALL INCLUDE A MINIMUM RESERVE BALANCE FOR ECONOMIC UNCERTAINTIES THAT IS CONSISTENT WITH THE PERCENTAGE OR AMOUNT SPECIFIED IN 5 CCR 15450.

IN ANY YEAR THAT THE DISTRICT IS NOTIFIED BY THE SUPERINTENDENT OF PUBLIC INSTRUCTION THAT THE AMOUNT OF MONIES IN THE STATE PUBLIC SCHOOL SYSTEM STABILIZATION ACCOUNT EQUALS OR EXCEEDS THREE PERCENT OF THE COMBINED TOTAL OF GENERAL FUND REVENUES APPROPRIATED FOR SCHOOL DISTRICTS AND ALLOCATED LOCAL PROCEEDS OF TAXES, THE DISTRICT BUDGET SHALL NOT CONTAIN A COMBINED ASSIGNED OR UNASSIGNED ENDING GENERAL FUND BALANCE THAT IS IN EXCESS OF 10 PERCENT OF THESE FUNDS. (Education Code 41202, 42127.01)

**Long-Term Financial Obligations**

The District's current-year budget and multi-year projections shall include adequate provisions for addressing the District's long-term financial obligations, including, but not limited to, long-term obligations resulting from collective bargaining agreements, financing of facilities projects, unfunded or future liability for retiree benefits, and accrued workers' compensation claims.

(cf. 4141/4241 – Collective Bargaining Agreement)  
(cf. 4154/4254/4354 – Health and Welfare Benefits)

**BUDGET (cont.)**

(cf. 7210 – Facilities Financing)

(cf. 9250 – Remuneration, Reimbursement and Other Benefits)

~~Regardless of the funding strategy used by the District, Governmental Accounting Standards Board (GASB) statement 45 requires the District to report the annual expense of OPEBS and, to the extent that the OPEBS are not prefunded, to report them as a liability on the district's financial statements; see AR 3460 Financial Reports and Accountability.~~

The Board shall approve a plan for meeting the District's long term obligations to fund non-pension, Other Postemployment Benefits (OPEBS). This plan shall include a specific funding strategy and the method that will be used to finance the District's annual fiscal obligations for such benefits in a manner that continually reduces the deficit to the District to the extent possible. The Board reserves the authority to review and amend the funding strategy as necessary to ensure that it continues to serve the best interests of the District and maintains flexibility to adjust for changing budgetary considerations.

When the Superintendent or designee presents a report to the Board on the estimated accrued but unfunded cost of OPEBS, the Board shall disclose, as a separate agenda item at the same meeting, whether or not it will reserve a sufficient amount of money in its budget to fund the present value of the benefits of existing retirees and/or the future cost of employees who are eligible for benefits in the current fiscal year. (Education Code 42140)

When the Superintendent or designee presents a report to the Board on the estimated accrued but unfunded cost of workers' compensation claims, the Board shall disclose, as a separate agenda item at the same meeting, whether or not it will reserve in the budget sufficient amounts to fund the present value of accrued but unfunded workers' compensation claims or if it is otherwise decreasing the amount in its workers' compensation reserve fund. The Board shall annually certify to the County Superintendent the amount, if any, that it has decided to reserve in the budget for these costs. The Board shall submit to the County Superintendent any budget revisions that may be necessary to account for this budget reserve. (Education Code 42141)

**Budget Amendments**

NO LATER THAN 45 DAYS AFTER THE GOVERNOR SIGNS THE ANNUAL BUDGET ACT, THE SUPERINTENDENT OR DESIGNEE SHALL MAKE AVAILABLE FOR PUBLIC REVIEW ANY REVISIONS IN BUDGETED REVENUES AND EXPENDITURES WHICH OCCUR AS A RESULT OF THE FUNDING MADE AVAILABLE BY THAT BUDGET ACT. (Education Code 42127)

Whenever revenues and expenditures change significantly throughout the year, the Superintendent or designee shall recommend budget amendments to ensure accurate projections of the District's net ending balance. When final figures for the prior-year

**BUDGET (cont.)**

budget are available, this information shall be used as soon as possible to update the current-year budget's beginning balance and projected revenues and expenditures.

In addition, budget amendments shall be submitted for board approval when ~~the state budget is adopted~~, collective bargaining agreements are accepted, district income declines, increased revenues or unanticipated savings are made available to the District, program proposals are significantly different from those approved during budget adoption, interfund transfers are needed to meet actual program expenditures, and/or other significant changes occur that impact budget projections.

**Legal Reference:**EDUCATION CODE

1240 Duties of County Superintendent of Schools  
 33127–33131 Standards and criteria for local budgets and expenditures  
 41202 Determination of minimum level of education funding  
 42103 Public hearing on proposed budget; requirements for content of proposed budget  
 42122–42129 Budget requirements  
 42130–42134 Financial certifications  
 42140–42141 Disclosure of fiscal obligations  
 42238–42251 Apportionments to districts, especially:  
 42238.01–42238.07 Local control funding formula  
 42602 Use of unbudgeted funds  
 42610 Appropriation of excess funds and limitation thereon  
 45253 Annual budget of personnel commission  
 45254 First year budget of personnel commission  
 52060–52077 Local Control and Accountability Plan

GOVERNMENT CODE

7900–7914 Appropriations limit

CODE OF REGULATIONS, TITLE 5

15060 Standardized account code structure  
 15440–15451 Criteria and Standards for school district budgets  
 15494–15496 Local Control Funding Formula, expenditures

**Management Resources:**CALIFORNIA DEPARTMENT OF EDUCATION PUBLICATIONS

California School Accounting Manual

New Requirements for Reporting Fund Balance in Governmental Funds, January 7, 2011

FISCAL CRISIS AND MANAGEMENT ASSISTANCE TEAM PUBLICATIONS

Fiscal Oversight Guide for AB 1200, AB 2756 and Subsequent Related Legislation, September 2006

GOVERNMENT FINANCE OFFICERS ASSOCIATION

Best Practice: Appropriate Level of Unrestricted Fund Balance in the General Fund, 2009

GOVERNMENTAL ACCOUNTING STANDARDS BOARD STATEMENTS

Statement 75, Accounting and Financial Reporting by Employers for Post-employment Benefits Other Than Pensions, June 2015

Statement 54, Fund Balance Reporting and Governmental Fund Type Definitions, March 2009

WEBSITES

California School Boards Association: [www.csba.org](http://www.csba.org)

Association of California School Administrators: [www.acsa.org](http://www.acsa.org)

California Department of Education, Finance and Grants: [www.cde.ca.gov/fg](http://www.cde.ca.gov/fg)

California Department of Finance: [www.dof.ca.gov](http://www.dof.ca.gov)

Fiscal Crisis and Management Assistance Team: [www.fcmat.org](http://www.fcmat.org)

**BUDGET (cont.)**

Government Finance Officers Association: [www.gfoa.org](http://www.gfoa.org)  
Governmental Accounting Standards Board: [www.gasb.org](http://www.gasb.org)  
School Services of California, Inc.: [www.sscal.com](http://www.sscal.com)

**Chino Valley Unified School District**

Policy Adopted: November 16, 1995

Revised: June 3, 1999

Revised: September 4, 2008

Revised: April 2, 2009

Revised: June 30, 2011

REVISED:

**BUDGET**

~~The District budget shall be prepared annually from the best possible estimates that individual schools and district administrative staff can provide. Appropriate consolidation shall occur as the budget progresses through the various levels of review.~~

~~The District budget shall be developed in accordance with standards and criteria for fiscal accountability adopted by the State Board of Education. (Education Code 33129)~~

**Initial Budget Adoption PUBLIC HEARING**

~~On or before July 1 of each year, the Board shall adopt a budget which adheres to the State's Standardized Account Code Structure (SACS) as prescribed by the Superintendent of Public Instruction (SPI). (Education Code 42126, 42127)~~

~~Before adopting the district budget for the subsequent fiscal year, the Board shall hold a public hearing. The agenda for this THE PUBLIC hearing ON THE DISTRICT BUDGET shall be posted at least 72 hours before the hearing and shall indicate the location where the budget may be inspected. The proposed budget shall be available for public inspection at least three working days before this hearing. (Education Code 42103, 42127) The budget and supporting data shall be maintained and made available for public review.~~

~~Any District resident may appear at the public hearing and speak to the proposed budget or any item in on the budget. The hearing may conclude when all residents who so desire have had the opportunity to be heard. (Education Code 42103) Sufficient time shall be allowed so that the revised budget can be adopted by July 1.~~

~~The Superintendent or designee shall NOTIFY file the adopted budget with the County Superintendent OF SCHOOLS OF THE LOCATION, DATES, AND TIMES AT WHICH THE PROPOSED BUDGET MAY BE INSPECTED, AS WELL AS THE LOCATION, DATE, AND TIME OF THE PUBLIC HEARING, IN SUFFICIENT TIME FOR THE COUNTY SUPERINTENDENT TO PUBLISH SUCH INFORMATION IN A NEWSPAPER OF GENERAL CIRCULATION AT LEAST 10 DAYS BUT NOT MORE THAN 45 DAYS BEFORE THE HEARING AS REQUIRED BY EDUCATION CODE 42103. no later than five days after adoption or by July 1, whichever occurs first. The budget and supporting data shall be maintained and made available for public review.~~

~~WHENEVER THE PROPOSED DISTRICT BUDGET INCLUDES A COMBINED ASSIGNED AND UNASSIGNED ENDING FUND BALANCE THAT EXCEEDS THE MINIMUM RECOMMENDED RESERVE FOR ECONOMIC UNCERTAINTIES ADOPTED BY THE STATE BOARD OF EDUCATION, THE DISTRICT SHALL PROVIDE, FOR EACH FISCAL YEAR INCLUDED IN THE BUDGET, THE FOLLOWING INFORMATION FOR PUBLIC REVIEW AND DISCUSSION AT THE PUBLIC HEARING: (Education Code 42127; 5 CCR 15450)~~

**BUDGET (cont.)**

1. THE MINIMUM RECOMMENDED RESERVE FOR ECONOMIC UNCERTAINTIES
2. THE COMBINED ASSIGNED AND UNASSIGNED ENDING FUND BALANCES THAT ARE IN EXCESS OF THE MINIMUM RECOMMENDED RESERVE
3. A STATEMENT OF REASONS SUBSTANTIATING THE NEED FOR THE COMBINED ASSIGNED AND UNASSIGNED ENDING BALANCES THAT ARE IN EXCESS OF THE MINIMUM RECOMMENDED RESERVE

DURING THE HEARING, ANY DISTRICT RESIDENT MAY SPEAK TO THE PROPOSED BUDGET OR TO ANY ITEM IN THE BUDGET. THE HEARING MAY CONCLUDE WHEN ALL RESIDENTS WHO HAVE REQUESTED TO BE HEARD HAVE HAD THE OPPORTUNITY TO SPEAK. (Education Code 42103)

(cf. 9323 – Meeting Conduct)

**Revised Budget REVIEW COMMITTEE FOR DISAPPROVED BUDGETS**

~~No later than 45 days after the Governor signs the annual Budget Act, the Superintendent or designee shall make available for public review any revisions in budgeted revenues and expenditures which are consequently necessary.~~

~~If the County Superintendent disapproves the District's budget, the Board shall review and respond to his/her recommendations at a public meeting on or before September 8. the response shall include any revisions to the adopted budget and any other proposed actions to be taken as a result of those recommendations. (Education Code 42127)~~

~~(cf. 9320 – Meetings and Notices)~~

~~(cf. 9323 – Meeting Conduct)~~

IF THE DISTRICT'S BUDGET IS DISAPPROVED BY THE COUNTY SUPERINTENDENT FOR ANY REASON OTHER THAN HIS/HER DISAPPROVAL OF THE DISTRICT'S LOCAL CONTROL AND ACCOUNTABILITY PLAN (LCAP) OR ANNUAL UPDATE TO THE LCAP, THE BUDGET SHALL BE REVIEWED BY A BUDGET REVIEW COMMITTEE, UNLESS THE BOARD AND COUNTY SUPERINTENDENT AGREE TO WAIVE THE REQUIREMENT AND THE CALIFORNIA DEPARTMENT OF EDUCATION ACCEPTS THE WAIVER. (Education Code 42127)

This committee shall consist of either: (Education Code 42127.1, 42127.2)

1. THREE PERSONS SELECTED BY THE BOARD FROM A LIST OF CANDIDATES PROVIDED BY THE SUPERINTENDENT OF PUBLIC INSTRUCTION (SPI), WHO SHALL BE SELECTED WITHIN FIVE WORKING DAYS AFTER RECEIVING THE LIST OF CANDIDATES
2. A REGIONAL REVIEW COMMITTEE CONVENED BY THE COUNTY SUPERINTENDENT WITH THE APPROVAL OF THE BOARD

**BUDGET (cont.)**

IF THE BUDGET REVIEW COMMITTEE RECOMMENDS DISAPPROVAL OF THE DISTRICT BUDGET, THE BOARD MAY SUBMIT A RESPONSE TO THE SPI NO LATER THAN FIVE WORKING DAYS AFTER RECEIPT OF THE COMMITTEE'S REPORT. THE RESPONSE MAY INCLUDE ANY REVISIONS TO THE ADOPTED FINAL BUDGET AND ANY OTHER PROPOSED ACTIONS TO BE TAKEN AS A RESULT OF THE COMMITTEE'S RECOMMENDATIONS. (Education Code 42127.3)

IF THE SPI DISAPPROVES THE DISTRICT BUDGET AFTER REVIEWING THE COMMITTEE'S REPORT AND THE DISTRICT'S RESPONSE, THE BOARD SHALL CONSULT WITH THE COUNTY SUPERINTENDENT AS HE/SHE DEVELOPS AND ADOPTS, BY DECEMBER 31, A FISCAL PLAN AND BUDGET THAT WILL ALLOW THE DISTRICT TO MEET ITS FINANCIAL OBLIGATIONS. FOR THE CURRENT FISCAL YEAR, THE DISTRICT SHALL OPERATE IN ACCORDANCE WITH THE BUDGET ADOPTED BY THE COUNTY SUPERINTENDENT. (Education Code 42127.3)

UNTIL THE DISTRICT RECEIVES APPROVAL OF ITS BUDGET, IT SHALL CONTINUE TO OPERATE EITHER ON THE BASIS OF THE PRIOR YEAR'S BUDGET OR ON THE BASIS OF THE CURRENT YEAR'S UNAPPROVED BUDGET AS ADOPTED AND REVISED BY THE BOARD, WHICHEVER BUDGET CONTAINS A LOWER TOTAL SPENDING AUTHORITY. (Education Code 42127.4)

**Budget Advisory Committee**

Membership of the district's budget advisory committee may include representatives of each of the following groups:

1. Board of Education members, provided that less than a majority of the Board serves on the committee

(cf. 9140 – Board Representatives)

2. District and school site administrators
3. Representatives of bargaining units
4. Certificated and/or classified staff
5. Parents/guardians
6. Representatives of the business community and/or other community members
7. Students

(cf. 1220 – Citizen Advisory Committees)

(cf. 2230 – Representative and Deliberative Groups)

(cf. 9130 – Board Committees)

The committee's duties may include, but not necessarily be limited to:

1. Making recommendations regarding budget priorities
2. Recommending cost reduction strategies, such as identifying services that may be reduced, made more efficient, or discontinued

**BUDGET (cont.)**

3. Reviewing the clarity and effectiveness of budget documents and communications
4. Presenting progress reports on the committee's work and a final report of recommendations to the superintendent or designee and to the Board

The specific duties of the committee shall be clearly defined and presented to each member in writing, along with any background information necessary for the successful completion of the committee's charges, the timelines for reporting the committee's progress, and timelines for completion of each task.

**Chino Valley Unified School District**

Regulation Approved: November 16, 1995

Revised: June 3, 1999

Revised: August 21, 2008

Revised: March 5, 2009

REVISED:



**Chino Valley Unified School District**

**Our Motto:**

Student Achievement • Safe Schools • Positive School Climate  
Humility • Civility • Service

**DATE:** June 28, 2018

**TO:** Members, Board of Education

**FROM:** Wayne M. Joseph, Superintendent

**PREPARED BY:** Grace Park, Ed.D., Assistant Superintendent, Curriculum, Instruction, Innovation, and Support  
Tracy Freed, Ed.D., Director Assessment and Instructional Technology  
Julian Rodriguez, Ed.D., Director, Secondary Curriculum and Instruction

**SUBJECT: REVISION OF BOARD POLICY 5127 STUDENTS – GRADUATION CEREMONIES AND ACTIVITIES**

=====

**BACKGROUND**

Board policies, administrative regulations, and bylaws of the Board are routinely developed and revised as a result of changes in law, mandates, federal regulations, and current practice. Board Policy 5127 Students – Graduation Ceremonies and Activities is being revised to delete the California High School Exit Examination (CAHSEE) as a condition for high school graduation, and adjust the junior high school grading period to reflect current practice.

New language is provided in UPPER CASE while old language to be deleted is ~~lined through~~.

Consideration of this item supports the goals identified within the District's Strategic Plan.

**RECOMMENDATION**

It is recommended the Board of Education receive for information the revision of Board Policy 5127 Students – Graduation Ceremonies and Activities.

**FISCAL IMPACT**

None.

WMJ:GP:TF:JR:rtr

## **GRADUATION CEREMONIES AND ACTIVITIES**

### **Diploma**

High school graduation ceremonies shall be held to recognize those students who have earned a diploma by successfully completing the required course of study, passing any required assessments, and maintained a cumulative Grade Point Average (GPA) of 2.0, and have thereby earned the right to receive a diploma. The Board of Education believes that these students deserve the privilege of a public celebration that recognizes the significance of their achievement and encourages them to continue the pursuit of learning throughout their lives.

(cf. 6011 - Academic Standards)

(cf. 6143 - Courses of Study)

(cf. 6146.1 - High School Graduation Requirements)

(cf. 6146.4 - Differential Graduation and Competency Standards for Students with Disabilities)

At the discretion of the Superintendent or designee, a student who will complete graduation requirements during the summer may participate in graduation exercises without receiving his/her diploma. When the requirements have been satisfied, a diploma shall be sent to the student.

High school students who have passed ~~the California High School Proficiency Examination~~ or the General Educational Development Test must also meet District graduation requirements in order to participate in graduation ceremonies.

(cf. 6146.2 - Certificate of Proficiency/High School Equivalency)

The school or District shall not direct invocations, prayer, or benedictions at graduation ceremonies.

(cf. 1330 - Use of School Facilities)

(cf. 5145.2 - Freedom of Speech/Expression)

### **Honors and Awards**

To honor superior academic achievement, graduation ceremonies shall include recognition of valedictorian(s) and salutatorian(s). Valedictorian(s) and salutatorian(s) shall be selected based on established criteria and procedures that use multiple measures of academic performance.

(cf. 5121 - Grades/Evaluation of Student Achievement)

The Superintendent or designees shall identify other school-sponsored awards which may be given during graduation exercises. A separate awards program may be held to recognize graduating students receiving other school and nonschool awards.

**GRADUATION CEREMONIES AND ACTIVITIES (cont.)**

(cf. 5126 - Awards for Achievement)

**Honorary Diploma**

Students with special needs who have differential standards for graduation delineated in their IEP and who meet those standards shall receive an Honorary Diploma and shall be allowed to participate in graduation ceremonies and senior activities.

**Certificate of Credit**

Students who complete the course requirements, but who have failed to meet ~~one of the additional~~ 2.0 GPA requirements for a diploma shall receive a Certificate of Credit instead of a Diploma and shall be allowed to participate in graduation ceremonies pursuant to Board Policy 5127 Graduation Ceremonies and Activities.

~~Students who are eligible for a Certificate of Credit are those who meet all course requirements but have failed to meet one of the following criteria:~~

~~Achieve a GPA of 2.0; or~~

~~Pass both sections of the California High School Exit Examination (CAHSEE).~~

Students who have not completed all course requirements are not eligible for a certificate and shall not participate in graduation ceremonies. Students who have failed to meet both of the additional criteria listed above are not eligible for a certificate and shall not participate in graduation ceremonies.

(cf. 3260 - Fees and Charges)

(cf. 6143 - Courses of Study)

(cf. 6146.1 - High School Graduation Requirements/Standards of Proficiency)

(cf. 6146.4 - Differential Graduation and Competency Standards for Individuals with Exceptional Needs)

**Conduct at Graduation Ceremonies**

Any student participating in a graduation ceremony shall comply with District policies and regulations pertaining to student conduct.

(cf. 5131 - Conduct)

The Superintendent or designee may require graduating students to wear ceremonial attire, such as cap and gown, at the ceremony.

However, any graduating student who has completed basic training and is an active member of any branch of the United States Armed Forces, may, at his/her option, wear his/her military dress uniform at the ceremony. (Education Code 65183.3)

**GRADUATION CEREMONIES AND ACTIVITIES (cont.)****Disciplinary Considerations**

In order to encourage high standards of student conduct and behavior, the principal may deny the privilege of participating in graduation ceremonies and/or activities in accordance with school rules. Prior to denial of the privilege, the student, and where practicable his/her parent/guardian, shall be made aware of the grounds for such denial and shall be given an opportunity to respond. If a privilege is to be denied, the student and parent/guardian shall receive written notice of the denied privilege and the means whereby he/she may appeal the decision.

(cf. 5125.2 - Withholding Grades, Diploma or Transcripts)

(cf. 5144 - Discipline)

(cf. 6161.2 - Damaged or Lost Instructional Materials)

**Foreign Exchange Students**

Foreign exchange students may receive honorary diplomas during the graduation ceremony. (Education Code 51225.5)

**Elementary/Junior High School Promotion Exercises**

At the junior high school level, students must have a 2.0 GPA in their final ~~semester~~ TRIMESTER and no more than two (2) "unsatisfactory" (U) citizenship grades in order to participate in promotion exercises.

**Legal Reference:****EDUCATION CODE 10**

35183.3 Graduation ceremonies; military dress uniforms

38119 Lease of personal property; caps and gowns

48904 Liability of Parent or Guardian; Withholding of Grades, Diplomas, Transcripts

51225.5 Honorary Diplomas; Foreign Exchange Students

51410-51412 Diplomas

**COURT DECISIONS**

Cole v. Oroville Union High School District, (2000, 9<sup>th</sup> Cir.) 228 F.3d 1092

Santa Fe Independent school district v. doe, (2000) 530 U.S. 290

Lee V. Weisman, (1992) 505 U.S. 577

Sands v. Morongo Unified School District (1991) 53 Cal. 3d 863

Lemon v. Kurtzman (1971) 403 U.S. 602

**Management Resources:****WEBSITES**

California Department of Education, High School: [www.cde.ca.gov/ci/gs/hsl](http://www.cde.ca.gov/ci/gs/hsl)

**GRADUATION CEREMONIES AND ACTIVITIES (cont.)**

**Chino Valley Unified School District**

Policy adopted: January 23, 1997

Revised: March 7, 2002

Revised: June 5, 2003

Revised: May 1, 2008

Revised: May 20, 2010

REVISED:

**Chino Valley Unified School District**

**Our Motto:**

Student Achievement • Safe Schools • Positive School Climate  
Humility • Civility • Service

**DATE:** June 28, 2018

**TO:** Members, Board of Education

**FROM:** Wayne M. Joseph, Superintendent

**PREPARED BY:** Grace Park, Ed.D., Assistant Superintendent, Curriculum, Instruction, Innovation, and Support  
Preston Carr, Ed.D., Director, Alternative Education  
Julian Rodriguez, Ed.D., Director, Secondary Curriculum and Instruction

**SUBJECT: REVISION OF ADMINISTRATIVE REGULATION 6146.11  
INSTRUCTION – ALTERNATIVE CREDITS TOWARD GRADUATION**

=====

**BACKGROUND**

Board policies, administrative regulations, and bylaws of the Board are routinely developed and revised as a result of changes in law, mandates, federal regulations, and current practice. Administrative Regulation 6146.11 Instruction – Alternative Credits Toward Graduation is being updated to replace California Standards Tests with California Assessment of student Performance and Progress (CAASPP) that was established January 1, 2014.

New language is provided in UPPER CASE while old language to be deleted is lined through.

Consideration of this item supports the goals identified within the District's Strategic Plan.

**RECOMMENDATION**

It is recommended the Board of Education receive for information the revision of Administrative Regulation 6146.11 Instruction - Alternative Credits Toward Graduation.

**FISCAL IMPACT**

None.

WMJ:GP:PC:JR:rtr

## **ALTERNATIVE CREDITS TOWARD GRADUATION**

### **Definitions**

A semester period is one period of 40 to 60 minutes of instructional time per week throughout one semester of at least 17 weeks, or a minimum of 12 clock hours of instructional time provided during the academic year or in summer school. While the content to be covered is planned within these time frames, a student may be granted one semester period of credit even though the student spends less than the aforementioned amount of time in completing the necessary work. (5 CCR 1600)

### **Juvenile Court School**

The District shall accept for credit any coursework satisfactorily completed by students while detained in a juvenile court school or county or state-operated institution. District students who successfully complete district graduation requirements while so detained shall receive a diploma from the school they last attended. (Education Code 48645.5)

### **Practical Demonstration of Skills and Competencies**

At the discretion of the Superintendent, credit may be granted to students transferring from a school outside the state or country, or from a non accredited private, alterative, charter, or home school through practical demonstration of skills and competencies. This option is available only when previous successfully competed course work is similar to, but does not match, courses required for graduation and when the student would otherwise be unable to earn sufficient credits to graduate with his/her class.

The examination shall be comprehensive and cover all course objectives. Successful completion of the examination shall be at a level which indicated mastery of the content and/or reasonable chance for success in the next higher course.

Students in grades K-8 who transfer into the District without proof of having met the grade level proficiency standards in reading, mathematics, and writing must take the appropriate district tests of these basic skills to facilitate proper placement.

The principal at the enrolling school shall be responsible for determining which of the students credits are equivalent to district requirements.

The process for granting credit by examination at grades 9-12 shall include, but not be limited to, the following:

The student transcript is evaluated and credit given for courses which match district academic standards, time requirements, and graduation requirements.

**ALTERNATIVE CREDITS TOWARD GRADUATION** (cont.)

Credit may be given where an examination of the student's portfolio of work, papers, completed project, graded tests or other documents demonstrate a level of skill and knowledge which match district academic standards, time requirements, and graduation requirements.

The principal determines that the student cannot earn sufficient credits in the District to graduate with his/her appropriate class.

For courses that are similar, an opportunity may be offered for the student to demonstrate skills by his/her performance on appropriate examinations, comprehensive final examinations, and/or other culminating examinations which demonstrate mastery of the course content.

The student and their parents are informed of the option to earn credits through examination and the requirements.

The student may be provided with the textbook for the course and given a period of two weeks to review the material.

The examination will be administered at a time and location to be determined by the school.

Within 10 workdays of the administration of the examination, the parent and student will be notified of the results of the examination.

The course grade shall be determined by the score earned on the examination.

The parents, student, and counselor will meet to develop a plan for graduation for the student.

Once a student has been placed in a course, the teacher shall verify that the student has achieved a level of preparation consistent with his/her placement in that class.

If a student's parent/guardian disagrees with the school site staff's judgment on grade-level placement, course placement and/or equivalency of academic credit, the parent/guardian may appeal to the Superintendent or designee. It is the parent's/guardian's responsibility to provide evidence of equivalency of course content alignment to California Academic Content Standards.



## **ALTERNATIVE CREDITS TOWARD GRADUATION (cont.)**

Within 10 working days of notification of placement or credit determination, the parent/guardian may request, in writing, a conference with the Superintendent or designee to review the school site staff's decision.

The Superintendent or designee shall schedule a conference within 10 working days of the parent/guardian's request. This meeting may include the principal or designee, representatives of the school's certificated staff, and the student's parents/guardian. It shall be the parent/guardian's responsibility to present evidence that the facts do not support the school staff's decision on the student's placement and/or transferability of prior credits.

The Superintendent or designee's decision shall be final.

### **Supervised Work Experience Education**

A student may be granted up to forty (40) total units of credit for work experience education. No more than ten (10) units can be earned in any one semester, with a maximum of twenty (20) units in two semesters.

To receive credit, the student must satisfy eligibility requirements and receive at least the minimum period of instruction or counseling pursuant to Education Code 51760.3.

### **Career Technical Education Classes Offered in High Schools**

Credit shall be granted for career technical courses offered at the student's high school of attendance.

### **Courses Offered by Regional Occupational Centers or Programs**

A student shall be granted credit for courses offered by Regional Occupational Programs (ROP) or centers when appropriately enrolled.

The student must satisfy all eligibility requirements and receive at least the minimum services specified in Board Policy and Administrative Regulations 6178.

### **Independent Study**

A qualifying student may receive credit for courses taken through the District's independent study or home-based independent study programs as specified in Board Policy and Administrative Regulations 6158.

**ALTERNATIVE CREDITS TOWARD GRADUATION** (cont.)**Credit Earned at a Postsecondary Institution**

At his/her discretion, the Superintendent or designee may grant credit toward high school graduation for course work successfully completed at a junior college or state college, provided that:

1. The principal of a school recommends a pupil for community college summer session only if that pupil meets all of the following criteria:
  - a. Demonstrates adequate preparation in the discipline to be studied.
  - b. Exhausts all opportunities to enroll in an equivalent course, if any, at his or her school of attendance. (Education Code 48800 D)
  - c. Secures the signature of the principal authorizing enrollment.
2. The student or parent/guardian applies in writing for the credit. (Code of Regulations, Title 5, Section 1630) and submits written evidence from the college showing that the course meets state and district standards.
3. The course subject is included in the high school course of study. (Title 5, Section 1630)
4. Upon completion of the course the student or parent/guardian submits a sealed official transcript showing that the student successfully completed the course.
5. At the student's request, the course is not being applied for credit toward college graduation. (Title 5, Section 1630)
6. A pupil shall receive credit for community college courses that he or she completes at the level determined appropriate by the school district and community college district governing boards. (Education Code 48800 C)
7. The student receives the same letter grade for the high school credit as is granted by the college.

**Private Instruction**

A student who is regularly enrolled and in attendance at a high school shall receive credit toward high school graduation for private instruction under the following conditions:

**ALTERNATIVE CREDITS TOWARD GRADUATION** (cont.)

At his/her discretion, the Superintendent or designee may grant credit toward high school graduation for private instruction, provided that:

1. The instruction entails fields and subjects included in the school's courses of study and curricula. (5 CCR 1631)
2. The student demonstrates his/her capabilities at the beginning and at the end of the period of private instruction by examination(s) given under the school's supervision, thereby showing that he/she has made satisfactory progress in learning satisfactory to the school. (5 CCR 1631)
3. The Superintendent or designee has approved the curriculum and final evaluation instrument used in the private instruction.
4. Credit earned for private instruction while the student attends district schools in grades nine through 12 is limited to 10 credits for any year.

**Correspondence Instruction**

Prior to registering for a correspondence course, the student or his/her parent/guardian shall obtain verification from the Superintendent or designee that the course is essentially equivalent to the high school curriculum and meets District graduation requirements. The number of semester credits assigned to the course shall be determined before the student begins coursework.

The District shall grant credit toward graduation for correspondence instruction if all of the following conditions are met: (Education Code 51740, 51741; 5 CCR 1633)

1. The correspondence instruction is provided by the University of California, or other university or college in California accredited for teacher training, in subjects included within or related to the student's course of study.
2. The student is, for good reason, unable to take the course of study offered in the school.
3. The Superintendent or designee determines the number of semester periods to be credited for successful completion of a particular correspondence course.
4. No more than 40 total semester periods of correspondence instruction are credited to a student towards graduation.

**ALTERNATIVE CREDITS TOWARD GRADUATION** (cont.)**Military Service and Training**

College credit toward graduation shall be granted for military service and training received while in the military service of the United States, within the maximum limits established in 5 CCR 1634. A person is eligible for this credit if he/she is either: (Education Code 51440; 5 CCR 1634)

1. A former member of the Armed Forces who is a California resident and who has received an honorable discharge
2. A member of the Armed Forces who is a California resident and was a California resident on the date he/she entered the Armed Forces

The Superintendent or designee shall keep a permanent record of the credit allowed for military service or training. (5 CCR 1634)

(cf. 5125 - Student Records)

**Coursework Completed at Institutions External to the School District**

The Superintendent or designee may, with evidence of prior approval grant credit toward high school graduation for coursework successfully completed in institutions external to the school district for the purposes of remediation, acceleration, or as a result of an impacted pupil schedule. However, all pupils are expected to complete core courses during the year they are to be tested on the California Standards Tests ASSESSMENT OF STUDENT PERFORMANCE AND PROGRESS (CAASPP).

Students are expected to take English, math, science, and social science courses that are tested on a district campus.

All coursework taken at institutions external to the district must meet California state content standards and Chino Valley Unified School District expectations for content, academic rigor and appropriate levels of academic performance. Students will be required to take end of course examinations in courses where the District has created such exams. Academic credit may be denied if students do not demonstrate adequate knowledge, skills, and competencies normally required of students taking similar courses in the District.

Before requesting approval of coursework at institutions external to the District, pupils must exhaust all opportunities to enroll in an equivalent course at their school of attendance.

A parent/guardian must request in writing that a pupil be allowed to complete a course in an institution external to the District for the purposes of remediation, acceleration or

**ALTERNATIVE CREDITS TOWARD GRADUATION** (cont.)

as a result of an impacted pupil schedule at the district high school the pupil normally attends.

The request will be approved or denied by the high school principal, or by the Director of Secondary Curriculum and Instruction in the case where the principal is on vacation or if there is a vacancy in the principal chair. Pre-approval by the principal is mandatory.

The parent/guardian, pupil and principal will sign a contract stating that the pupil will enroll in the next higher level course on their high school campus. The contract will be placed in the student CUM folder and noted in the District computer system.

Sealed official school transcripts must be delivered to the principal or principal designee upon completion of coursework completed at institutions external to the school district.

**Physical Education**

Physical education courses must be taken on a district campus. Physical Education is now monitored by the California Department of Education through the categorical program monitoring regulations as an area of accountability and compliance.

Credit toward the district's physical education requirements may be earned through participation in district interscholastic athletic programs carried on wholly or partially after regular school hours when such participation entails a comparable amount of time and physical activity, when instruction includes all standards for the District adopted physical education curriculum, and provided that a teacher credentialed to teach physical education supervises the participation and assigns the grade.

**Private Foreign Language Instruction**

The District shall grant credit for foreign language studies successfully completed in a private school and shall apply the credit toward meeting any foreign language requirement prescribed for grades 9-12, provided that all of the following conditions are met: (Education Code 51243-51245; 5 CCR 1632)

1. The courses are in languages designated in Education Code 51244.
2. The student is regularly enrolled or applying to the District in grades 9-12.
3. The student or his/her applies in writing for the credit, specifies the private school attended and the amount and level of credit requested and submit a transcript or other documents from the private school showing that the student successfully completed the course.

**ALTERNATIVE CREDITS TOWARD GRADUATION** (cont.)

4. The amount of credit sought equals at least one semester's work.
5. The principal or designee determines that the student's achievement is equivalent to that expected of a student of comparable ability taking the same or similar instruction in district schools. This determination shall be based upon the private school's report of a test developed by the private school in cooperation with the District or, if the private school is located outside the District, the principal or designee may use a test given by a public school or other evidence which he/she deems appropriate.

**Chino Valley Unified School District**

Regulation approved: August 21, 1997

Revised: February 16, 2006

Revised: January 24, 2008

Revised: March 3, 2011

REVISED: